



## IQS7222D GUI Setup Guide

The GUI setup guide introduces the development tools available for the product and guides the setup of certain key elements.

### Contents

<b>1</b>	<b>Introduction</b>	<b>2</b>
<b>2</b>	<b>Getting Started</b>	<b>4</b>
2.1	Step 1: GUI Software Installation . . . . .	4
2.2	Step 2: Launch GUI Software . . . . .	4
2.3	Step 3: Hardware Connections . . . . .	4
2.4	Step 4: PC Connection Verification . . . . .	5
2.5	Step 5: Initiate IQS7222D Communication (Streaming) . . . . .	6
2.6	Step 6: Acknowledge Reset and Streaming Mode . . . . .	7
2.7	Step 7: User Settings . . . . .	7
<b>3</b>	<b>IQS7222D Debug and Display Software Overview</b>	<b>9</b>
3.1	IQS7222D Streaming Data . . . . .	9
3.1.1	Bar Graph . . . . .	10
3.1.2	Scope View . . . . .	11
3.1.3	Slider . . . . .	12
3.2	Data Logging . . . . .	12
3.3	Export Device Configuration to H-File . . . . .	13
3.4	Import Preconfigured H-File . . . . .	13
3.5	Command Buttons . . . . .	14
3.5.1	Acknowledge Reset . . . . .	14
3.5.2	Soft Reset . . . . .	14
3.5.3	ATI All and Read . . . . .	14
3.5.4	Reseed . . . . .	14
3.6	Trackpad . . . . .	15
3.7	Events . . . . .	16
3.7.1	System Status . . . . .	16
3.7.2	Events . . . . .	16
<b>4</b>	<b>Reference Design</b>	<b>17</b>
4.1	IQS7222DEV01 . . . . .	17
4.1.1	General-Purpose Stamp Module . . . . .	17
4.2	IQS7222D Module in the EVO2 EV Kit . . . . .	18
4.2.1	Trackpad Module . . . . .	18



## 1 Introduction

This document provides an overview of the IQS7222D ProxFusion<sup>®</sup> device, the graphical user interface (GUI), and the IQS7222D evaluation (EV) kits. It aims to equip users with the knowledge needed for configuring, debugging, data logging, and header file export using the GUI software to address their unique applications.

The IQS7222DEV01 is a general-purpose stamp module that can be used for rapid prototyping and development. It can be connected to external sensing electrodes, allowing the user to experiment with their own sensor designs. See the IQS7222DEV01 reference schematic in Section 4.1

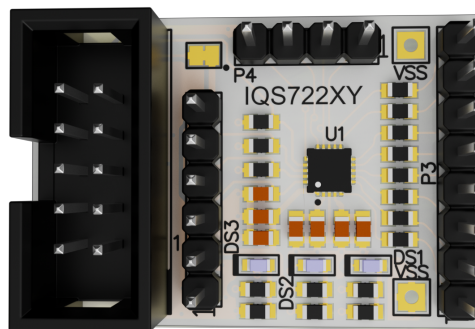

Figure 1.1: IQS7222DEV01 EV Kit

The IQS7222D module in the IQS7222DV02 EV kit showcases a 14 channel mutual / 8 channel self-capacitive touch and proximity controller with I<sup>2</sup>C communications interface. See the IQS7222D reference schematics in Section 4.2.

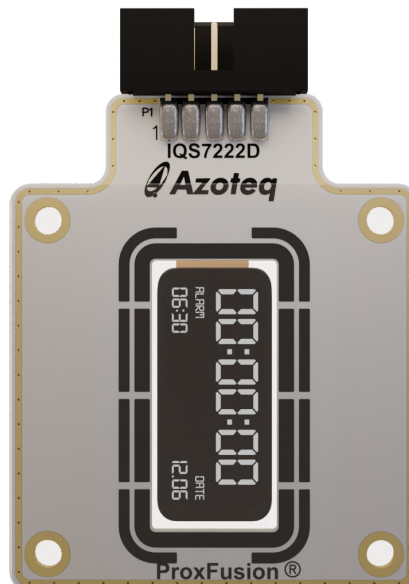

Figure 1.2: IQS7222DEV02 EV Kit

This user guide follows the procedure of configuring the IQS7222D device to perform sensing on the IQS7222D module in the EV02 EV kit.



The following application notes provide background information and design guidelines for the various sensing methods supported by the IQS7222D.

- > Azoteq Sensing Technologies: [AZD004](#)
- > Capacitive Sensing Design Guide: [AZD125](#)
- > Inductive Design Layout Guide: [AZD115](#)

For IC-specific information, operation, and memory map details, please refer to the [IQS7222D Datasheet](#).



## 2 Getting Started

This section describes the process of initial device and GUI set-up prior to application-specific tuning.

### 2.1 Step 1: GUI Software Installation

Download and install the Azoteq IQS7222D GUI PC Software from the Azoteq website under the [Software and Tools](#) page. Extract the downloaded zip file and follow the installation wizard procedure.

### 2.2 Step 2: Launch GUI Software

Launch the IQS7222D GUI software executable. The following window should appear:

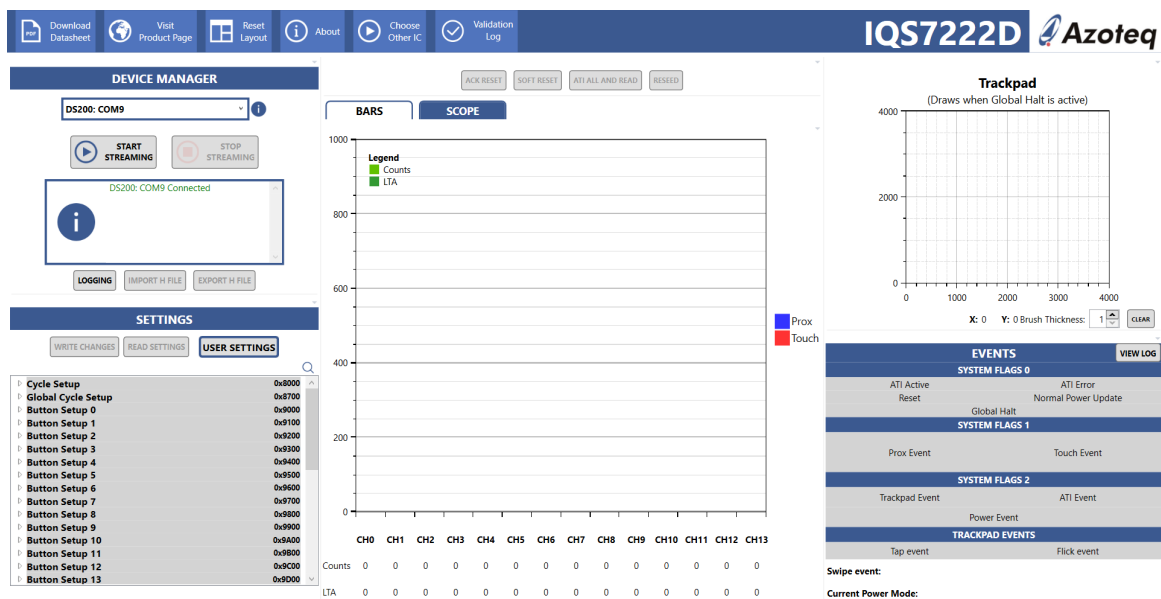

Figure 2.1: Main Window of the Azoteq IQS7222D GUI

### 2.3 Step 3: Hardware Connections

Connect the DS200 to your PC, using a standard type-C cable. The device under test (DUT), being either an IQS7222D EV kit or an application PCBA, can be interfaced with a suitable 10-to-10 pin ribbon cable connection (or application-specific connections), as shown in Figure 2.2 below.

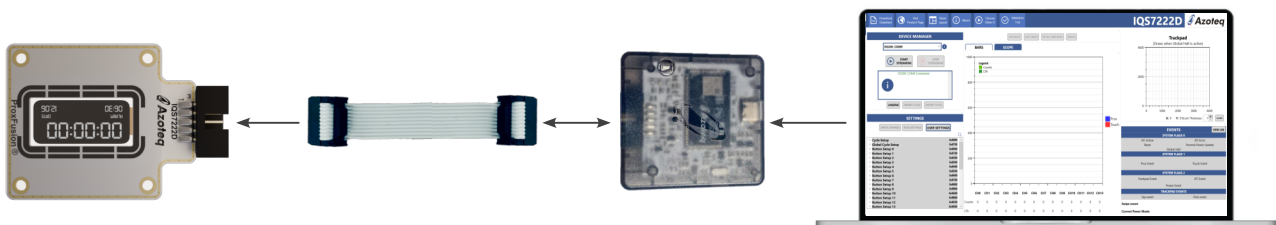

Figure 2.2: DS200 Connection for Streaming and Testing

**Note:** The CT210A can be used instead of the DS200, along with a standard USB-micro data cable and a suitable 20-to-10 pin ribbon cable connection, as shown in Figure 2.3 below.



Figure 2.3: CT210A Connection for Streaming and Testing

If a custom cable or hardware is used, please refer to Table 2.1 and Figure 2.4 for the required connections.

Table 2.1: DS200 Pin-out

IQS Pins	DS200 Pins
GND	Pin 1
VDD	Pin 3
SDA	Pin 7
SCL	Pin 9
RDY	Pin 10



Figure 2.4: DS200 Power, I<sup>2</sup>C and RDY Connections

## 2.4 Step 4: PC Connection Verification

After connecting the DS200 device to the computer, the GUI software will automatically install any necessary drivers. It will then verify the DS200 connection and firmware version, displaying a 'Device Connected' message in the configuration tool manager section, as shown in the red block in Figure 2.5.

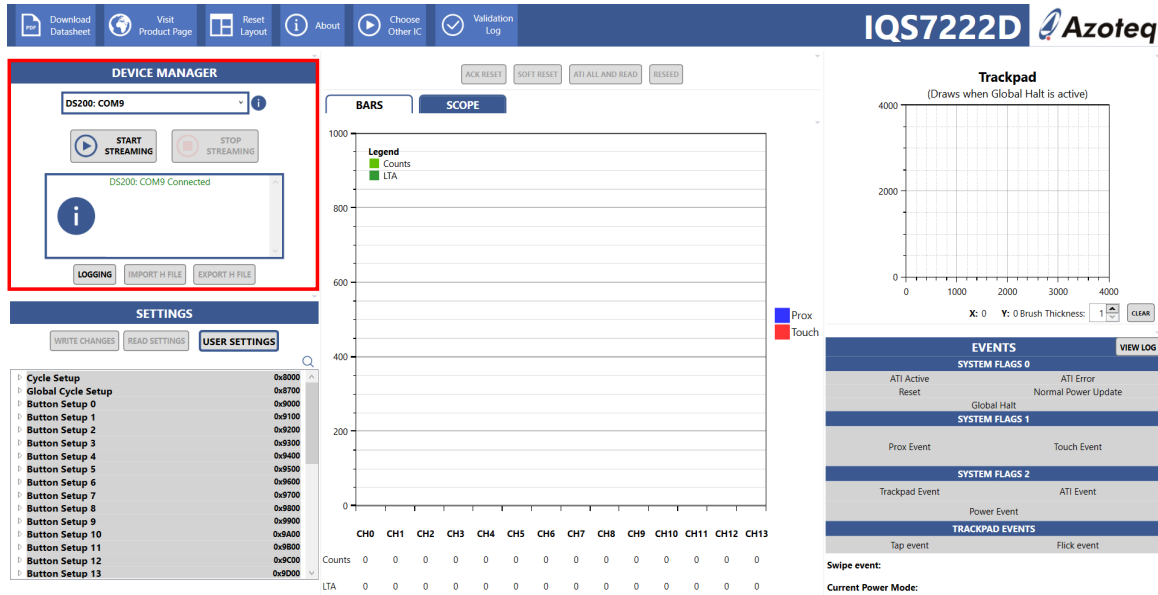

Figure 2.5: DS200 Recognition and Connection

**Note:** If the connected DS200 device firmware is out of date, an ‘Update available’ button should automatically appear next to the device enumeration. Click this button to launch the Azoteq firmware upgrade tool and update the firmware, as shown in Figure 2.6.

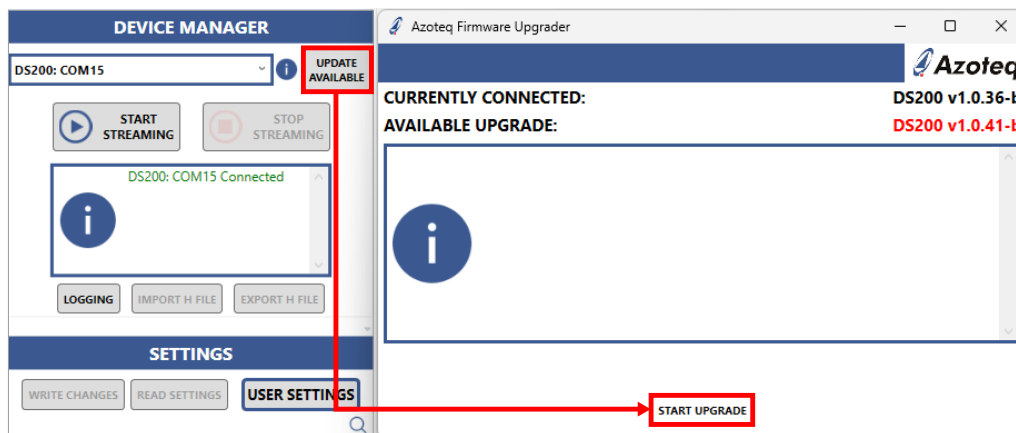

Figure 2.6: DS200 Firmware Upgrade

## 2.5 Step 5: Initiate IQS7222D Communication (Streaming)

Click on ‘Start Streaming’ to initiate communications with the IQS7222D. Additional messages will appear and will provide the following information:

- > Power status
- > I<sup>2</sup>C address
- > Device version information
- > Settings and streaming confirmations or errors, as applicable

Note that the IQS7222D product can be ordered with different I<sup>2</sup>C addresses. The GUI will automatically try each address until the device responds.

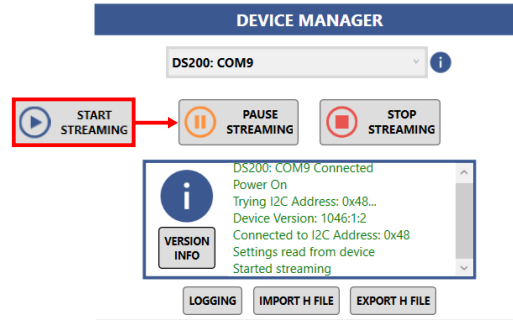

Figure 2.7: Message Dialogue Results from a Successful IQS7222D Connection

If an error is displayed, please ensure that the device is properly connected and that the IQS7222D’s product and version numbers were verified successfully.

## 2.6 Step 6: Acknowledge Reset and Streaming Mode

Click on the red text button ‘ACK Reset’ to clear the reset event flag. The ‘ACK Reset’ text should change colour to black, indicating successful reset acknowledgement.



Figure 2.8: ACK Reset Button

The IQS7222D starts in streaming mode, as shown in Figure 2.9. The default settings are *not* an appropriate baseline for a production application.



Figure 2.9: IQS7222D Streaming

## 2.7 Step 7: User Settings

Open the “User Settings” window, navigate through the menu to configure settings for the demo. Refer to Figure 2.10.



Settings

### Cycle Settings 0 - 3

**Cycle 0 - CH0 & CH7**

**PXS Mode:** Mutual Capacitance

**Cycle 0 Conversion Frequency Period:** 5 NaN MHz

**Tx Select**

CTx0  CTx1  CTx2  CTx3  CTx4  CTx5  CTx6  CTx7  CTx8

Ground Inactive Rx's  Dead Time Enable  VBias Enable  FOSC TX Frequency

**Cycle 1 - CH1 & CH8**

**PXS Mode:** Mutual Capacitance

**Cycle 1 Conversion Frequency Period:** 5 NaN MHz

**Tx Select**

CTx0  CTx1  CTx2  CTx3  CTx4  CTx5  CTx6  CTx7  CTx8

Ground Inactive Rx's  Dead Time Enable  VBias Enable  FOSC TX Frequency

**Cycle 2 - CH2 & CH9**

**PXS Mode:** Mutual Capacitance

**Cycle 2 Conversion Frequency Period:** 5 NaN MHz

**Tx Select**

CTx0  CTx1  CTx2  CTx3  CTx4  CTx5  CTx6  CTx7  CTx8

Ground Inactive Rx's  Dead Time Enable  VBias Enable  FOSC TX Frequency

**Cycle 3 - CH3 & CH10**

**PXS Mode:** Mutual Capacitance

**Cycle 3 Conversion Frequency Period:** 5 NaN MHz

**Tx Select**

CTx0  CTx1  CTx2  CTx3  CTx4  CTx5  CTx6  CTx7  CTx8

Ground Inactive Rx's  Dead Time Enable  VBias Enable  FOSC TX Frequency

**WRITE CHANGES** **READ SETTINGS**

No Changes To Write

Figure 2.10: User Setting Window



### 3 IQS7222D Debug and Display Software Overview

This section briefly explains the GUI elements such as the sensor graphs, device events, and commands, as well as some additional core functionality such as data logging and exporting of device settings.

#### 3.1 IQS7222D Streaming Data

The IQS7222D supports up to 14 ProxFusion® channels. The “counts” of each channel is a representation of the signal strength measured by the sensor.

The IQS7222D GUI displays the counts of each channel in the graph panel in the centre of the GUI. The default graph view is the bar graph, which plots the instantaneous counts of each channel.

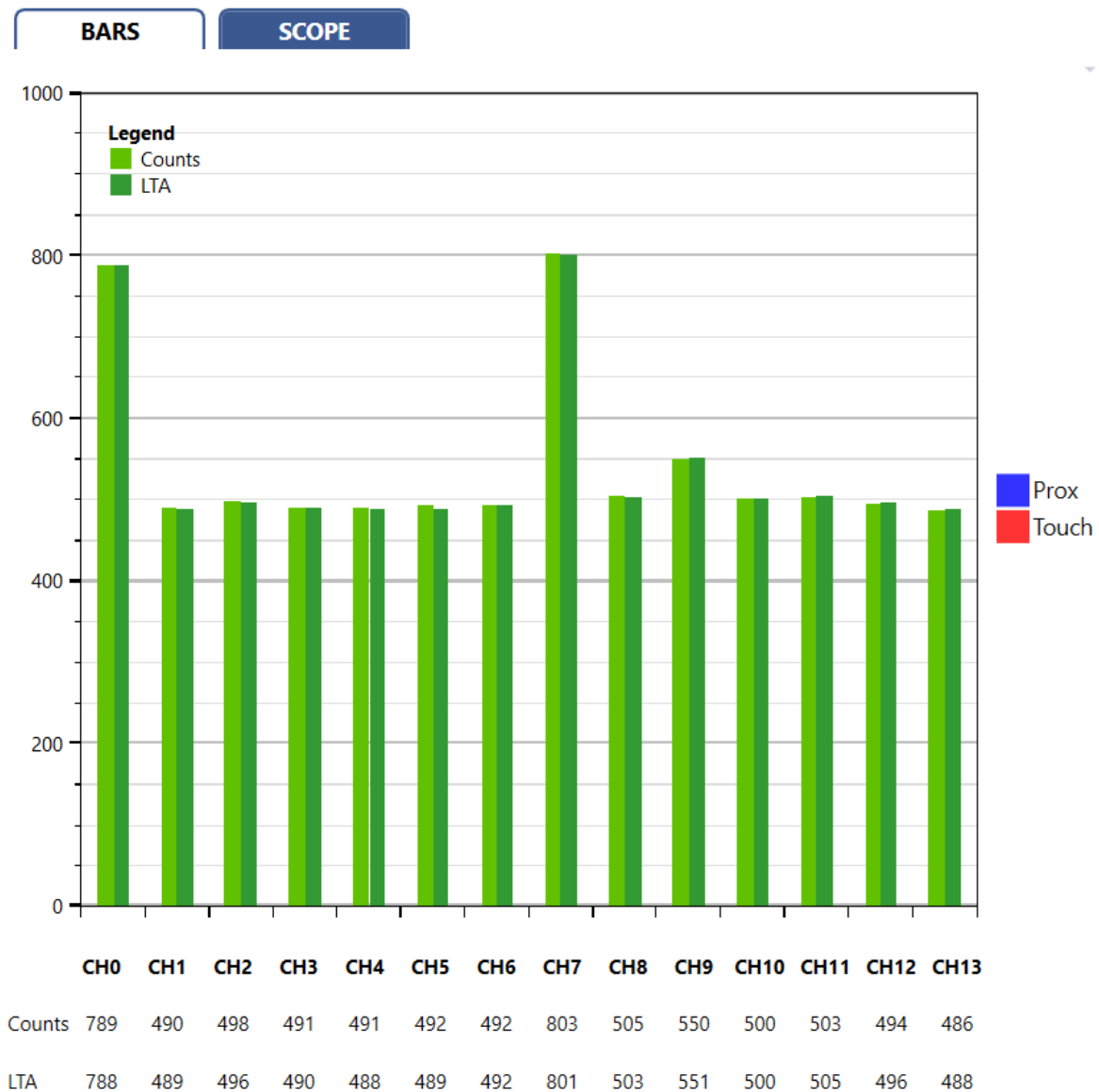

Figure 3.1: Streaming Graphs



The graph views can be manipulated with the following controls:

- > Scroll wheel to zoom in and out.
- > Hold and drag middle-mouse button to zoom to a bounding box.
- > Hold and drag right-mouse button to pan.
- > Double left-click to reset the graph view.

**Note:** All the signals recorded in the graphs and sliders are read directly from the IC. For more information regarding the register map, please consult the [IQS7222D datasheet](#).

### 3.1.1 Bar Graph

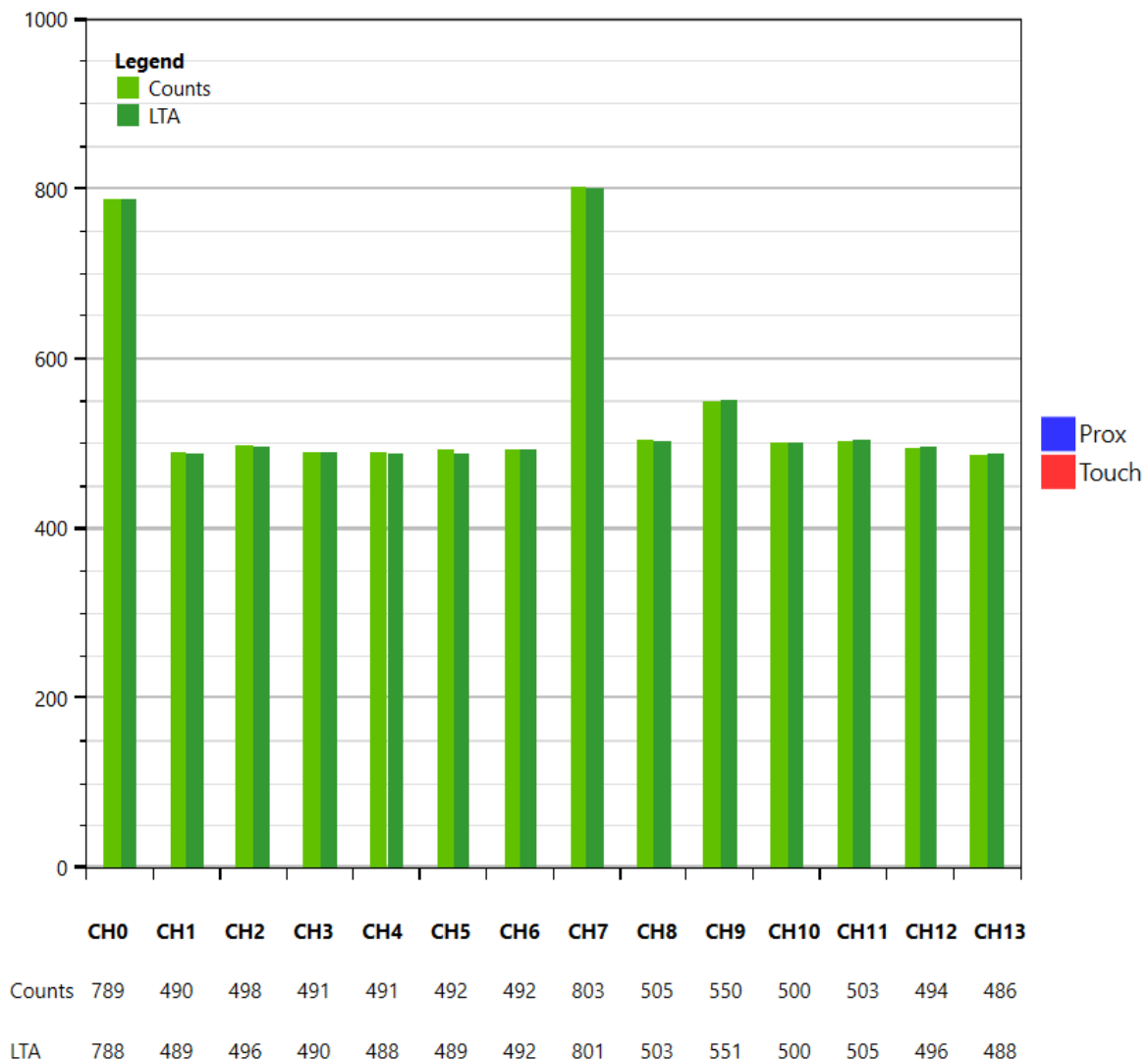

Figure 3.2: Bar Graph View of Channel Counts

For each ProxFusion<sup>®</sup> channel, the bar graph shows the counts of the capacitive/touch sensor. The **counts** value shows the raw measurement of the sensor, after filtering. The **LTA** is the Long Term Average of the counts signal. It tracks slow variations in the environment, and is used as a reference to detect movement; refer to [AZD004](#) for more details.



### 3.1.2 Scope View

The scope view plots the counts and LTAs of each ProxFusion® channel over time.

The data in the current view of the scope can be saved to a CSV file. To save the data, first click 'Pause Streaming'. Once paused, the button will say 'Restart Streaming', as shown in Figure 3.3.

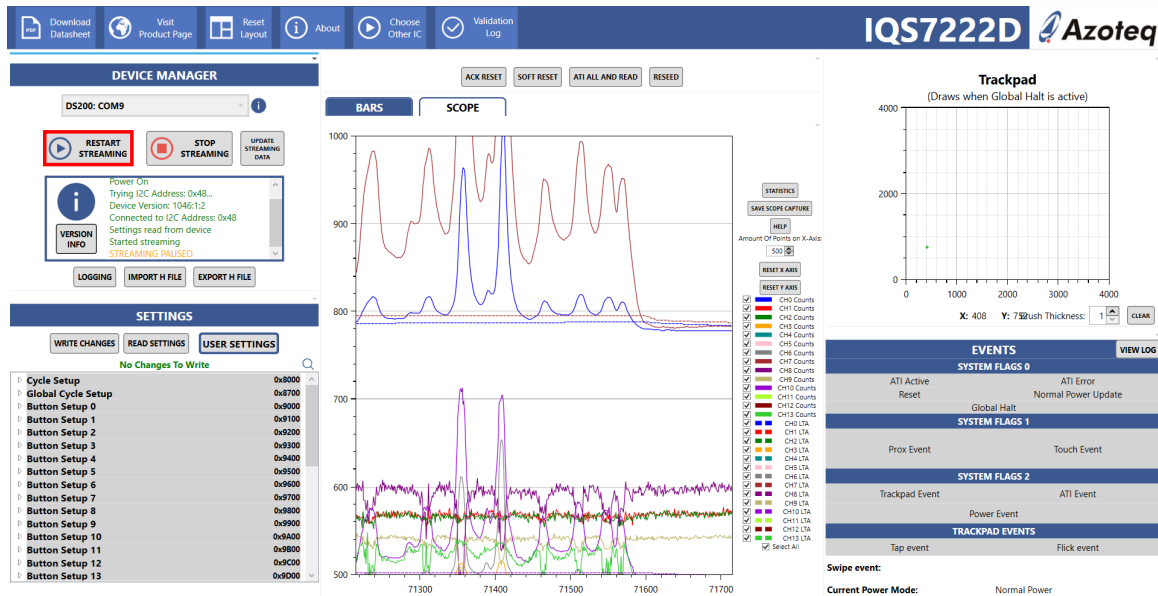

Figure 3.3: Pausing Streamed Data

Then click the 'Save Scope Capture' button that appears on the right of the scope view, as indicated with a red block in Figure 3.4.

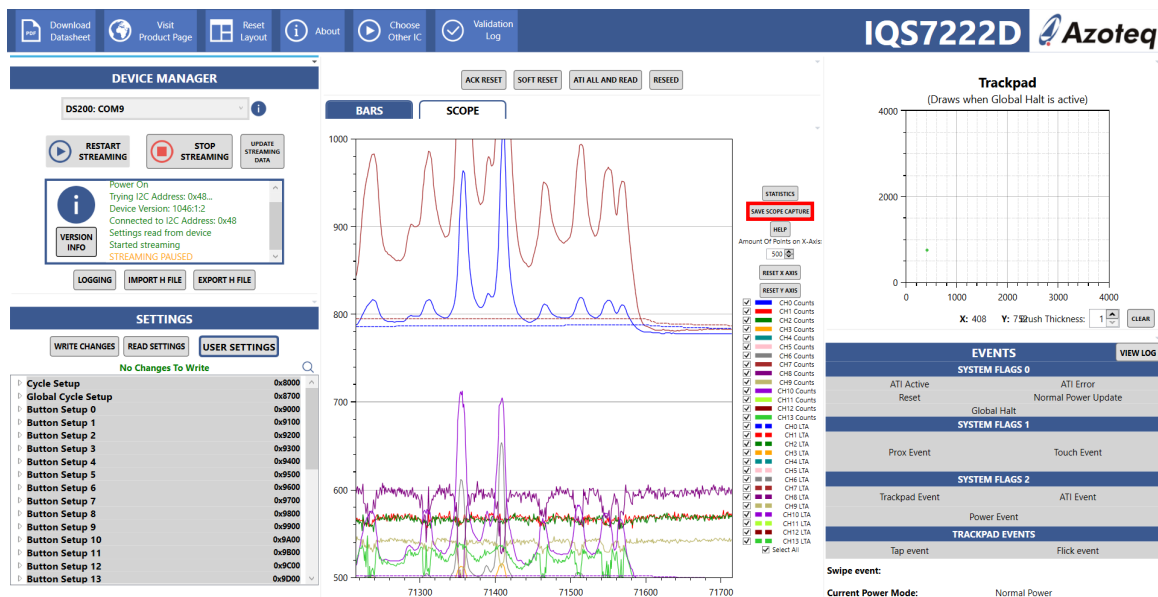

Figure 3.4: Saving Streamed Data

The following window will pop up and prompt the user to select which part of the data should be saved. Select the "Save to CSV" button to save the streamed data.

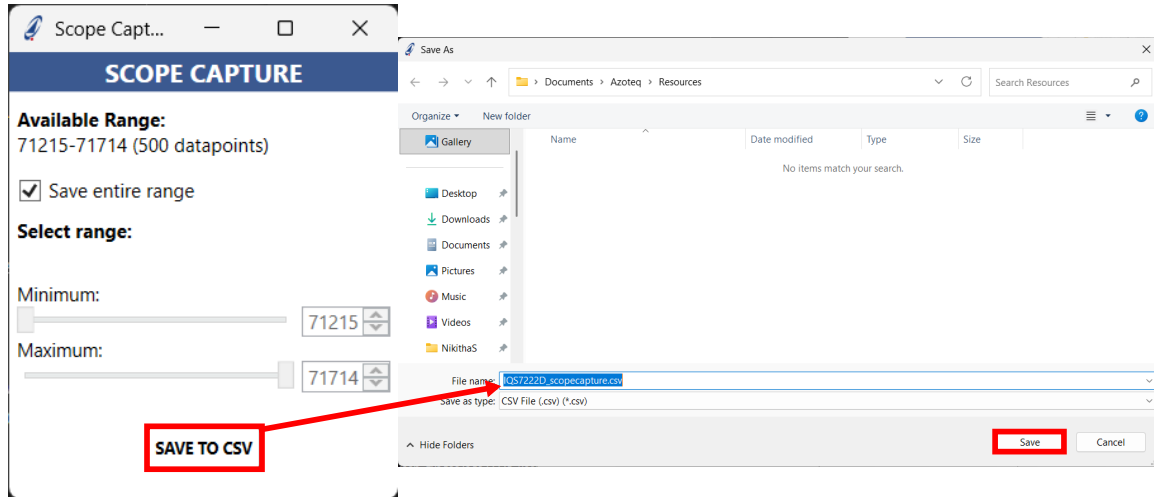

Figure 3.5: Save Streamed Data to CSV File Format

### 3.1.3 Slider

The IQS7222D can be configured to use up to four capacitive sensors as a touch slider, providing features such as swipe detection. Up to two sliders are supported. The measured coordinates of a finger on each touch slider is shown at the bottom of the GUI window.

## 3.2 Data Logging

It may be necessary to save all the above streaming data to a file for debugging or testing purposes. The logging function allows the GUI to save all streaming data from the IQS7222D to a CSV file. Click the “Logging” button in the Configuration Tool Manager panel to open the logging window.



Figure 3.6: Logging Function Using the Configuration Tool Manager

From here, the desired variables from the IQS7222D can be enabled or disabled. To start logging, click the “Start Logging” button, and choose the destination of the CSV log file.

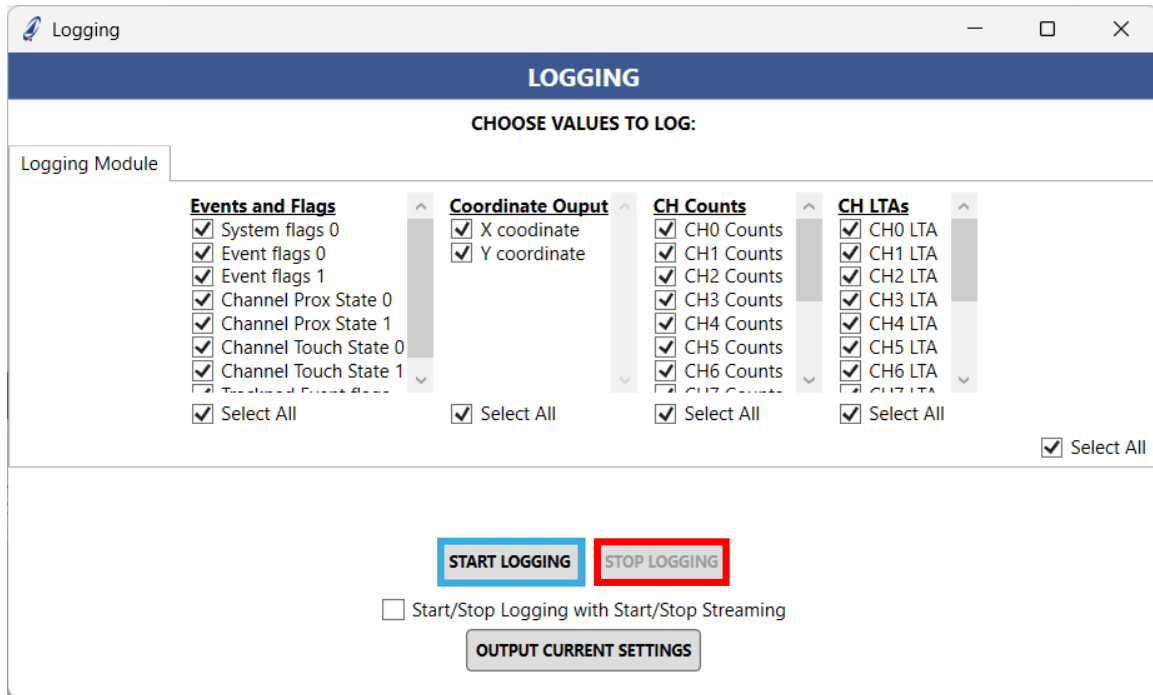

Figure 3.7: Logging Configuration Window

Once the file destination is confirmed, data logging will begin. To stop logging, click the “Stop Logging” button.

### 3.3 Export Device Configuration to H-File

After configuring the IQS7222D, you can export the new settings for safekeeping, sharing, or future use on the same or another device. The settings are exported as a .h-header file using the “Export H File” button.

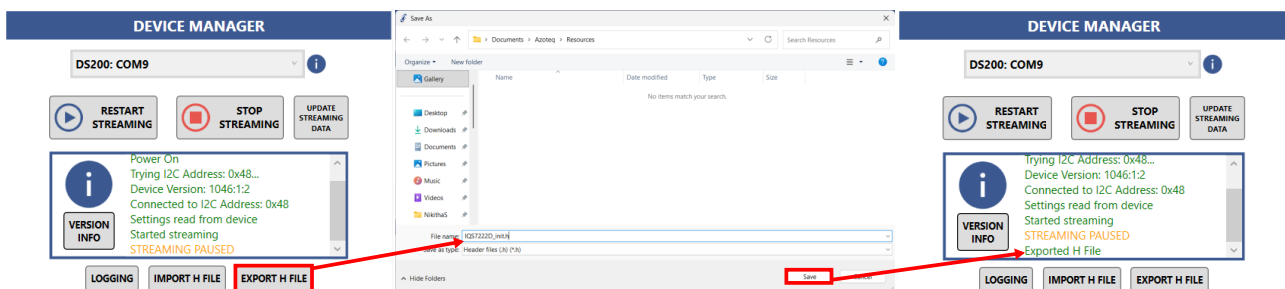

Figure 3.8: Exporting a Defined Configuration

### 3.4 Import Preconfigured H-File

If the device was previously configured and an associated .h-file was exported from the GUI, the file may now be imported into the GUI and loaded onto the IQS7222D using the “Import H File” button.

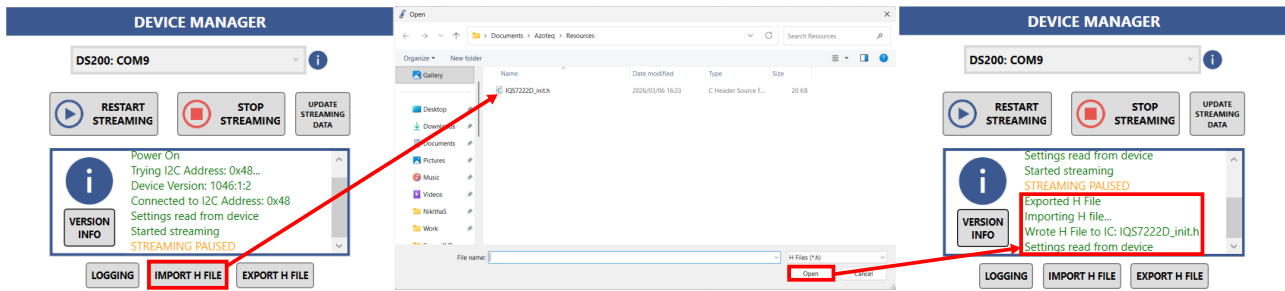

Figure 3.9: Importing a Predefined Configuration

### 3.5 Command Buttons

At the top centre of the GUI is a row of buttons that execute commonly-used commands.



Figure 3.10: Command Buttons

#### 3.5.1 Acknowledge Reset

The “Ack Reset” button clears the IQS7222D’s reset flag by writing the **Acknowledge Reset** bit to the IC. This should be the first step after powering on any Azoteq IQS-device. On start-up, the IC will set its Reset flag to indicate that a reset event has occurred. Writing a ‘1’ to the Acknowledge Reset bit clears this Reset flag.

If a reset of the IQS7222D occurs, the GUI will indicate this by changing the Ack Reset button colour to red.

#### 3.5.2 Soft Reset

The “Soft Reset” button issues a command to the IQS7222D to perform a soft reset. This can be used to clear any configured settings back to their default values.

#### 3.5.3 ATI All and Read

The “ATI All and Read” button writes the **Re-ATI** command to the IQS7222D. The ATI routine is a calibration algorithm on the IC that will recalibrate all the sensors to their target or reference counts.

Once ATI is complete, the GUI reads all the IQS7222D settings to update any parameters that the ATI routine may have changed.

#### 3.5.4 Reseed

The “Reseed” command can be used to update the LTA of the ProxFusion channel by setting it equal to the counts. Note that the Reseed command may trigger an ATI routine if the resulting LTA is significantly different from the target.



### 3.6 Trackpad

The panel on the top right-hand side of the GUI, Figure 3.11 shows movement on the trackpad.

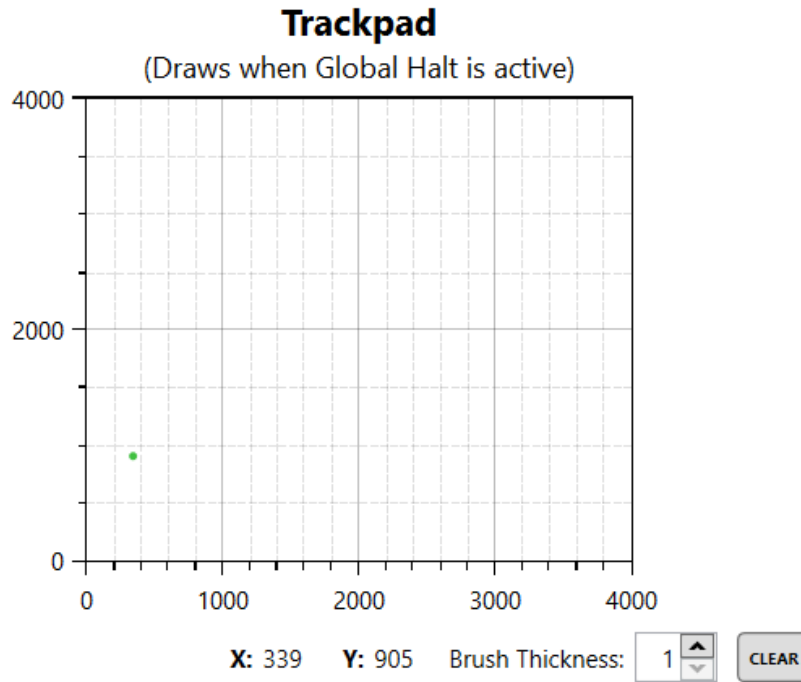

*Figure 3.11: Trackpad*



### 3.7 Events

The panel on the bottom right-hand side of the GUI shows the current event flags that are set on the IC, as shown in Figure 3.12. These indicators are read from the IQS7222D’s status registers.

The conditions for each event to trigger are described in the device datasheet.

#### 3.7.1 System Status

The following flags are read from the *System Status* register.

- > **ATI Active:** The IQS7222D is currently calibrating the channels.
- > **ATI Error:** The IQS7222D failed to calibrate one or more channels correctly.
- > **Reset:** A reset event has occurred, and all settings have been reset to defaults.
- > **Normal Power Update:** In Ultra-Low Power (ULP) mode, the IQS7222D is currently performing a “Normal Power” update cycle, which samples all channels and updates all LTA values.
- > **Global Halt:** The LTA values are halted for all channels that have Global Halt enabled. The Global Halt flag is set whenever one of the channels with Global Halt enabled is in a prox or touch state.
- > **Current Power Mode:** Indicates the current power mode of the device.

#### 3.7.2 Events

The following flags are read from the *Events* register.

- > **Prox:** The proximity state of one of the channels had changed.
- > **Touch:** The touch state of one of the channels had changed.
- > **Trackpad:** The trackpad state of one of the channels had changed.
- > **ATI:** An ATI event occurred, and some calibration values may have been updated.
- > **Power:** The power mode has recently changed.

EVENTS		VIEW LOG
SYSTEM FLAGS 0		
ATI Active	ATI Error	
Reset	Normal Power Update	
Global Halt		
SYSTEM FLAGS 1		
Prox Event	Touch Event	
SYSTEM FLAGS 2		
Trackpad Event	ATI Event	
Power Event		
TRACKPAD EVENTS		
Tap event	Flick event	

**Swipe event:**

**Current Power Mode:** Normal Power

Figure 3.12: Events Panel



## 4 Reference Design

### 4.1 IQS7222DEV01

#### 4.1.1 General-Purpose Stamp Module

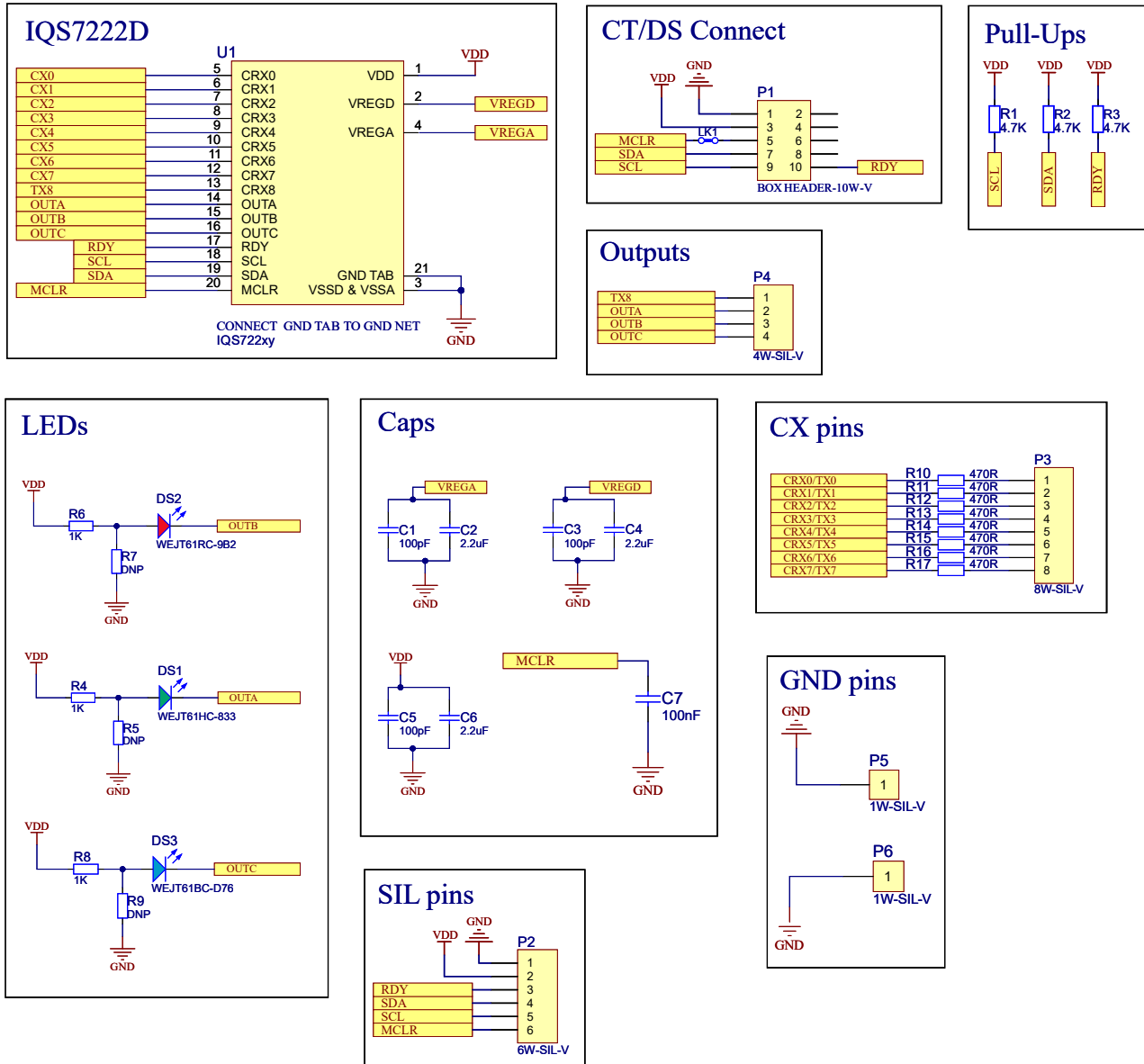

Figure 4.1: General-Purpose Stamp Reference Schematic



## 4.2 IQS7222D Module in the EVO2 EV Kit

### 4.2.1 Trackpad Module

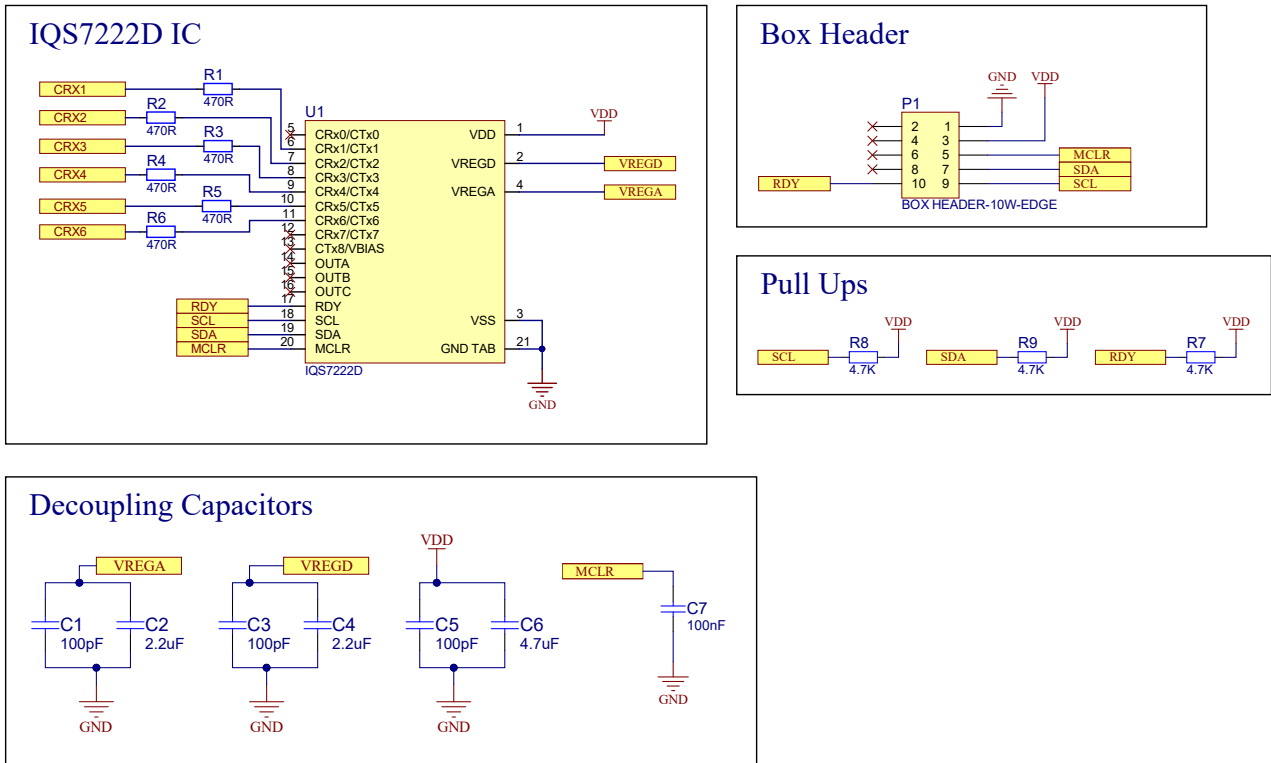

Figure 4.2: Trackpad Reference Schematic



## Contact Information

	South Africa (Headquarters)	China
<b>Physical Address</b>	1 Bergsig Avenue Paarl 7646 South Africa	Room 501A, Block A T-Share International Centre Taoyuan Road, Nanshan District Shenzhen, Guangdong, PRC
<b>Tel</b>	+27 21 863 0033	+86 755 8303 5294 ext 808
<b>Email</b>	info@azoteq.com	info@azoteq.com

	USA	Taiwan
<b>Physical Address</b>	7000 North Mopac Expressway Suite 200 Austin TX 78731 USA	Xintai 5th Road, Sec. 1 No. 99, 9F-12C Xizhi District 221001 New Taipei City Taiwan
<b>Tel</b>	+1 512 538 1995	+886 932 219 444
<b>Email</b>	info@azoteq.com	info@azoteq.com

*Visit [www.azoteq.com](http://www.azoteq.com)  
for a list of distributors and worldwide representation.*

Patents as listed on [www.azoteq.com/patents-trademarks/](http://www.azoteq.com/patents-trademarks/) may relate to the device or usage of the device.

Azoteq®, Crystal Driver®, IQ Switch®, ProxSense®, ProxFusion®, LightSense™, SwipeSwitch™, Dycal™, TriggerMax™, WearMax™, and the  logo are trademarks of Azoteq.

The information in this Datasheet is believed to be accurate at the time of publication. Azoteq uses reasonable effort to maintain the information up-to-date and accurate, but does not warrant the accuracy, completeness or reliability of the information contained herein. All content and information are provided on an “as is” basis only, without any representations or warranties, express or implied, of any kind, including representations about the suitability of these products or information for any purpose. Azoteq disclaims all warranties and conditions with regard to these products and information, including but not limited to all implied warranties and conditions of merchantability, fitness for a particular purpose, title and non-infringement of any third party intellectual property rights. Azoteq assumes no liability for any damages or injury arising from any use of the information or the product or caused by, without limitation, failure of performance, error, omission, interruption, defect, delay in operation or transmission, even if Azoteq has been advised of the possibility of such damages. The applications mentioned herein are used solely for the purpose of illustration and Azoteq makes no warranty or representation that such applications will be suitable without further modification, nor recommends the use of its products for application that may present a risk to human life due to malfunction or otherwise. Azoteq products are not authorized for use as critical components in life support devices or systems. No licenses to patents are granted, implicitly, express or implied, by estoppel or otherwise, under any intellectual property rights. In the event that any of the abovementioned limitations or exclusions does not apply, it is agreed that Azoteq’s total liability for all losses, damages and causes of action (in contract, tort (including without limitation, negligence) or otherwise) will not exceed the amount already paid by the customer for the products. Azoteq reserves the right to alter its products, to make corrections, deletions, modifications, enhancements, improvements and other changes to the content and information, its products, programs and services at any time or to move or discontinue any contents, products, programs or services without prior notification. For the most up-to-date information and binding Terms and Conditions please refer to [www.azoteq.com](http://www.azoteq.com).