



IQS325 DATASHEET

On-/Off-Axis Hall-Rotation Sensor With Adjustable Interval UI, Quadrature and Inductive/Capacitive ProxFusion® Channel.

1 Device Overview

The IQS325 ProxFusion® IC is a sensor fusion device for rotation and angle sensing applications using a diametrically polarised magnet in an on-axis or off-axis configuration. The included ProxFusion® channel can be used for integrated UI applications or as a wake-up channel. Standalone mode and quadrature outputs allow the IQS325 to be used as a drop-in replacement for mechanical rotary encoders.

1.1 Main Features

- > Highly Flexible ProxFusion® Device
- > Hall-Effect Angle Sensor
 - 4 Hall plates
 - On-/Off-axis orientation
 - 16-bit absolute angle output
 - <1° angle errorⁱ
 - Wide operational range
 - Automatic Tuning Implementation (ATI)
- > ProxFusion® Channel
 - Supports self-capacitive or inductive sensing
 - Automatic Tuning Implementation (ATI)
 - Button UI to detect large changes
 - Movement UI to detect small/rapid changes
 - Integrates with Hall angle sensor for virtual freewheel UI
- > Interval UI
 - Configurable number of intervals per rotation
 - Configurable hysteresis between intervals
- > Virtual Freewheel/Hyperscroll UI
 - Integrates the ProxFusion® Movement UI with the Hall sensor to detect “flick” gestures
 - Emulates a freely-spinning wheel – adds hyperscroll functionality to devices without expensive mechanical assemblies
- > UI Options
 - Automatic synchronisation with mechanical ratchets
 - Configurable number of intervals per rotation
 - Configurable hysteresis between intervals
 - Inductive force based Infinite scroll.
- > I²C Interface With IRQ/RDY Signal
- > Standalone Mode
 - Quadrature outputs indicate interval change and direction
 - GPIO output to indicate button press on the ProxFusion® channel
- > Design Simplicity
 - PC software for configuration and debugging
 - Guidelines for magnet selection and mechanical constraints
- > Supply Voltage: 1.71 V to 3.6 V

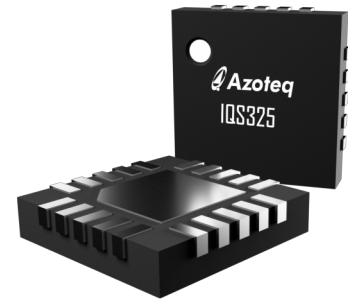

Figure 1.1: IQS325
QFN20 Package

ⁱ Dependent on magnet alignment and mechanical tolerances



- > Available packages:
 - QFN20 Package (3 × 3 × 0.5 mm – 0.4 mm pitch)
 - WLCSP11 Package (1.35 × 1.35 × 0.5 mm)

1.2 Applications

- > Scroll wheels and thumb wheels for computer peripherals
- > Applications requiring flexible UI options with sensor fusion
- > Mechanical and optical rotary encoder replacements
- > Adjustment and control knobs

1.3 Block Diagram

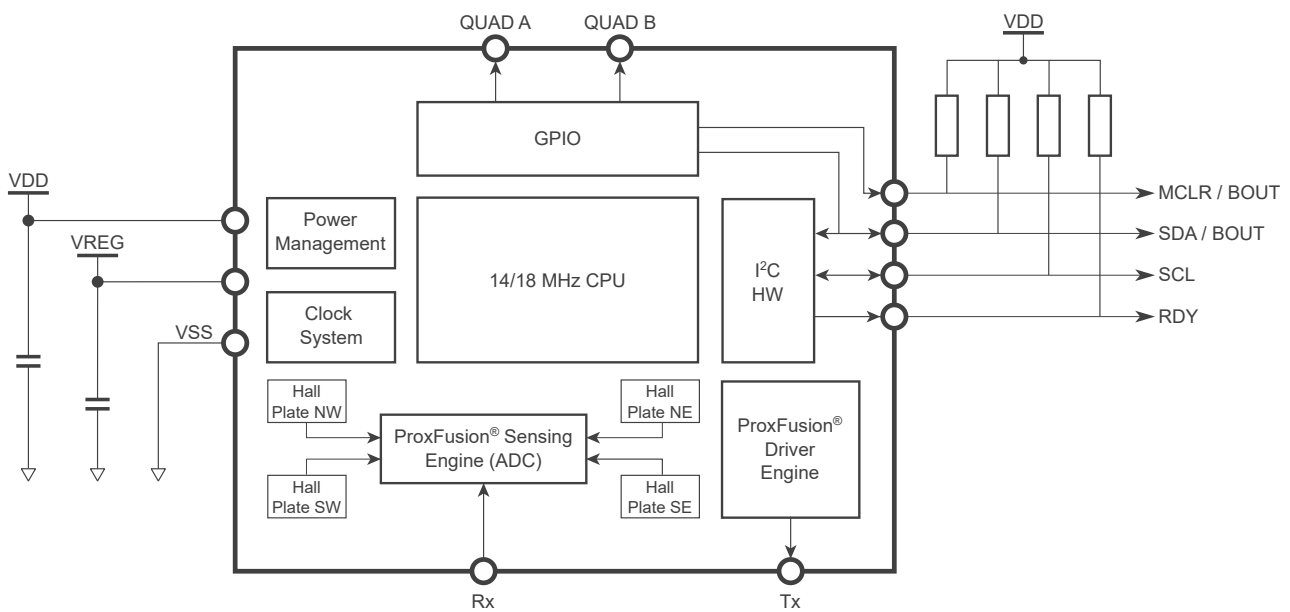

Figure 1.2: IQS325 Block Diagram



Contents

1	Device Overview	1
1.1	Main Features	1
1.2	Applications	2
1.3	Block Diagram	2
2	Hardware Connections	7
2.1	QFN20 Pinout	7
2.2	QFN20 Hall Plate Positions	8
2.3	WLCSP11 Pinout	9
2.4	WLCSP11 Hall Plate Positions	10
2.5	QFN20 and WLCSP11 Hall Plate Positions	10
2.6	Reference Schematic	10
3	Electrical Specifications	12
3.1	Absolute Maximum Ratings	12
3.2	General Operating Conditions	12
3.3	Recommended Operating Conditions	12
3.4	ProxFusion [®] Electrical Characteristics	13
3.5	ESD Rating	13
3.6	Reset Levels	13
3.7	Digital I/O Characteristics	13
3.8	I ² C Characteristics	14
3.9	Current Consumption	14
3.9.1	Current Consumption With Two Active Hall Plates	14
3.9.2	Current Consumption With Four Active Hall Plates	15
4	ProxFusion[®] Hall Sensor Module	17
4.1	Magnet Orientation	17
4.2	Hall Rotation Measurements	18
4.3	Hall Rotation Channels	19
4.3.1	Hall Plate Selection	19
4.3.2	Hall Differentials and Phase Angle	20
4.3.3	Calculating the Phase Angle	21
4.4	Automatic Tuning Implementation (ATI)	21
4.4.1	Runtime ATI	21
4.5	Filtering	22
4.6	Interval UI	22
4.6.1	Interval Hysteresis	22
4.7	High-Accuracy Mode	23
4.8	Stationary Detection	23
4.9	Angle Offset Compensation	23
4.10	Automatic Interval Centering	24
4.11	Quadrature Output	25
4.12	Buffered Intervals	26
5	Hall Normalisation	27
5.1	Normalisation Modes	27
5.2	Normalisation Default Values	27
5.3	Factory Calibration	27



6	ProxFusion[®] Channel	29
6.1	Sensing Modes	29
6.2	Counts	29
6.2.1	Counts Linearisation	29
6.3	Button Event Detection	30
6.3.1	Long-Term Average	30
6.3.2	Direction	31
6.3.3	LTA Reseeding	31
6.4	Movement Event Detection	31
6.4.1	Long-Term Average	31
6.4.2	Movement Flags	32
6.5	Dormancy	32
6.6	Automatic Tuning Implementation	32
6.7	Automatic Re-ATI	33
6.8	Debouncing and Hysteresis	33
6.9	Button GPIO	33
7	Freewheel UI	35
7.1	Effects of Freewheel Parameters	35
8	Power Options	37
8.1	Power Modes	37
8.2	AutoProx	38
8.2.1	AutoProx Limits	39
8.2.2	AutoProx Update Rate	39
9	Additional Features	40
9.1	Debug and Display Software (GUI)	40
9.2	Main Oscillator	40
9.3	Watchdog Timer (WDT)	40
9.4	Reset	40
9.4.1	Reset Indication	40
9.4.2	Software Reset	41
10	I²C Interface	42
10.1	I ² C Module Specification	42
10.2	I ² C Address	42
10.2.1	Reserved I ² C Address	42
10.3	I ³ C Compatibility	42
10.4	Memory Map Addressing	42
10.5	Memory Map Data	42
10.6	RDY/IRQ	43
10.7	Read and Write Operations	43
10.7.1	I ² C Read From Specific Address	43
10.7.2	I ² C Write To Specific Address	43
10.7.3	Modifying Bits Over I ² C	44
10.8	I ² C Timeout	44
10.9	Terminate Communication	45
10.10	Invalid Communications Return	45
10.11	Event Mode Communication	45
10.11.1	Events	45
10.11.2	Force Communication	45



10.12	Optimising I ² C Streaming Transactions	46
10.12.1	Customisable I ² C Data Block	46
10.12.2	Default Read Address	47
11	I²C Memory Map	48
11.1	Version Information (0x0000)	48
11.2	Settings Registers (0x1000)	48
11.3	Data Registers (0x2000)	52
12	Ordering Information	56
12.1	Ordering Code	56
12.2	Top Marking	56
12.2.1	QFN20 Package	56
12.2.2	WLCSP11 Package	57
13	Package Information	58
13.1	QFN20 Package Outline	58
13.2	QFN20 Recommended Footprint	60
13.3	WLCSP11 Package Outline	61
13.4	WLCSP11 Recommended Footprint	62
13.5	Tape and Reel Specifications	63
A	Memory Map Descriptions	65
A.1	System Commands (0x1000)	65
A.2	System Settings (0x1001)	65
A.3	I ² C Settings (0x1002)	66
A.4	Event Mask (0x1003)	66
A.5	Power Settings (0x100A)	66
A.6	Autoprox Settings (0x100B)	67
A.7	Hall Plate Selection (0x1018)	67
A.8	Hall Plate Bias (0x1019)	67
A.9	Hall Amplifier Gain (0x101A)	68
A.10	Hall Initialisation Delay (0x101B)	68
A.11	Hall Conversion Timings (0x101C)	68
A.12	Hall Dividers (0x1022)	68
A.13	Rotation UI Settings (0x1030)	69
A.14	Quadrature Settings (0x1044)	69
A.15	CH0 Sensor Settings 0 (0x1046)	70
A.16	CH0 Sensor Settings 1 (0x1047)	70
A.17	CH0 Dividers (0x104E)	70
A.18	CH0 UI Settings (0x1052)	71
A.19	CH0 Button Debounce (0x1056)	71
A.20	CH0 Movement Debounce (0x105A)	71
A.21	Button Output Settings 0 (0x106C)	72
A.22	Hall Normalisation Mode (0x1085)	72
A.23	System Status (0x2000)	72
A.24	Event Flags (0x2001)	73
A.25	Hall Flags (0x2002)	73
A.26	Proxfusion States (0x2003)	74
A.27	Button Flags (0x2004)	74
A.28	Movement Flags (0x2005)	74



B Revision History

2 Hardware Connections

2.1 QFN20 Pinout

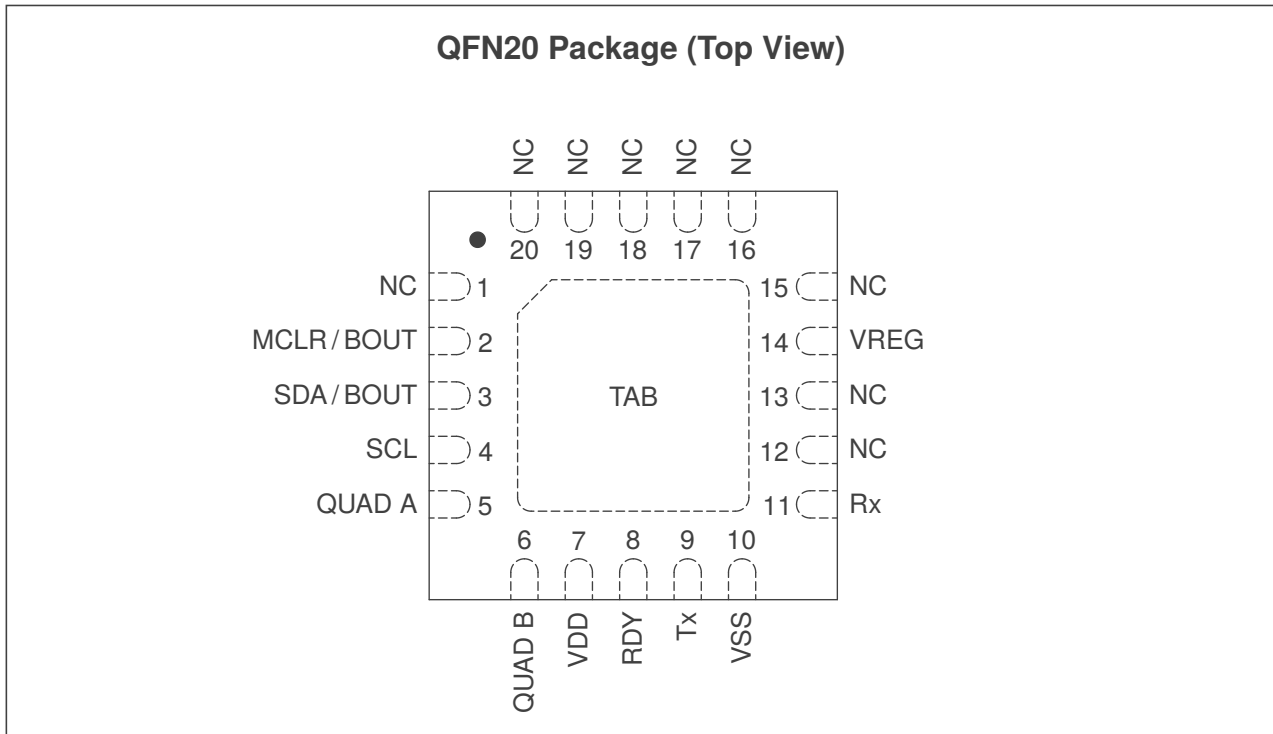

Figure 2.1: QFN20 Pinout

Table 2.1: QFN20 Pin Descriptions

Pin	Name	Type ⁱ	Function	Description
2	MCLR/BOUT	I/O	GPIO	Device reset request or emulates an active-low button output to indicate ProxFusion® (CH0) button state
3	SDA/BOUT	I/O	I ² C / GPIO	I ² C data in I ² C mode. Emulates an active-low button output to indicate ProxFusion® (CH0) button state in standalone mode.
4	SCL	I/O	I ² C	I ² C clock
5	QUAD A	O	GPIO	Quadrature pin
6	QUAD B	O	GPIO	Quadrature pin
7	VDD	P	Power	Power supply input voltage
8	RDY	O	I ² C	I ² C interrupt request, active low
9	Tx	O	ProxFusion®	ProxFusion® inductive Tx pad
10	VSS	P	Power	Analog/digital ground
11	Rx	I	ProxFusion®	ProxFusion® sensing pad
14	VREG	P	Power	Internally-regulated supply voltage
*	NC	-	-	Not connected

Continued on next page...



Table 2.1: QFN20 Pin Descriptions (Continued)

Pin	Name	Type ⁱ	Function	Description
	TAB	-	-	Thermal pad (floating). It is recommended to connect this to VSS.

ⁱ Pin Types: I = Input, O = Output, I/O = Input or Output, P = Power

2.2 QFN20 Hall Plate Positions

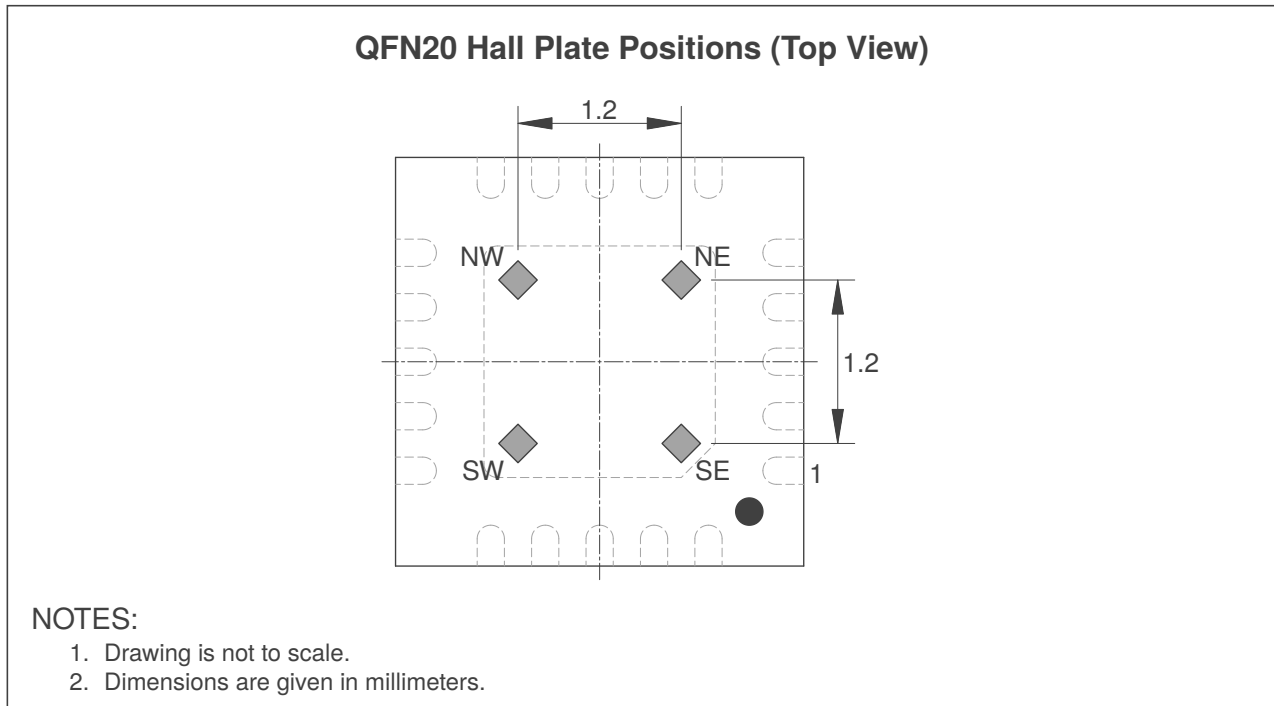

Figure 2.2: QFN20 Hall Plate Positions



2.3 WLCSP11 Pinout

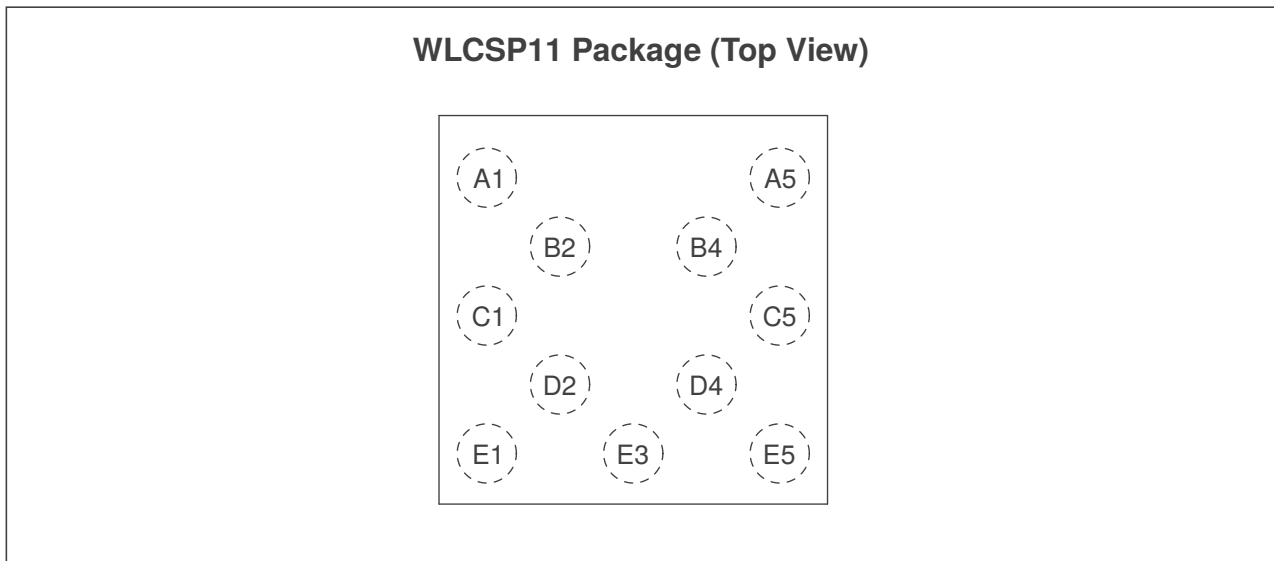

Figure 2.3: WLCSP11 Pinout

Table 2.2: WLCSP11 Pin Descriptions

Pin	Name	Type ⁱ	Function	Description
A1	SCL	I/O	I ² C	I ² C clock
A5	Rx	I	ProxFusion®	ProxFusion® sensing pad
B2	VDD	P	Power	Power supply input voltage
B4	VSS	P	Power	Analog/digital ground
C1	SDA/BOUT	I/O	I ² C/GPIO	I ² C data in I ² C mode. Emulates an active-low button output to indicate ProxFusion® (CH0) button state in standalone mode.
C5	VREG	P	Power	Internally-regulated supply voltage
D2	QUAD A	O	GPIO	Quadrature pin
D4	RDY	O	I ² C	I ² C interrupt request, active low
E1	MCLR/BOUT	I/O	GPIO	Device reset request or emulates an active-low button output to indicate ProxFusion® (CH0) button state
E3	QUAD B	O	GPIO	Quadrature pin
E5	Tx	O	ProxFusion®	ProxFusion® inductive Tx pad

ⁱ Pin Types: I = Input, O = Output, I/O = Input or Output, P = Power



2.4 WLCSP11 Hall Plate Positions

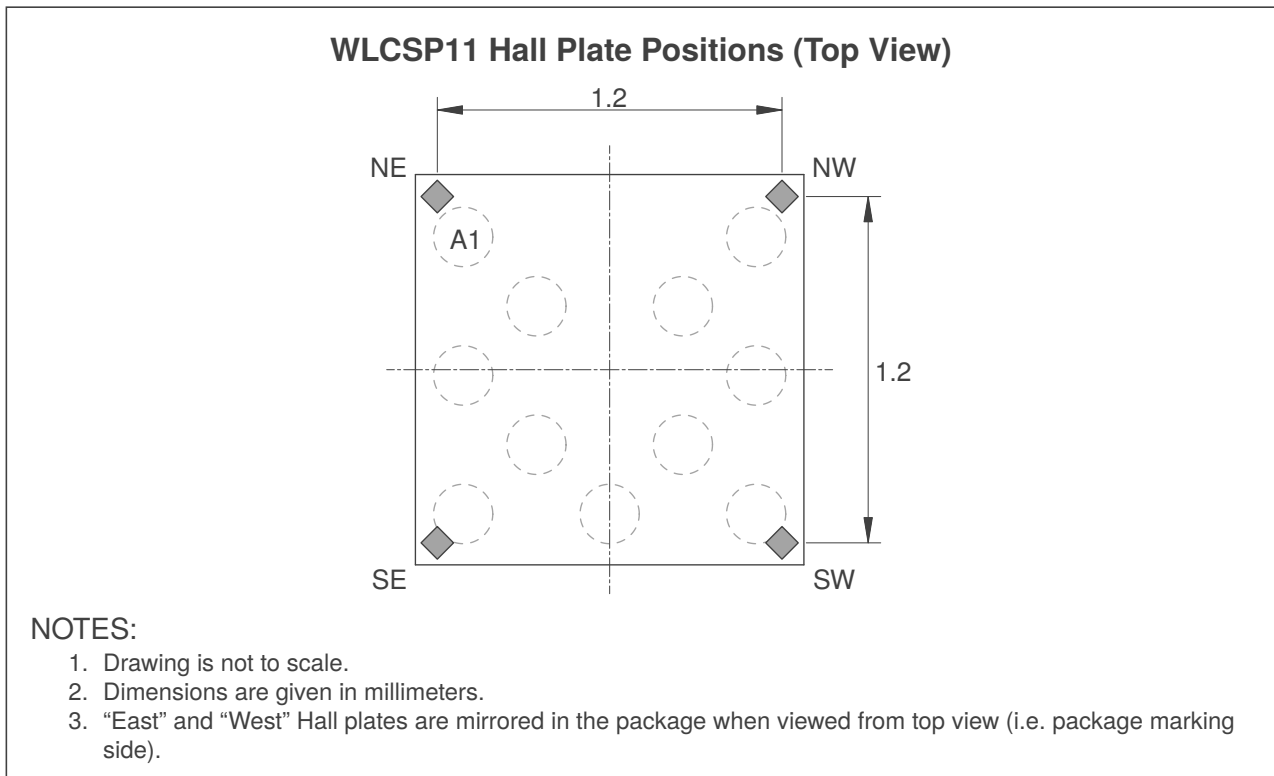

Figure 2.4: WLCSP11 Hall Plate Positions

2.5 QFN20 and WLCSP11 Hall Plate Positions

Please note that the Hall plate positions are different for the QFN20 and WLCSP11 packages. In the WLCSP11 package, the “East” and “West” Hall plates are mirrored in the package, compared to the QFN20 package. This has implications on rotation direction in on-axis applications, and on the Hall Plate Selection and IC orientation for off-axis applications.

2.6 Reference Schematic

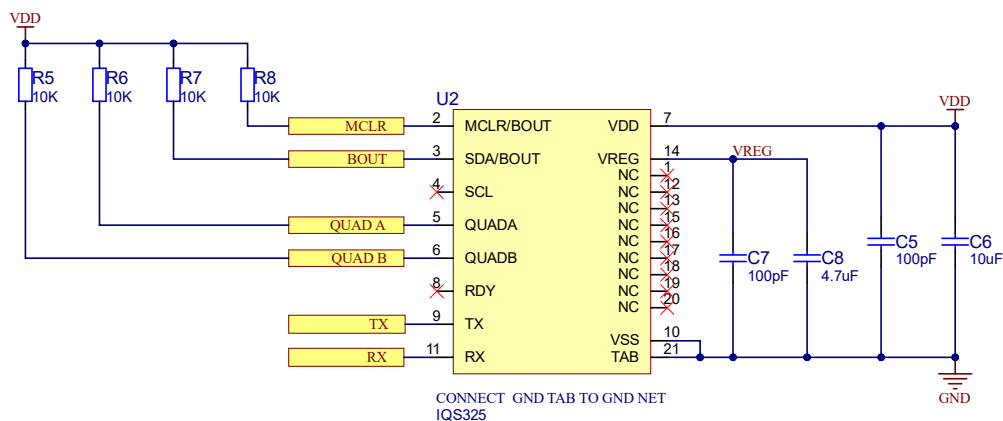

Figure 2.5: IQS325 Standalone Mode Reference Schematic



3 Electrical Specifications

3.1 Absolute Maximum Ratings

Table 3.1: Absolute Maximum Ratings

Symbol	Rating	Min	Max	Unit
V _{DD}	Voltage applied at VDD pin (referenced to VSS)	-0.3	3.6	V
V _{IN}	Voltage applied to any ProxFusion® pin (referenced to VSS)	-0.3	V _{REG}	V
	Voltage applied to any other pin (referenced to VSS)	-0.3	V _{DD} + 0.3 (3.6 V max)	V
T _{stg}	Storage temperature	-40	85	°C

3.2 General Operating Conditions

Table 3.2: General Operating Conditions

Symbol	Parameter	Condition	Typ	Unit
f _{OSC}	Master clock frequency	f _{OSC} = 14 MHz	14	MHz
		f _{OSC} = 18 MHz	18	
f _{PROX}	ProxFusion® engine clock frequency		f _{OSC}	MHz
V _{REG}	Internally-regulated supply output	f _{OSC} = 14 MHz	1.53	V
		f _{OSC} = 18 MHz	1.8	

3.3 Recommended Operating Conditions

Table 3.3: Recommended Operating Conditions

Symbol	Parameter	Condition	Min	Rec ⁱ	Max	Unit
V _{DD}	Standard operating voltage, applied at VDD pin	f _{OSC} = 14 MHz	1.71		3.6	V
		f _{OSC} = 18 MHz	2.2			
T _A	Operating free-air temperature		-20		85	°C
C _{VDD}	Recommended capacitor at VDD		C _{VREG}	2×C _{VREG}		μF
C _{VREG}	Recommended external buffer capacitor at VREG (ESR ≤ 200 mΩ)		2.2 ⁱⁱ	4.7	10	μF

ⁱ Recommended value

ⁱⁱ Absolute minimum allowed capacitance value is 1 μF, after taking derating, temperature, and worst-case tolerance into account. Please refer to [AZD004](#) for more information regarding capacitor derating.



3.4 ProxFusion® Electrical Characteristics

Table 3.4: Recommended Operating Conditions for ProxFusion® Pins

Symbol	Parameter	Min	Max	Unit
$C_{XSELF-VSS}$	Capacitance between ground and external electrodes, in self-capacitance mode	1	400 ⁱ	pF
$R_{Cx(SELF)}$	Series in-line resistance of self-capacitance electrodes	0	1 ⁱⁱ	kΩ

ⁱ $R_{Cx} = 0 \Omega$

ⁱⁱ Series resistance limit is a function of F_{xfer} and the circuit time constant, RC . $R_{max} \times C_{max} = 1/(10 \times F_{xfer})$, where C is the pin capacitance to VSS.

3.5 ESD Rating

Table 3.5: ESD Rating

			Value	Unit
$V_{(ESD)}$	Electrostatic discharge voltage	Human-body model (HBM), per ANSI/ESDA/JEDEC JS-001 ⁱ	±2000	V

ⁱ JEDEC document JEP155 states that 500 V HBM allows safe manufacturing with a standard ESD control process. Pins listed as ±2000 V may actually have higher performance.

3.6 Reset Levels

Table 3.6: Reset Levels

Parameter		Min	Max	Unit
V_{DD}	Power-up (Reset trigger) – slope > 100 V/s	1.65		V
	Power-down (Reset trigger) – slope < -100 V/s		0.9	

3.7 Digital I/O Characteristics

Table 3.7: Digital I/O Characteristics

Parameter		Test Conditions	Min	Max	Unit
V_{OL}	SDA & SCL output low voltage	$I_{sink} = 20 \text{ mA}$		0.3	V
	GPIO output low voltage	$I_{sink} = 10 \text{ mA}$		0.15	V
V_{OH}	Output high voltage	$I_{source} = 20 \text{ mA}$	$V_{DD} - 0.2$		V
V_{IL}	Input low voltage		$V_{SS} - 0.3$	$0.3 \times V_{DD}$	V
V_{IH}	Input high voltage		$0.7 \times V_{DD}$	$V_{DD} + 0.3$	V
I_{GPIO}	Output current sunk by any GPIO pin			10	mA
	Output current sourced by any GPIO pin			20	
C_b	SDA & SCL bus capacitance			550	pF

3.8 I²C Characteristics

Table 3.8: I²C Characteristics

Parameter		Min	Max	Unit
f _{SCL}	SCL clock frequency		1000	kHz
t _{HD,STA}	Hold time (repeated) START condition	0.26		μs
t _{LOW}	LOW period of the SCL clock	0.5		μs
t _{HIGH}	HIGH period of the SCL clock	0.26		μs
t _{SU,STA}	Set-up time for a repeated START condition	0.26		μs
t _{HD,DAT}	Data hold time	0		ns
t _{SU,DAT}	Data set-up time	50		ns
t _{SU,STO}	Set-up time for STOP condition	0.26		μs
t _{BUF}	Bus free time between a STOP and START condition	0.5		μs
t _{SP}	Pulse duration of spikes suppressed by input filter	0	50	ns

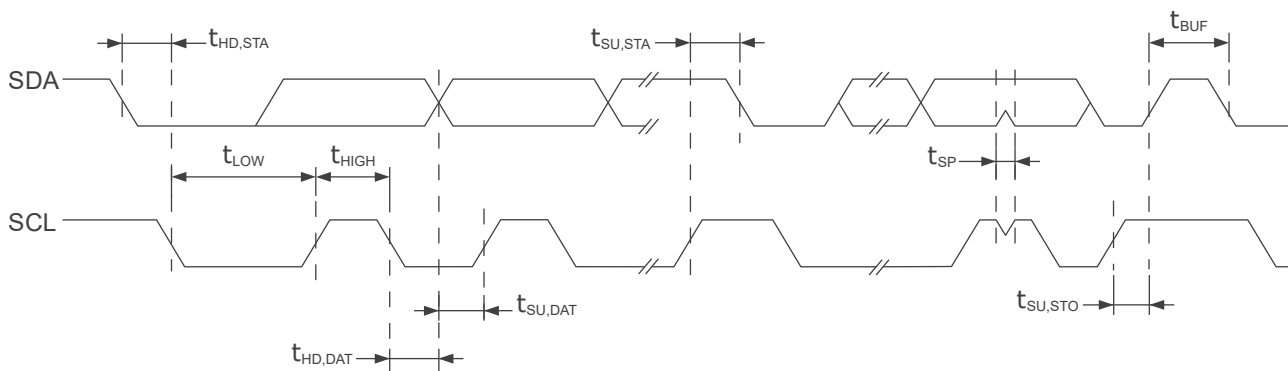

Figure 3.1: I²C Timing Diagram

3.9 Current Consumption

The current consumption of the IQS325 is highly dependent on the specific parameters configured during initialisation, as well as on the frequency and duration of I²C communications. Therefore, the following tables serve as an illustration of the expected power consumption for similar configurationsⁱ. All measurements are taken with *Event Mode* enabled, without any sensor activations, and without any I²C communications. All other settings, unless stated otherwise, are kept default.

Current consumption values are provided for both 14 MHz and 18 MHz F_{OSC} configurations. For more information, please refer to Section 9.2.

3.9.1 Current Consumption With Two Active Hall Plates

The following tables show the expected current consumption of the IQS325 in a diagonal off-axis configuration, where only two opposing corner Hall plates are sampled, as shown in Section 4.3.1.

Specific settings include:

ⁱ These measurements are based on bench testing and have not been characterised over large volumes.



- > ProxFusion Sensing Mode: Self-capacitive
- > ProxFusion Charge Transfer Frequency: 500 kHz
- > Normalisation: Auto
- > Hall Plate Selection: NE to SW
- > Phase angle: 20°

Table 3.9: IQS325 Typical Current Consumption at 14 MHz F_{osc}

Power Mode	Report Rate [ms]	Current Consumption [µA]		
		Hall & Touch	Hall	Touch
High Accuracy	5	410	360	270
Normal Power	40	70	60	45
Low Power	100	35	25	22
Ultra Low Power	200	15	12	10
Auto Prox	200	N/A	5	4
Halt	-	1.5		

Table 3.10: IQS325 Typical Current Consumption at 18 MHz F_{osc}

Power Mode	Report Rate [ms]	Current Consumption [µA]		
		Hall & Touch	Hall	Touch
High Accuracy	5	490	400	325
Normal Power	40	80	65	50
Low Power	100	35	28	22
Ultra Low Power	200	17	13	12
Auto Prox	200	N/A	5	4
Halt	-	1.5		

3.9.2 Current Consumption With Four Active Hall Plates

The following tables show the expected current consumption of the IQS325 in a configuration that samples all four Hall plates. This applies to an on-axis setup, or off-axis with “North-South” or “East-West” configuration.

Specific test settings include:

- > ProxFusion Sensing Mode: Self-capacitive
- > ProxFusion Charge Transfer Frequency: 500 kHz
- > Normalisation: Off
- > Hall Plate Selection: On-Axis
- > Phase angle: 90°



Table 3.11: IQS325 Typical Current Consumption at 14 MHz F_{osc}

Power Mode	Report Rate [ms]	Current Consumption [μ A]		
		Hall & Touch	Hall	Touch
High Accuracy	5	550	450	270
Normal Power	40	85	70	45
Low Power	100	40	30	22
Ultra Low Power	200	18	15	10
Auto Prox	200	N/A	5	4
Halt	-	1.5		

Table 3.12: IQS325 Typical Current Consumption at 18 MHz F_{osc}

Power Mode	Report Rate [ms]	Current Consumption [μ A]		
		Hall & Touch	Hall	Touch
High Accuracy	5	560	490	325
Normal Power	40	90	75	50
Low Power	100	40	35	25
Ultra Low Power	200	20	18	12
Auto Prox	200	N/A	5	4
Halt	-	1.5		



4 ProxFusion[®] Hall Sensor Module

The IQS325 contains four equally spaced Hall plates that measure the magnetic field strength and orientation of a nearby diametrically polarised magnet. These Hall plates are used to calculate the relative angle of a magnet with regard to the IC, in either on- or off-axis orientations. The angle can be divided into discrete intervals using the Interval UI, providing a convenient interface for scroll wheel applications.

4.1 Magnet Orientation

The IQS325 is designed to be used in on-axis or off-axis orientations with regard to the magnet.

On-axis is highly recommended for applications that require high accuracy and low jitter. This uses all four Hall plates, with 90° phase angle between them, to measure the relative angle between the magnet and the IC. This orientation is the most robust against mechanical tolerances and errors. A typical on-axis configuration is shown in Figure 4.1.

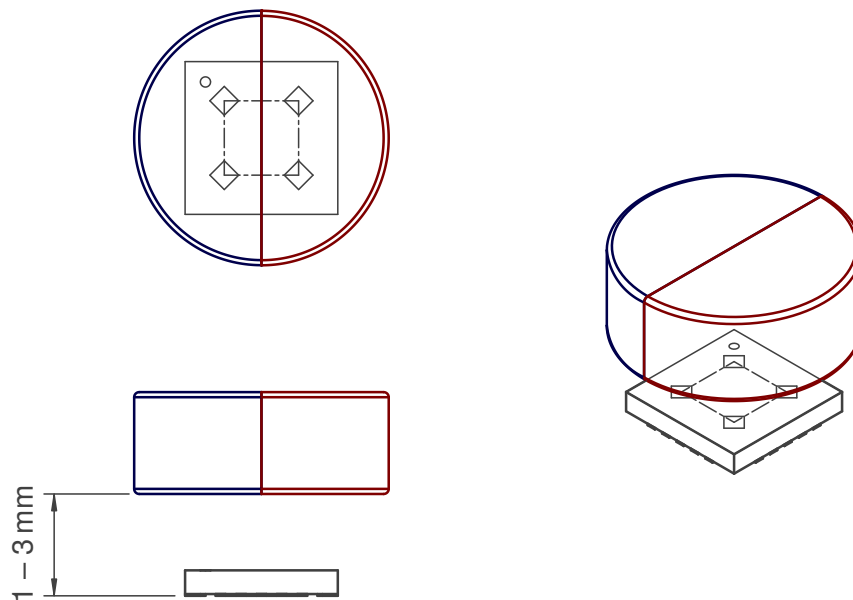

Figure 4.1: Magnet Orientation of an On-axis Angle Measurement Application

Off-axis may be used in applications where an on-axis setup may not be mechanically viable. Figure 4.2 shows the recommended configuration for an off-axis Hall-rotation sensor. Here, the magnet is orientated diagonally relative to the IC, and two diagonal plates are used for the rotation sensing. This is generally recommended if off-axis is required, as it provides the largest phase angle.

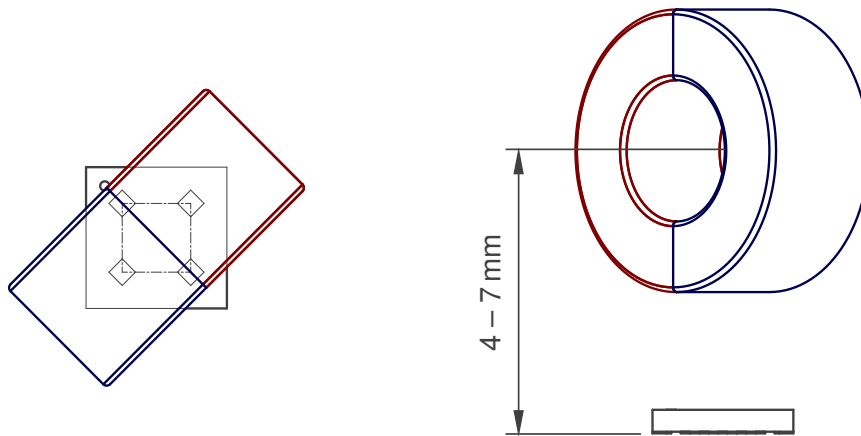

Figure 4.2: Recommended Diagonal Magnet Orientation for Off-Axis Angle Measurement Applications

Figure 4.3 shows an alternate off-axis configuration that uses two plates per side to measure the Hall rotation. This configuration results in a smaller phase angle than when using the diagonal plates and is thus only recommended for shorter distances between the magnet and IC.

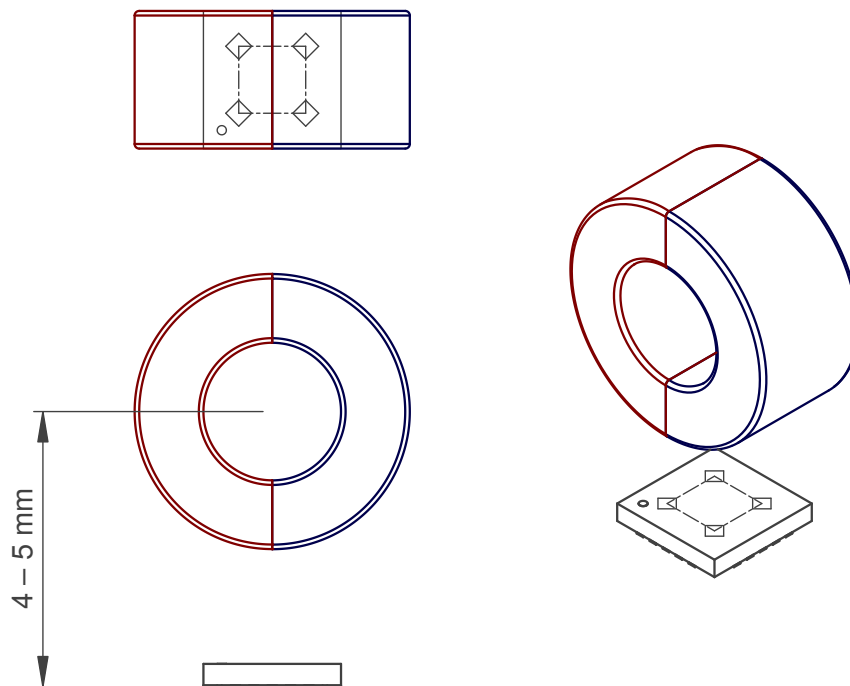

Figure 4.3: Alternate Magnet Orientation for Off-Axis Angle Measurement Applications

Please refer to Section 4.3.1 for settings related to on- and off-axis selections. Also refer to [AZD127: Hall-Rotation Design Guide](#) for more information regarding on-axis and off-axis design guidelines.

4.2 Hall Rotation Measurements

The IQS325 provides the angle measurement in three different values:

- > **Absolute Angle:** Raw angle measurement, provided as an unsigned 16-bit value, where the range [0, 65536) maps to [0°, 360°). This represents the angle of the magnet relative to the IC.



- > **Processed Angle:** Angle measurement after post-processing, also an unsigned 16-bit value. This output is filtered and includes an angular offset. This output can be used for applications requiring high-resolution measurements.
- > **Interval:** The output of the interval UI, which divides the unsigned 16-bit processed angle into several sections, or intervals. This output is recommended for applications with mechanical ratchets and is supplemented by the hysteresis and auto-zero features.

4.3 Hall Rotation Channels

The Hall-effect rotation measurement on the IQS325 relies on two measurements on each of the four Hall plates, where the second measurement is inverted to the first. These two measurements allow for the calculation of a reference value and a differential value, from which the relative strength of the magnetic field can be inferred. The reference value is calculated as the average of the two measurements, and the differential value is calculated as the difference between the measurements.

As a result, the IQS325 performs up to eight Hall-effect measurements, four of which are inverted to the others. These measurement values (channels) are available in the *Hall Plate Counts* and *Hall Reference* registers.

4.3.1 Hall Plate Selection

By default, the IQS325 uses opposing diagonal plates to measure off-axis magnet rotation. Either pair can be selected by modifying the *Hall Plate Selection* setting in the *Hall Plate Selection* register. The “diagonal axis” refers to the axis of rotation of the magnet. “NW to SE Axis” will use the NE and SW plates, and vice versa.

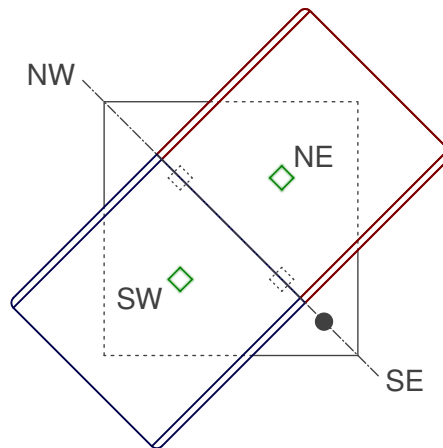

Figure 4.4: NW-SE Off-Axis Plate Selection

Alternatively, the “North-South (N-S)” or “West-East (W-E)” axes can be specified, which will use two pairs of plates to measure the off-axis rotation. “N-S” axis selection will use the East and West plates, and vice versa.

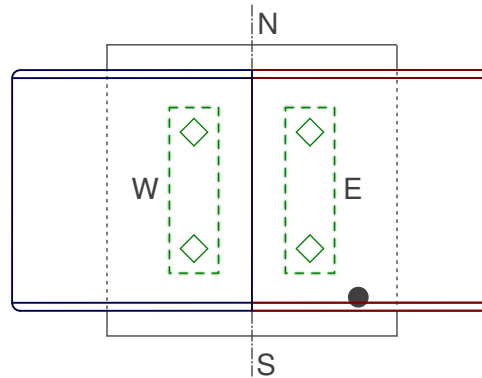

Figure 4.5: N-S Off-Axis Plate Selection

4.3.2 Hall Differentials and Phase Angle

For on-axis and off-axis configurations, the Hall counts are combined into two *Hall Differential* signals, which are used to calculate the magnet's angle. The phase angle between these two signals, illustrated in Figure 4.6, is dependent on the geometry of the application. This phase angle must be calibrated and set in the *Phase Angle* registers. With a measured phase angle, θ , the register values must be set to:

$$\text{Phase Angle Sin} = 65536 \times \sin(\theta)$$

$$\text{Phase Angle Cos} = 65536 \times \cos(\theta)$$

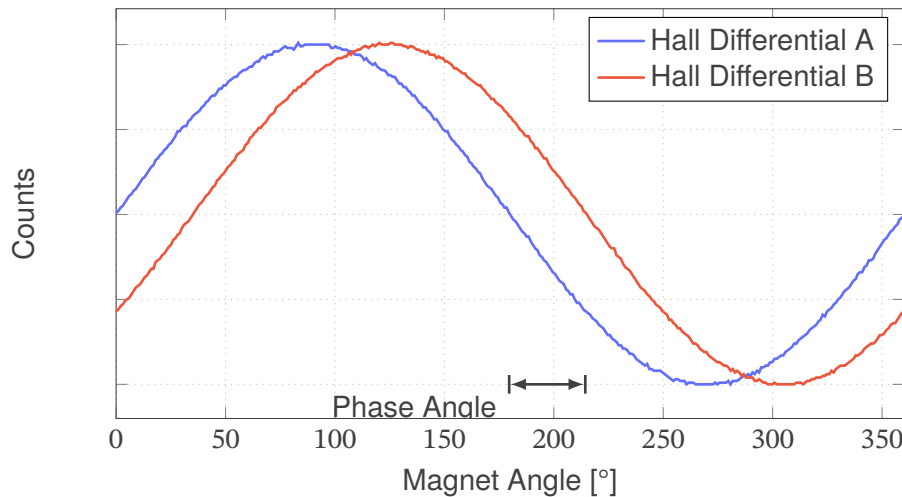

Figure 4.6: Hall Differential Signals

On-axis configurations always have a phase angle of 90°. In this case, the Phase Angle Cos register should be set to 0. Off-axis applications typically have a smaller phase angle, in the range of 20° to 40°.



4.3.3 Calculating the Phase Angle

To calculate the phase angle of an off-axis magnet setup, the two Hall Differential signals must be recorded over at least one full rotation of the magnet. These signals then need to be normalised with:

$$A_{norm} = \frac{\frac{\max(A)-A}{\max(A)-\min(A)}}{\min(A)} \quad B_{norm} = \frac{\frac{\max(B)-B}{\max(B)-\min(B)}}{\min(B)}$$

The data will now range between 0 and 1.

Sample both signals where $A_{norm} \approx 0.5$. With these values, the phase angle, θ , can be calculated as:

$$\theta = \arcsin(|B_{norm} - A_{norm}| \cdot 2) \quad (\text{where } A_{norm} \approx 0.5)$$

4.4 Automatic Tuning Implementation (ATI)

ATI is an automatic sensor calibration algorithm that configures the *Hall Plate Offsets* to ensure accurate Hall-effect sensing for a range of different magnet sizes and strengths. The ATI aims to modify the Hall plate settings such that the Hall channel reference values are within the range defined by the *ATI Target* and *ATI Band* parameters. The recommended value for the target is between 8000 and 14000.

The overall gain of the Hall sensing circuitry is controlled by three parameters:

- > *Hall Amplifier Gain*
- > *Hall Dividers*
- > *Hall Offsets*

The first two parameters, Hall Amplifier Gain and Hall Dividers, must be chosen at design time. This can be done with the aid of the IQS325 GUI. Typically, these can be chosen such that the Hall channels swing around ± 2000 to ± 4000 counts from the reference over a full rotation of the magnet. Once the gain parameters are chosen, they can be fixed for all modules across production. The ATI feature then uses the Hall Offset values to compensate automatically for any variation across production.

When tuning the Hall gain parameters, the Hall Amplifier Gain value (in the *Hall Plate Settings* register) can generally be set to a starting value of '1' (x2). Then, the Hall Dividers can be increased or decreased until the desired counts swing (± 2000 to ± 4000 counts) is achieved. Recommended Hall Divider values are given in Table A.1. It is generally recommended to keep the Hall Divider gain ratio lower than 1. If this provides insufficient gain, the Hall Amplifier Gain value should be increased as necessary.

4.4.1 Runtime ATI

ATI is performed automatically at start-up, as well as when all the following criteria are met:

- > The stationary flag is set; see Section 4.8.
- > The *Hall Reference* of a channel is outside the threshold defined by Equation (1).

$$|\text{Hall Target} - \text{Hall Reference}| > \text{Hall ATI Band} \quad (1)$$

- > Runtime ATI is enabled in the *Hall Plate Selection* register.



4.5 Filtering

The IQS325 includes a dynamic angle filter that increases its bandwidth based on the magnet's current speed. This allows the filter to remove most high-frequency noise while the magnet is stationary, and prevents the filter from aliasing during high-speed rotations. The overall strength of the filter can be adjusted with the *Angle Filter Beta* value.

In Low and Ultra Low power modes, the *Low Power Beta* is used instead. This should be set to a *larger* value than the normal beta value, to reduce measured jitter at lower report rates.

4.6 Interval UI

The interval UI divides the 16-bit Processed Angle into a value between 0 and the *Number of Intervals*, where the size of each interval is defined as:

$$\text{Interval Size} = \frac{2^{16}}{\text{Number of Intervals}}. \quad (2)$$

This is especially useful for applications that do not require a high measurement resolution or that use mechanical ratchets.

4.6.1 Interval Hysteresis

The Interval Hysteresis prevents the interval output from jittering between two intervals, causing unnecessary interval change events. The behaviour of the hysteresis is shown in Figure 4.7.

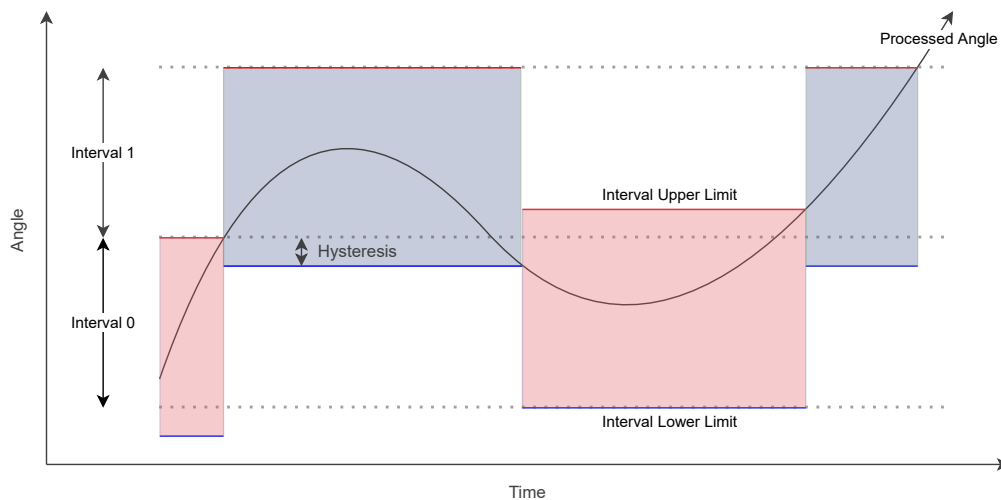

Figure 4.7: Illustration of the Interval Size and Interval Hysteresis

The amount of hysteresis applied can be modified by changing the *Interval Hysteresis* value. Hysteresis is a 16-bit value in the same unit as the Processed Angle. Hysteresis should therefore be chosen based on the interval size calculated in the previous section and on the amplitude of the noise on the Processed Angle.

4.7 High-Accuracy Mode

The High-Accuracy mode of the IQS325 will temporarily increase the report rate of the device to sample Hall rotation measurements more accurately and to reduce aliasing during high rotation rates.

The IQS325 will enter High-Accuracy mode in the event of:

- > An interval change,
- > Freewheeling, if the *Force High-Accuracy* bit is set under the *Hall UI Settings* register.

The *High-Accuracy* flag will remain set for the duration of the *High-Accuracy Timeout*. This flag is used to identify whether to transition into the High-Accuracy power mode, and can be configured to signal an automatic interval centering event when High-Accuracy mode is exited.

4.8 Stationary Detection

The IQS325 will set a *Stationary* flag if no movement is detected during the period defined by the *Stationary Timeout* value. This Stationary flag is used to identify whether to go into a lower power mode. Runtime ATI for the Hall channels is also only executed when stationary.

4.9 Angle Offset Compensation

Angle offset compensation is applied to ensure the output angle corresponds to the angle of the wheel, rather than the raw angle of the magnet, as shown in Figure 4.8. This is especially important for ratchet applications, where the intervals generated by the IC must match the mechanically defined intervals of the wheel.

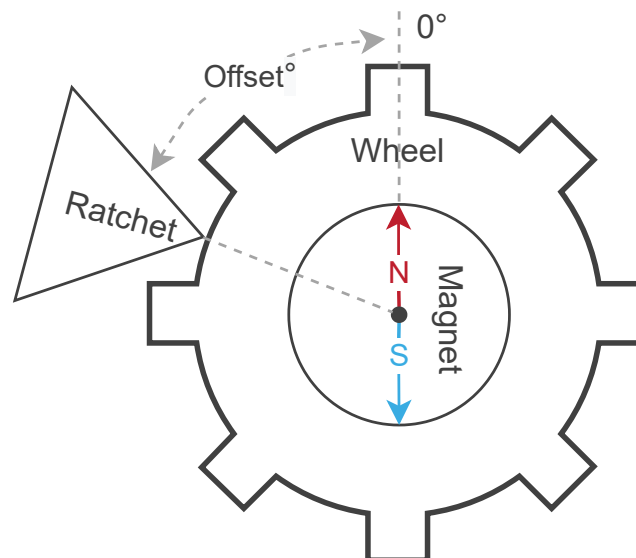

Figure 4.8: Illustration of the Absolute Angle Offset

The angle offset is updated when the *Zero* command in the *System Commands* register is set. This sets the Processed Angle to the centre of interval 0 and thus adjusts the angle offset accordingly. The *Zero* command is also set automatically on start-up.

The angle offset is also modified by the automatic interval centering functionality, to align the intervals with a mechanical ratchet automatically. Finally, freewheeling modifies the offset value to create the freewheel effect on the Processed Angle output.



The angle offset can be manually changed via the *Angle Offset* register.

4.10 Automatic Interval Centering

The interval centering functionality (or “auto-zero”) of the IQS325 allows the device to modify the absolute angle offset of the Processed Angle such that the Processed Angle is at the centre of the current interval. This dynamically adjusts the absolute angle offset until the Processed Angle aligns with the physical intervals of a ratchet device.

The auto-zero functionality can be set to one of five different modes in the *Hall UI Settings*:

- > **Off:** The device will never allow an automatic interval zero action to happen, and the master device will have to send an instruction over I²C to set the *Zero* bit.
- > **Stationary:** An auto-zero event will occur when the High-Accuracy timeout event occurs. A single adjustment is made to the absolute angle offset each time the device exits High-Accuracy mode. The *Auto-Zero Beta* parameter defines the size of the adjustment, with an auto-zero beta value of 0 resulting in a jump to the exact centre of the interval. This behaviour can be seen in Figure 4.9.
- > **Continuous:** The auto-zero filter will cause the Processed Angle to move continuously towards the centre of the current interval. It is recommended to use an auto-zero beta value of 6 or higher to allow the Processed Angle to move between intervals during slower rotations. This mode is recommended for devices without a mechanical ratchet. This behaviour can be viewed in Figure 4.10.
- > **Release:** An auto-zero event will occur on a Movement Exit event on the ProxFusion channel. If the ProxFusion channel is configured as a capacitive touch channel, this exit event could indicate that the user released the device.
- > **Continuous-Release:** Performs auto-zero using Continuous mode, but only while the ProxFusion Button event is not in activation. This automatically adjusts the angle offset as long as the user is not interacting or touching the device.

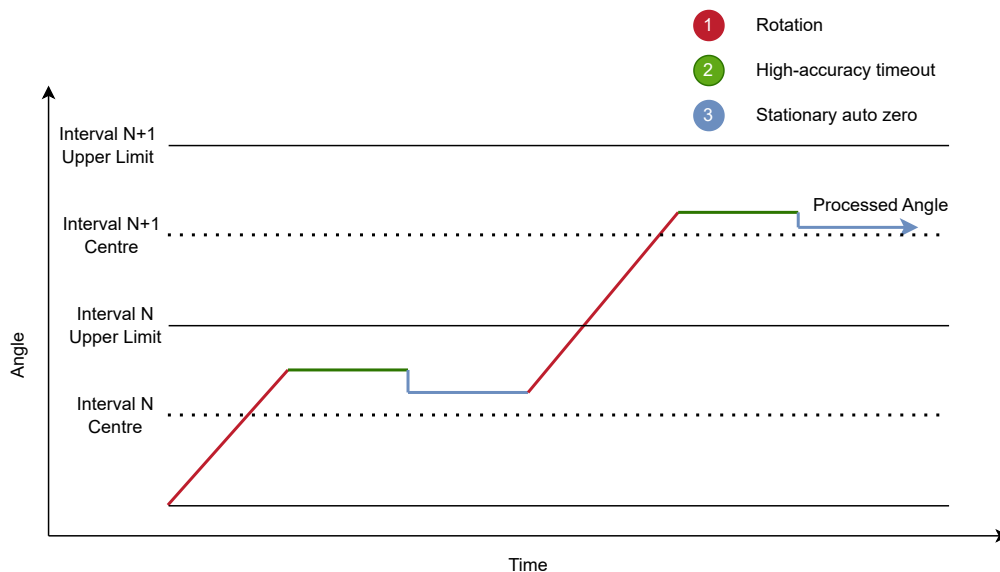

Figure 4.9: Stationary Auto-zero Behaviour

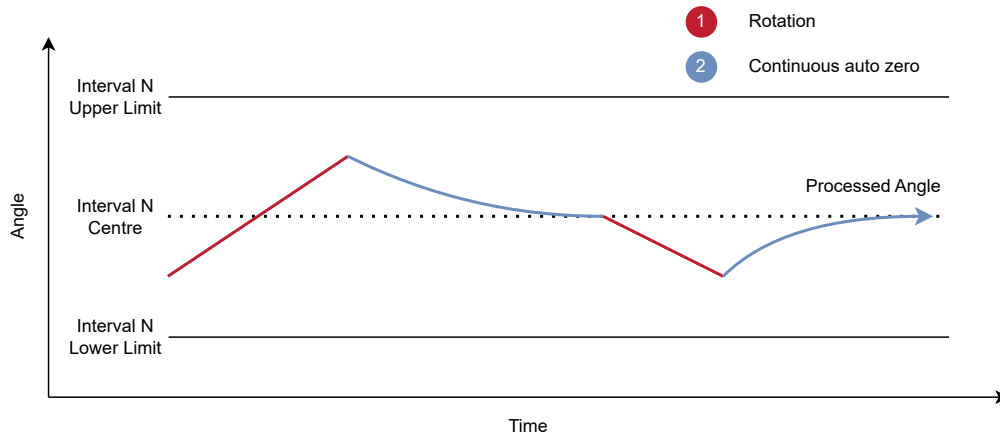

Figure 4.10: Continuous Auto-zero Behaviour

4.11 Quadrature Output

The quadrature output provides feedback over two GPIOs (QUAD_A and QUAD_B) when the value of the current interval changes. This functionality can be used for standalone applications where the master device would not need to poll the current interval value over I²C but would rather monitor the state of the two quadrature outputs. A visual example of the quadrature output is displayed in Figure 4.11.

A single interval change is represented by a rising or falling edge on both quadrature pins. The direction of the interval change is defined by which pin changes state first. For a positive rotation, the state of QUAD_A changes first, and for a negative rotation, the state of QUAD_B changes first. The period between the change in states of each quadrature output is defined by the *Quadrature Flank Delay* parameter. The quadrature flank delay parameter will also define the maximum report rate of the quadrature output.

The quadrature output pins can be configured as either push-pull or open-drain by setting the *Quadrature Mode* parameter. If open-drain mode is used, pull-up resistors must be added to the quadrature lines as shown in the reference schematic in Figure 2.5.

Note: The quadrature output can be fed directly into a standard quadrature decoder. Please note that, since some quadrature decoders expect only one GPIO edge per interval (instead of two), they will record twice the number of intervals.

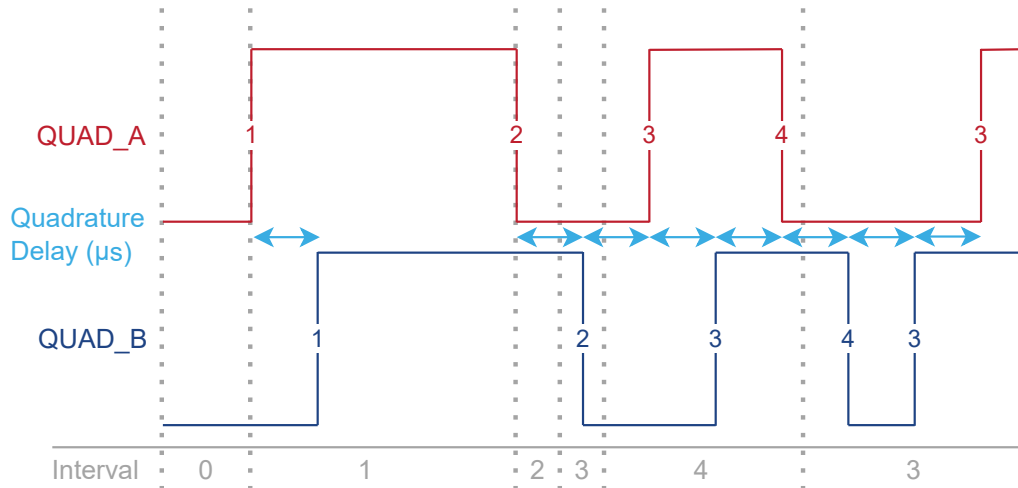

Figure 4.11: Quadrature IO Timing with Respect to Current Interval

Note the rapid change from interval 2 to 4 in Figure 4.11, resulting in a delayed output of the corresponding flanks so as not to overwhelm the receiving IC.

4.12 Buffered Intervals

During fast rotation, the rate at which intervals are processed may exceed the rate at which quadrature pulses are clocked out. These intervals are processed by the quadrature output peripheral at a later time. The buffered intervals can automatically be discarded when the device becomes stationary by setting the *Discard Intervals* bit in the *Quadrature Settings* register.



5 Hall Normalisation

Off-axis magnet orientations require extremely tight mechanical tolerances to ensure accurate Hall-rotation measurements. Magnet misalignments and wobble can result in differences in amplitudes of the measured magnetic field strengths across different Hall plates. To compensate for this, the IQS325 attempts to normalise the *Hall Differential* signals by tracking the minimum and maximum values of the Hall Differentials during runtime. These minimum and maximum values are then used to correct for differences in amplitude and DC offsets between the A and B Hall Differentials. Normalisation attempts to set the amplitude of the Differentials to approximately 16384 counts.

Min/max tracking is performed over the course of each full rotation, and the minimum and maximum values are stored in the *Normalisation Minimum/Maximum* registers. The resulting normalised Hall Differential signals are then stored in the *Normalised Differential* registers.

5.1 Normalisation Modes

Hall normalisation can be set to 'Off', 'Manual', or 'Auto'.

- > **Off:** Normalisation is disabled.
- > **Manual:** The Hall Differential signals are normalised based on the values stored in the Normalisation Min/Max registers. However, these normalisation values are static. The IQS325 does not perform any tracking of minimum and maximum Differentials.
- > **Auto:** The IQS325 performs min/max tracking with each rotation, continuously updating these values to track and compensate for any changes that may be introduced due to environmental drift. The stored minimum and maximum values are filtered based on the *Normalisation Beta* value after each rotation. This is the default, and recommended, setting for off-axis configurations.

5.2 Normalisation Default Values

The Minimum and Maximum values used for normalisation are reset after a Hall ATI. The reset values are stored in the *Default Min/Max* registers and copied into the tracked Min/Max registers after an ATI event.

5.3 Factory Calibration

In 'Auto' normalisation mode, normalisation is only applied once valid (non-zero) minimum and maximum values have been measured. However, after start-up, these values are only seeded after completing a few full rotations. As a result, the first rotation after start-up may have lower accuracy than expected. In order to improve the accuracy of the Hall-rotation sensing from power-on, initial minimum and maximum normalisation values can be written to the IQS325. This requires a factory calibration procedure to measure, read, and store the nominal normalisation parameters. On all subsequent starts, these values can then be written to the IQS325.

The following factory calibration procedure is recommended:

- > Initialise the IQS325 over I²C as normal, with the desired settings.
- > Perform an ATI by setting the *Hall ATI* bit in the *System Commands* register. This resets the minimum and maximum values to 0.
- > Wait for ATI to complete by waiting for the next communications (RDY) window.
- > Rotate the magnet by at least 540° (1.5 revolutions).
- > Read and store the values of the *Normalisation Minimum/Maximum* registers.



This calibration sequence only needs to be done once, during production. Once these compensation values are known, they can be written to the IQS325 every time on start-up.

The following procedure is then recommended for normal operation:

- > Initialise the IQS325 over I²C as normal, with the desired settings.
- > Write the stored min/max values to the *Default Minimum/Maximum* registers.
- > Perform an ATI by setting the *Hall ATI* bit in the *System Commands* register. This triggers the IQS325 to copy the Default Min/Max values into the working registers.



6 ProxFusion® Channel

The IQS325 features a ProxFusion® sensing channel (Channel 0, or “CH0”) that uses Azoteq’s patented on-chip ProxFusion® module to measure and process relative changes in capacitive and inductive sensors.

The channel provides two primary Event types – *Button* and *Movement* events. The Button event attempts to track slow changes and long-term activations, whereas the Movement event detects smaller, fast changes. Each of these events stores their own reference and delta values.

The Movement event integrates with the Hall-Rotation UI, providing activation triggers for starting and stopping freewheeling.

6.1 Sensing Modes

The ProxFusion® channel supports the following sensing modes:

- > Self-capacitive sensing
- > Resonated inductive sensing

The sensing mode can be modified in the *CH0 Sensor Settings 0* register.

Please refer to the following [application notes](#) for more information:

- > AZD004: Overview of Azoteq’s ProxFusion® Sensing
- > AZD115: Design Guidelines for Inductive Sensing
- > AZD125: Design Guidelines for Capacitive Touch Sensing
- > AZD144: Inductive Freewheel and Haptics Design Guide (available upon request)

6.2 Counts

The ProxFusion® module reports a capacitance or inductance measurement as a relative, unitless value referred to as “Raw Counts”. These raw counts are related to the number of charge transfer cycles necessary to charge an internal sampling capacitor and are typically inversely proportional to the signal measured on the external sensor.

6.2.1 Counts Linearisation

The IQS325 does not directly use the “Raw Counts” obtained from the sensing module, but uses “Linearised Counts”, which is calculated as

$$\text{Linearised Counts} = \frac{3276750}{\text{Raw Counts}} \quad (3)$$

All references to “Counts” in this datasheet, and in the I²C memory map, use these Linearised Counts values.

After linearisation, counts are filtered using a low-pass IIR filter to reduce the high-frequency noise in the measurement. The response of the filter can be adjusted with the *Counts Filter Beta* value in the *Filter Betas* registers. Higher beta values result in a slower filter response, with less noise on the channel.



6.3 Button Event Detection

The Button Event attempts to emulate the behaviour of a typical button, which stays in activation for as long as it is pressed.

6.3.1 Long-Term Average

Button events are detected by comparing the filtered counts value to a reference value, known as the Long-Term Average (LTA). While the channel is not in activation, the LTA is slowly updated to track changes in the environment using a low-pass filter.

The difference between the filtered counts and the LTA is stored as the *Delta* value.

$$\text{Delta} = \text{LTA} - \text{Counts} \tag{4}$$

The delta is used to detect user interaction by comparing it to the *Button Threshold*. The channel enters the active state when the delta exceeds the threshold, and the *Button Active* bit in the *Button Flags* register will be set.

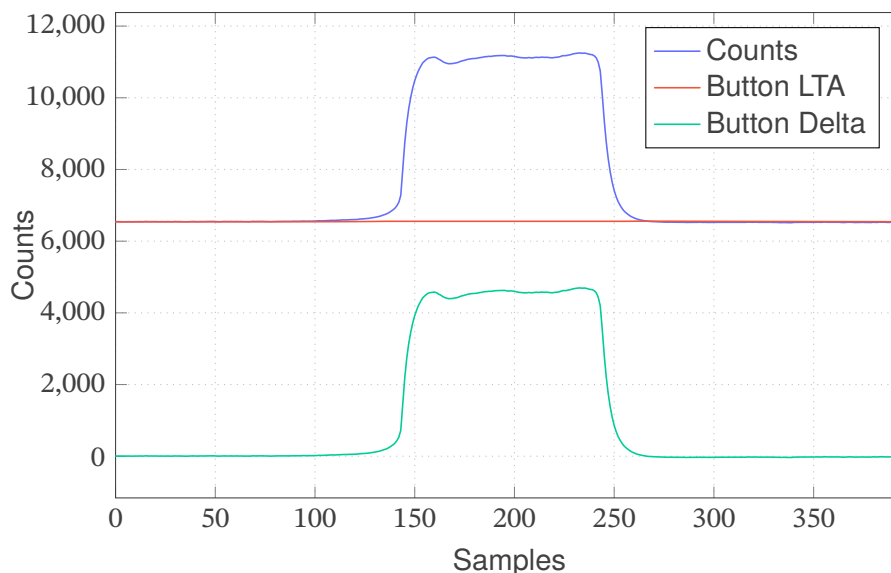

Figure 6.1: Button UI Activation

The LTA is then halted (kept constant) while the Button event is active, or while the delta exceeds the *LTA Halt Threshold*, as shown in Figure 6.1. The LTA Halt Threshold can typically be made smaller than the Button Threshold. This may help increase the sensitivity of the event detection during slower activations, preventing the LTA from drifting during user interaction.

The response of the LTA filter is controlled by the various *LTA Beta* values. The *LTA Beta* value sets the response of the filter during High-Accuracy and Normal power modes, whereas the *Low Power LTA Beta* is used during Low and Ultra-Low power modes. The Low Power Beta value should be set to a *larger* value than the Normal Beta value to maintain adequate sensitivity at lower sampling rates.



6.3.2 Direction

In most cases, negative delta values are disregarded as they suggest an unexpected decrease in signal. If a negative delta value exceeds the *Fast LTA Bound* threshold, the LTA will be updated using the *Fast LTA Beta* filter. This behaviour can be disabled by setting the *Bi-Directional* bit, or the sign of the delta can be inverted by setting the *Inverse* bit in the *CH0 UI Settings* register.

6.3.3 LTA Reseeding

The reseed function of the device will replace the filtered counts and the long-term average value of the channel with the latest sampled counts value to reset the environmental reference of the channel. This may be necessary in certain instances when the Button event gets incorrectly stuck in an activation. Detection of stuck states is controlled by the *Button Timeout* parameter. If the Button event remains active for this timeout duration, the LTA is reseeded automatically. This behaviour can be disabled by setting the timeout parameter to 0.

A *Reseed* command can also be given manually by setting the corresponding bit in *System Commands*.

6.4 Movement Event Detection

The Movement Event detects small, rapid changes or movements on the ProxFusion channel. This may be used to trigger freewheeling in Hall-rotation applications, or as a simple wake-up event, triggered as the user approaches the sensor.

6.4.1 Long-Term Average

The Movement event tracks its own LTA and delta values, separately from the Button event. In contrast to the Button event, the Movement event does not halt its LTA. Instead, it filters using the regular LTA Beta value while not in activation, and filters with the Fast LTA Beta while the event is active (while the delta is larger than the *Movement Threshold*).

The purpose of this is to track increases in the rate of change of counts. This typically occurs as a user is approaching or releasing a proximity sensor. Outside of activations, the LTA is updated slowly to maximise sensitivity to changes in counts. As soon as the delta exceeds the threshold, the fast LTA is used to exit the movement event as quickly as possible, to be ready to detect the next change in counts. This allows for detection of quick flicks typically performed when attempting to activate freewheeling on scroll wheels. An example of the Movement's response to a flick is shown in Figure 6.2.

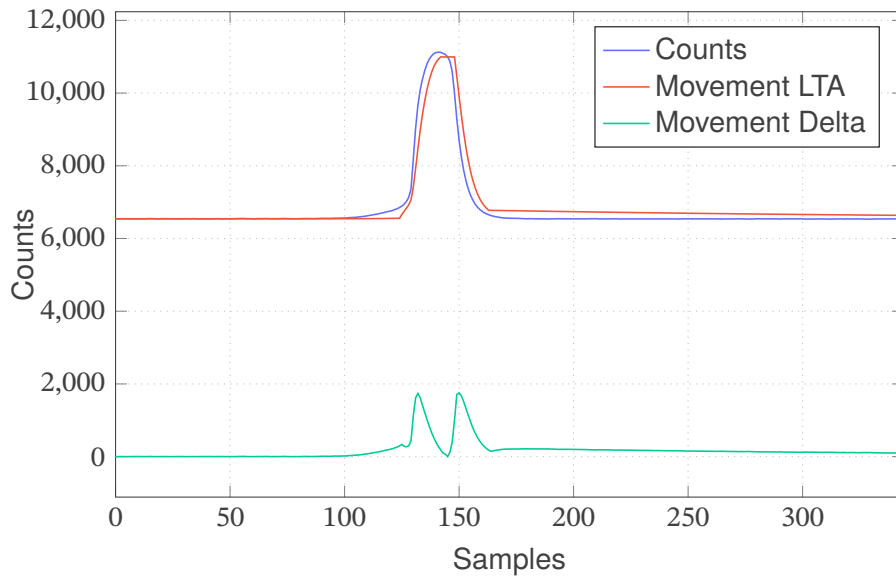

Figure 6.2: Movement UI Activation

6.4.2 Movement Flags

The primary outputs of the Movement Event are the *Movement Entered* and *Movement Exited* flags in the *Movement Flags* registers. The Movement Entered flag is set while the delta exceeds the threshold with a positive sign, and indicates that a user approached the sensor, or entered touch. The Movement Exited flag is set while the delta exceeds the threshold with a negative sign, indicating that the user released the sensor. These flags can be flipped by setting the *Inverse* bit.

Note that the Movement event is not affected by the *Bi-Directional* setting.

During slower movements, the same flag may be set multiple times consecutively. For example, an Enter event may occur repeatedly as the user approaches the sensor.

6.5 Dormancy

The touch dormancy flag will be set if the dormancy timeout event occurs after no touch input is received for the period defined in the *Dormancy Timeout* parameter. The IQS325 may only enter lower power states once the dormancy flag is set.

6.6 Automatic Tuning Implementation

The ATI is a sophisticated technology implemented in ProxFusion[®] devices to allow optimal performance of the devices for a wide range of sensing electrode designs, without modification to external components.

The ATI functions by using the *Base* and *Target* parameters to calculate appropriate *Divider* and *Compensation* values to achieve an LTA approximately equal to the ATI target value. Note that the base and target values are specified in terms of Linearised Counts, and the base value should always be larger than the target. Typically, a base value of 10000 to 30000 can be used, while a target value between 3500 and 10000 is recommended.

If the ATI algorithm cannot achieve a counts value within the ATI Band, the IQS325 will set the channel's ATI Error flag.



The Coarse Gain parameter in the *CHO Dividers* register can be tuned in the GUI. The ATI will then adjust the Fine Divider parameter until the counts reach the base value. The Coarse Gain should be manually adjusted at design time until the Fine Divider reaches a value between '4' and '14' after ATI. It can then be fixed across production.

6.7 Automatic Re-ATI

One of the most important features of the automatic Re-ATI functionality of the IQS325 is that it allows easy and fast recovery from an incorrect ATI, such as when performing ATI during user interaction with the sensor. It is always recommended to have the automatic Re-ATI functionality enabled. When a Re-ATI is performed on the IQS325, the *ATI Event* status bit will be set momentarily to indicate that this has occurred.

An automatic Re-ATI operation is performed when the reference of a channel drifts outside the acceptable range around the ATI Target, which is defined by the *ATI Band* parameter. Automatic Re-ATI is also triggered on ATI Error states.

6.8 Debouncing and Hysteresis

Each of the Button and Movement events provides two mechanisms to prevent jitter: debouncing and hysteresis.

Debouncing occurs when the Button or Movement delta initially crosses the threshold. It forces the IQS325 to perform a number of quick measurements (at High-Accuracy report rate), checking that all measurements exceed the threshold. The event's *Debouncing* flag is set as long as debouncing is active. Once debouncing is complete, the event's *Active* flag is set.

The number of high-frequency measurements to execute can be configured independently for entering or exiting the event's active state in the *Debounce* register. Setting the debounce values to '0' or '1' will disable debouncing.

Hysteresis allows the channel to use different enter and exit thresholds for an event. Once the event has entered the active state by exceeding the normal threshold value, the exit threshold is calculated as

$$\text{Exit Threshold} = \text{Threshold} \times \left(1 - \frac{\text{Hysteresis Value}}{256}\right) \quad (5)$$

For example, with a Button threshold of 100 counts, and a hysteresis value of 50, the Button event will enter the Active state when the delta exceeds 100 counts, and will exit the Active state when the delta drops down to $100 \times (1 - 50/256) = 80$ counts.

6.9 Button GPIO

The IQS325 has two pins available to be used as a Button output indicator. Configuring such a pin sets it to provide an open-drain active-low signal that echoes the state of the Button Event of the ProxFusion channel. As long as the Button Event is active (delta is above the threshold), the pin is pulled low, until the Prox sensor is released or the Button timeout is reached. A pull-up resistor between the pin and VDD is required.

The two available pins are:



- > MCLR/BOUT: Enabling the Button output on the MCLR pin disables the MCLR functionality, and sets the pin to output mode. This may be used in applications where a MCLR pin is not required to be able to reset the device. For example, the IQS325 may be soft reset via an I²C command.
- > SDA/BOUT: This setting disables the IQS325's I²C peripheral, and uses the SDA pin as the Button output. This setting only takes effect when the IQS325 is placed in standalone mode. The I²C peripheral may only be re-enabled by resetting the device using the MCLR pin.



7 Freewheel UI

The freewheeling UI of the IQS325 allows the device to continue emulating rotational input when no physical rotation is detected by the Hall-effect sensor. Freewheeling integrates the Hall-rotation sensing and the ProxFusion channel to detect deliberate flicks of a scroll wheel. On a flick, the Freewheel UI measures the rotational speed of the magnet, then continuously increments the Processed Angle at the measured rotational speed, as though the magnet was freely spinning. This speed will eventually decay until the freewheeling event has ended.

A freewheeling event can occur when the freewheeling UI is enabled, and a Movement Exit event occurs while the rotational speed of the physical input is greater than the *Freewheel Start Speed*. Freewheeling continues until the freewheeling speed decays below the value defined in the *Freewheel Stop Speed* parameter.

The movement release delta required to start a freewheeling event is defined by the *Forward Movement Threshold* and *Reverse Movement Threshold* parameters. These parameters are used to set different touch release sensitivity values for freewheeling in different directions.

Freewheeling can be manually stopped during the emulated rotation by triggering a touch event. The *Movement Stop Threshold* parameter will determine the delta of the Movement event required to stop freewheeling.

7.1 Effects of Freewheel Parameters

A simplified equation of the freewheeling angular velocity over time is displayed in Equation (6).

$$\omega_{n+1} = \omega_n - \frac{\text{Friction} + (\text{Damping} \times \omega_n)}{\text{Inertia}} \quad (6)$$

Figure 7.1 displays the change in angular velocity as the freewheeling friction parameter changes. Freewheeling damping remains constant with a value of 5000, and freewheeling inertia remains constant at 150.

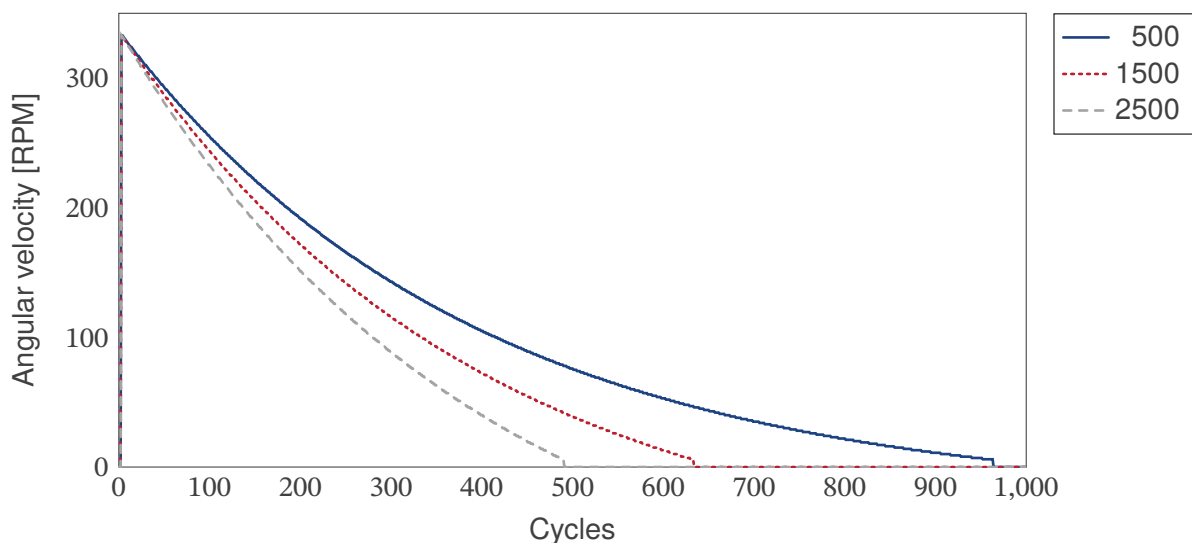

Figure 7.1: Freewheel Response as Friction Changes



Figure 7.2 displays the change in angular velocity as the freewheeling damping parameter changes. Freewheeling friction remains constant with a value of 1000, and freewheeling inertia remains constant at 150.

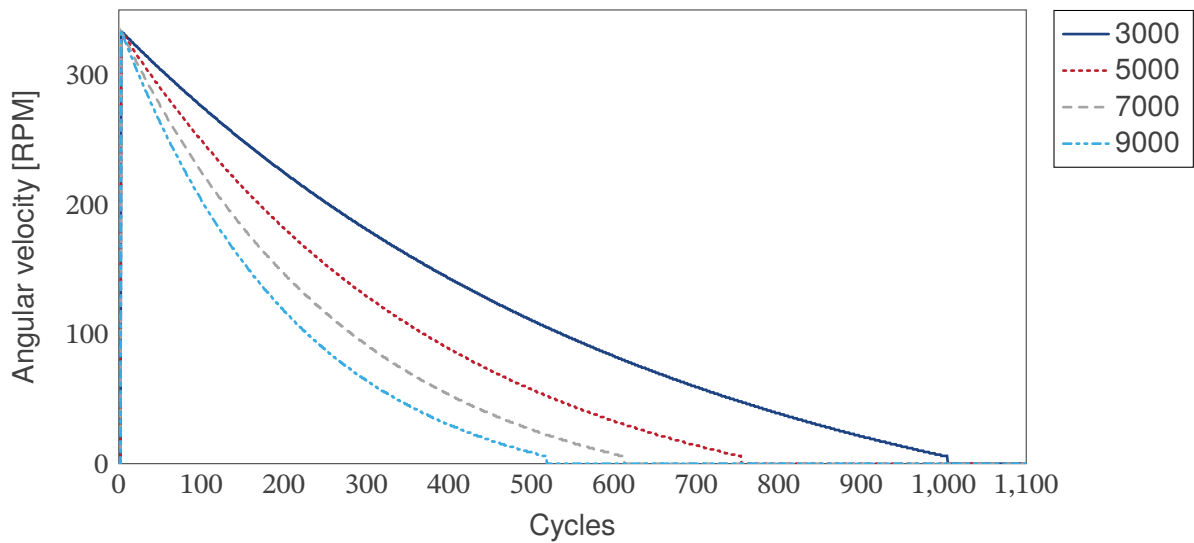

Figure 7.2: Freewheel Response as Damping Changes

Figure 7.3 displays the change in angular velocity as the freewheeling inertia parameter changes. Freewheeling damping remains constant with a value of 5000, and freewheeling friction remains constant at 1000.

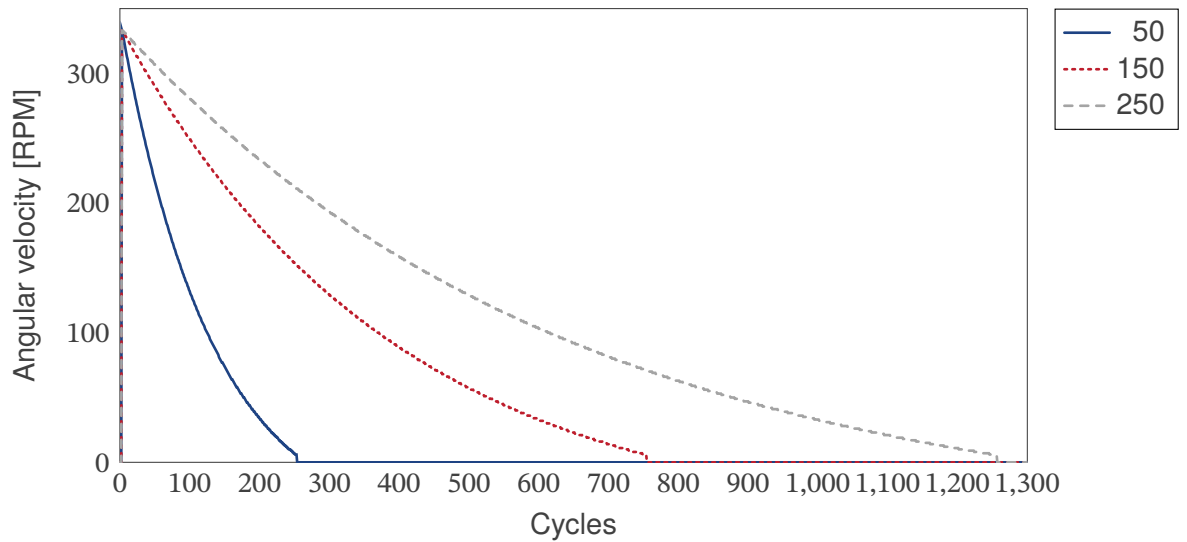

Figure 7.3: Freewheeling Response as Inertia Changes



8 Power Options

8.1 Power Modes

The IQS325 offers 5 power modes:

> High-Accuracy (HA)

- Highest current consumption
- High-accuracy mode is always entered during debouncing on the ProxFusion channel.
- When in automatic power mode, high-accuracy mode is entered when:
 - * The *Interval* value has changed.
 - * A freewheeling event occurs with the *Force High-Accuracy Freewheeling* option enabled in *Rotation UI Settings*.

> Normal Power Mode (NP)

- The default operating power mode
- When in automatic power mode, normal power mode is entered when:
 - * Exiting high-accuracy mode after the high-accuracy timeout.
 - * Touch or movement event on the ProxFusion channel.

> Low Power Mode (LP)

- Typically configured with a slower report rate to reduce current consumption.
- When in automatic power mode, low power mode is entered when the two following conditions are met:
 - * Hall *Stationary* flag is set.
 - * ProxFusion *Dormant* flag is set.

> Ultra-Low Power Mode (ULP)

- Recommended being configured for the slowest report rate.
- In automatic power mode, the device will enter ULP mode after the *ULP Timeout* Event occurs. The ULP timer is started when the device enters LP mode.
- By default, ULP mode still samples both the Hall plates and the ProxFusion channel every cycle. ULP mode can instead be configured to use AutoProx, which only samples a single channel each cycle to further reduce current consumption.

> Halt Mode

- Is entered and exited by an I²C command.
- Places device in standby mode.
- No analog sampling events occur during halt mode.
- To exit halt mode the master device must open a forced communications window (Refer to Section 10.11.2) and select an alternative power mode for the IQS325.

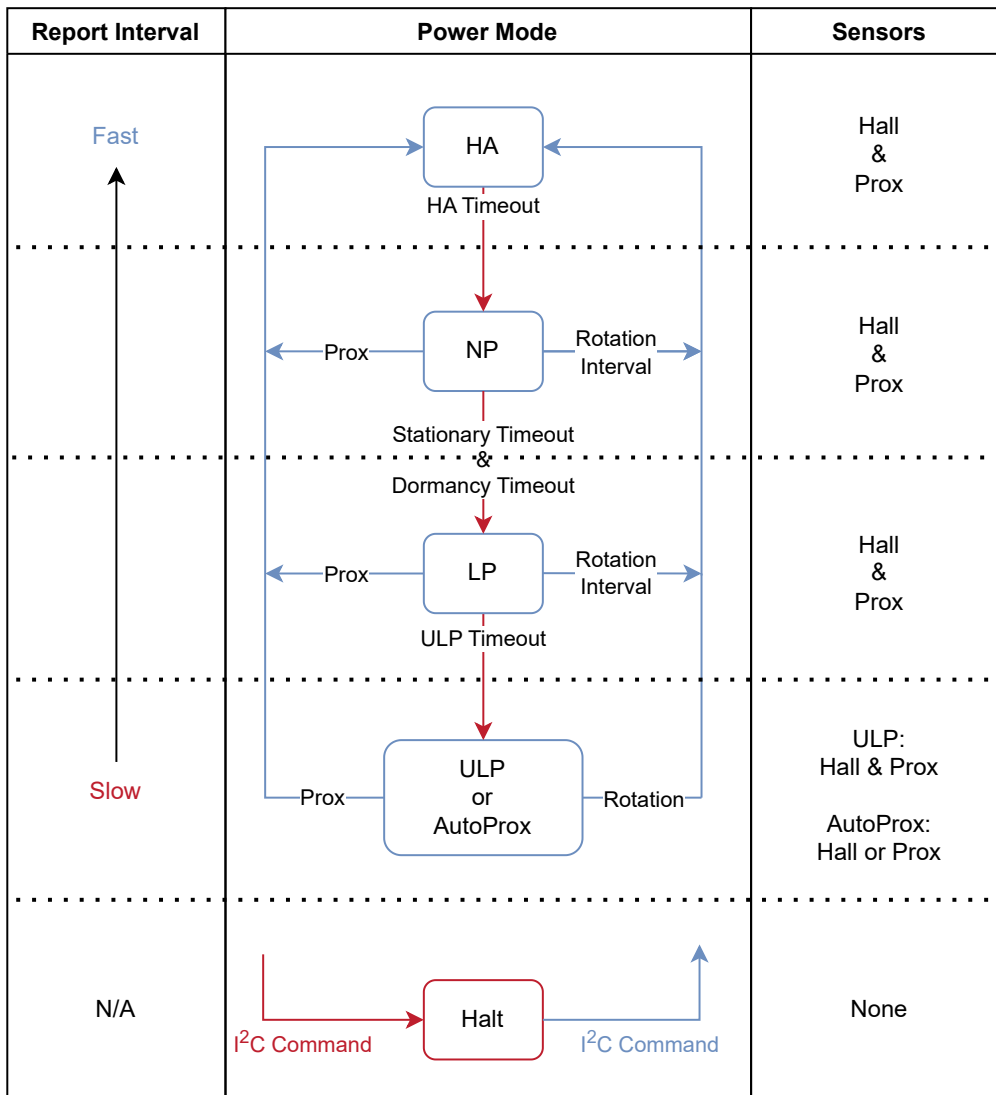

Figure 8.1: Power Modes

8.2 AutoProx

The IQS325 can be configured to use AutoProx when entering ULP Mode to further reduce current consumption. AutoProx is a feature that allows the IC to sample a single channel and perform basic limit checks on the counts, without running any power-intensive UIs or calculations. The channel then acts as a basic wake-up sensor. If the counts exceed the configured limit, the IQS325 will wake up and perform a full measurement and processing cycle.

AutoProx is enabled by setting the *AutoProx Enable* bit in the *Autoprox Settings* register. The wake-up channel can be selected as either the ProxFusion channel, or one of the Hall channels. This allows the IC to wake up on either a touch event, or when the magnet is rotated.

Note that AutoProx then replaces the regular ULP mode, and samples at the same rate as the ULP report rate. AutoProx should only be used with the Power Mode set to 'Auto'.



8.2.1 AutoProx Limits

The AutoProx counts limit is set in the [AutoProx Threshold](#) register. Typical threshold values lie between 100 and 500 counts.

For the ProxFusion channel, the AutoProx threshold may be set to the same value as the [ProxFusion LTA Halt Threshold](#).

For the Hall channels, the threshold can be chosen based on the size of the swing on the Hall channels, as well as the interval size. Ideally, the IQS325 should wake up within half an interval of rotation. For example, with 24 intervals (15° per interval), the device should wake up after a rotation of 7.5° or less. If the Hall Gain is adjusted to get ±4000 counts of swing on the Hall channels, the maximum allowed AutoProx limit is

$$\text{Max Threshold} = 4000 \sin(7.5^\circ) = 522.$$

Note that certain invalid AutoProx Threshold configurations may result in an *AutoProx Error*, which is indicated in the [Device Status](#) register. At design time, it should be ensured that the chosen threshold does not cause this error flag to be set.

Note that if the AutoProx error flag is set during runtime, the IQS325 will fall back to performing regular measurements rather than AutoProx conversions while in ULP. Please contact Azoteq for more information.

8.2.2 AutoProx Update Rate

After a certain number of AutoProx measurements, the IQS325 will automatically wake up and sample all channels for a single cycle. This is configured in the [Autoprox Settings](#) register, and can be configured to wake the device up periodically after 4, 8, 16, or 32 AutoProx measurements.



9 Additional Features

9.1 Debug and Display Software (GUI)

The Azoteq IQS325 GUI can be utilised to configure the optimal settings required for a specific hardware setup or application. The device performance can be easily monitored and evaluated in the graphical environment until the optimal device configuration is obtained.

Once the IQS325 is configured in the GUI as desired, a C header file (.h file) can be exported that stores the values of all the read-write registers of the IQS325. The .h file displays the start address of each block of data, with each address containing one byte. An example of the .h file exported by the GUI is shown below.

```
/* Change the System Control Settings */  
/* Memory Map Position 0x1000 - 0x1011 */  
#define AUTO_CLEAR_SETTINGS          0x00  
#define SETTINGS_0                   0xC4  
...
```

9.2 Main Oscillator

The main oscillator frequency can be configured for 14 MHz or 18 MHz. This is configured in the [System Settings](#) register. The lower-frequency configuration reduces the requirements on VDD, as shown in Section 3.3.

The higher-frequency configuration allows for larger amplification of the Hall plate signals, reducing noise in situations with low magnetic fields. This can be achieved by setting the [Hall Plate Bias](#) register to a higher value. The following table provides recommended values:

Table 9.1: Recommended Hall Bias Values for Different F_{OSC} Values

F_{OSC} [MHz]	Hall Bias Value
14	30
18	37

9.3 Watchdog Timer (WDT)

A software watchdog timer is implemented to improve system reliability. The watchdog timer is reset at the start of the main loop before any measurements take place. If the timer expires, the device is reset, performing a soft reboot. The *Watchdog Period* in the [System Settings](#) register determines the period of the timer in milliseconds before the device will reset.

Note: Ensure that the watchdog timeout period is greater than the I²C timeout period.

9.4 Reset

9.4.1 Reset Indication

After a reset, the *Show Reset* bit in the [Device Status](#) register will be set by the system to indicate that the reset event occurred. This device reset bit will clear when the master sets the *Ack Reset* bit in the [System Commands](#) register. If the Show Reset bit becomes set again, the master will know a reset has occurred and can react appropriately.



9.4.2 Software Reset

The IQS325 can be reset by means of an I²C command by setting the *Soft Reset* bit in the *System Commands* register.



10 I²C Interface

10.1 I²C Module Specification

The device features a standard two-wire I²C interface, complemented by a RDY (ready interrupt) line, supporting a maximum bit rate of up to 1 Mbit/s. The memory structures accessible over the I²C interface are byte-addressable with 16-bit address values. 16-bit or 32-bit values are packed with little-endian byte order and are stored in word-aligned addresses.

- > Standard two-wire interface with RDY interrupt line
- > *Fast-Mode Plus* I²C with up to 1 Mbit/s bit rate
- > 7-bit device address
- > 16-bit little-endian register addressing
- > One data byte stored per register address

10.2 I²C Address

The IQS325 has a default I²C address of 0x54 (0b1010100). The full 8-bit address byte will thus be 0xA8 (write) or 0xA9 (read).

Additional I²C address options may be available. Please refer to Section 12 (Ordering Information) for available addresses, or contact Azoteq for custom addresses (subject to MOQ).

10.2.1 Reserved I²C Address

When communicating with the IQS325, it will acknowledge (ACK) communication attempts made to an additional address derived from its slave address. This derived address is obtained by flipping the least significant bit of the slave address.

For example, with the default slave address of 0x54, the derived address would be 0x55 (0b1010101), obtained by changing the LSB from '0' to '1'. This derived address is reserved for internal use and should not be used. Even though the device will acknowledge communication attempts to this address, it will not function as normal and should therefore be avoided.

10.3 I³C Compatibility

This device is not compatible with an I³C bus due to clock stretching allowed for data retrieval.

10.4 Memory Map Addressing

All memory locations are 16-bit addressable in little-endian byte order.

10.5 Memory Map Data

Each 16-bit memory map address stores a single byte (8 bits), making the memory map byte-addressable. Since the data is packed in a little-endian sequence, a 16-bit value starting at, for example, address 0x1014 will have its least significant byte at address 0x1014 and its most significant byte at address 0x1015.



10.6 RDY/IRQ

The IQS325 has an open-drain active low RDY signal to inform the master that updated data is available. The IQS325 will pull the RDY line low to indicate that it has opened a communications window, or “RDY window”, for the master to read the new updated data. While the master can communicate with the device at any time according to the *Force Comms Method*, it is recommended to use the RDY signal for optimal power consumption. Integrating the RDY signal as an interrupt input allows the master MCU to read and write data efficiently.

The device provides both streaming and event modes. In streaming mode, the RDY line toggles continuously with each sensing cycle, whereas in event mode, the RDY toggles only when specific events occur. The types of events that trigger the RDY window are configurable in the *Event Mask* register.

10.7 Read and Write Operations

10.7.1 I²C Read From Specific Address

A typical read operation is displayed in Figure 10.1. The master device waits for the RDY line of the IQS325 to go low, indicating the availability of new data and an available communication window. Once the RDY interrupt is triggered, the master initiates communication by sending a start condition followed by the device address and a write command. The IQS325 responds with an acknowledgement, after which the master device will transmit two bytes defining the register address. The master then sends a repeated start condition, followed by the device address with a read command. The IQS325 transmits data from the requested address and will continue to do so while the master acknowledges each byte. The read operation is ended when the master does not acknowledge the last byte received and produces a stop condition.

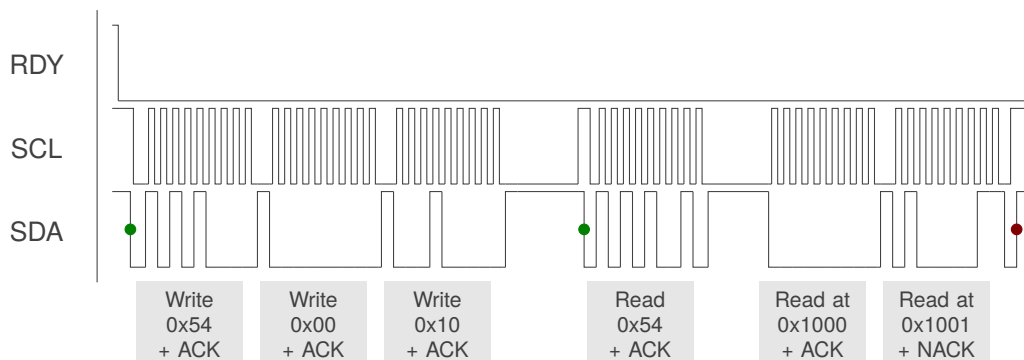

Figure 10.1: I²C Read Example — Read Status Registers 0x1000 and 0x1001

10.7.2 I²C Write To Specific Address

The write operation is displayed in Figure 10.2. Similar to the read transaction, when the RDY interrupt is triggered, the master initiates communication by sending a start condition followed by the device address and a write command. The IQS325 responds with an acknowledgement, after which the master device transmits two bytes defining the register address. The slave acknowledges the register address bytes. The master may then write a series of bytes to the register address and the addresses that follow, with each byte being acknowledged by the slave. The write operation is ended when the master produces a stop condition.

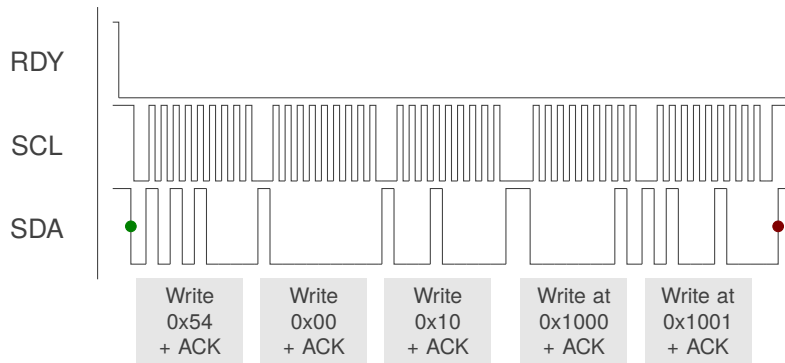

Figure 10.2: I²C Write Example — Write Two Bytes to Button Settings Registers 0x1000 and 0x1001

10.7.3 Modifying Bits Over I²C

When modifying individual bits in a register, it is recommended to read the register first, make the necessary modifications, and then write the updated value back to the IQS325 register to prevent unintentional bit changes.

For example, disabling the *Auto Power Mode* bit and choosing a specific *Power Mode* setting would involve:

- > Read the *Power Settings* Registers (0x100A) as illustrated in Figure 10.1.
- > Clear the *Auto Power Mode* bit using the bitwise AND operator. For example:

READ_VALUE AND 0xFB

- > Set the *Power Mode* setting by clearing the bit field using a bitwise AND operation, then setting the bit field value with an OR operation. For example, to set the *Power Mode* to 'Normal':

(READ_VALUE AND 0xF8) OR 0x01

- > Write the new values back over I²C, as shown in Figure 10.2.

Read-modify-write transactions should be done in a single communication window, using I²C restart conditions. Please refer to Section 10.9 for more information regarding multiple I²C transactions in a single communication window.

10.8 I²C Timeout

If the communication window is not serviced within the *I²C Timeout* period (in milliseconds), the session is ended (RDY goes HIGH), and processing continues as normal. This allows the system to continue and keep reference values up to date even if the master is not responsive. However, the corresponding data will be lost, so this should be avoided. The default I²C timeout period is set to 250 ms.



10.9 Terminate Communication

With the *I²C Stop Ends Comms Window* setting enabled in the *I²C Settings* register, a standard I²C STOP ends the current communication window. If multiple I²C transactions need to be done, then they should be strung together using repeated-start conditions instead of giving a STOP. Allowing an I²C STOP to terminate the communication window is the recommended method, as illustrated in Figures 10.1 and 10.2.

This behaviour can be temporarily disabled by clearing the *I²C Stop Ends Comms Window* setting. In this case, an I²C STOP will NOT terminate the communication window. Instead, the communication window can be closed manually, as desired, by setting the *I²C Stop Ends Comms Window* bit as the final I²C transaction, followed by a STOP.

10.10 Invalid Communications Return

The device will give an invalid communication response (0xEE) under the following conditions:

- > The host is trying to read from a memory map register that does not exist.
- > The host is trying to read from the device outside a communication window (while RDY is high).

10.11 Event Mode Communication

The device can be set up to bypass the communication window when no activity is sensed by setting the *Event Mode* bit in the *I²C Settings* register. This is usually enabled since the master does not need to be interrupted unnecessarily during every cycle if no activity occurs. The communication will resume (RDY will indicate available data) if an enabled event occurs. It is recommended that the RDY be placed on an interrupt-on-pin-change input on the master.

Event mode can only be entered if the following requirements are met:

- > Events must be serviced by reading from the *Event Flags* register to ensure all events flags are cleared, otherwise continuous reporting (RDY interrupts) will persist after every cycle, similar to streaming mode.
- > The *Show Reset* bit in the *Device Status* register has been cleared by setting the *Ack Reset* bit in *System Commands*.

10.11.1 Events

Numerous events can be individually enabled in the *Event Mask* register to trigger communication in Event Mode:

- > Power mode changes
- > ATI events
- > Touch/button events
- > Movement detection
- > Hall rotation event

10.11.2 Force Communication

In streaming mode, the IQS325 I²C will provide RDY windows at regular intervals specified by the relevant power mode report rate. This will provide the master with regular opportunities to perform I²C communication as necessary.



If the device is placed in Event Mode or Halt Mode, the IQS325 will not open RDY windows unless certain conditions are met. A new RDY window can be requested by writing 0xFF over I²C, followed by a stop condition. After a short delay, the IQS325 will pull the RDY line low and open a new communication window. This is shown in Figure 10.3.

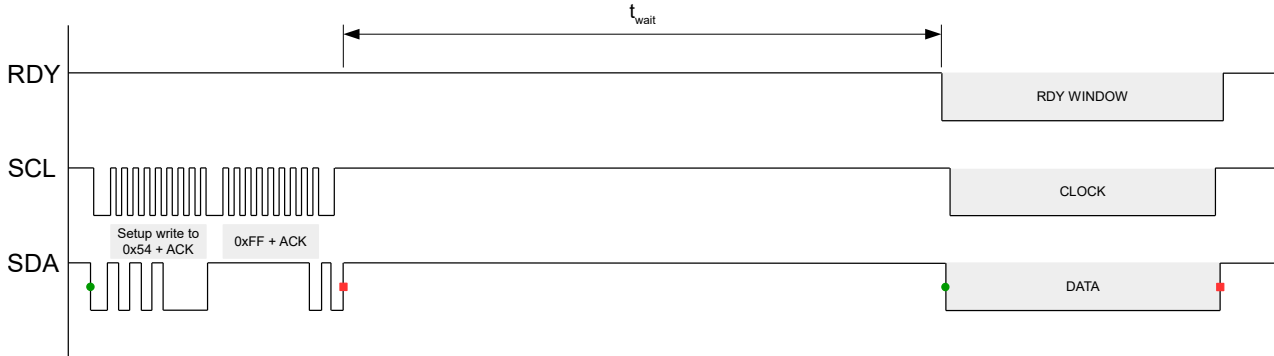

Figure 10.3: Force Comms Diagram

After a short delay, a new communication window will be made available, indicated by the RDY signal. The delay between the communication request and the opening of a RDY window (t_{wait}) is application-specific, but will typically be under 3 milliseconds.

10.12 Optimising I²C Streaming Transactions

The IQS325 provides the following two functions for reducing the overhead of performing I²C transactions to read data.

10.12.1 Customisable I²C Data Block

The IQS325 provides a block of 16 bytes, starting at address [0x208E](#), that can be configured to store any on-chip data in any order. This is done by configuring a list of “pointers” to specific read-only registers. The list of pointers is stored in the [I²C Data Allocation](#) registers, and are specified as offsets from 0x2000. For example, a pointer value of 0x0C resolves to address 0x200C (0x2000 + 0x0C), which is the [Raw Angle](#) measurement.

This customisable pointer list allows the I²C master to read any desired data (up to a total of 16 bytes) in a single read transaction, rather than performing multiple reads to different memory map addresses. The pointer list only needs to be configured once. The settings persist until the IQS325 is reset.

As an example, a typical application may need to read the [System Flags](#) register (to check the Show Reset flag), the [Event Flags](#) register (which is cleared on read), and the current [Interval](#) value. Typically, this data would need to be read in two consecutive read transactions; read two bytes from address 0x2000, and then read two bytes from address 0x2008. To reduce the I²C overhead, the [I²C Data Allocation](#) settings may be configured as follows:



Table 10.1: Custom I²C Data Example Setup

Data Allocation Register	Pointer Value
0x108E	0x00
0x108F	0x01
0x1090	0x08
0x1091	0x09

The master can now read the required data by reading four bytes from address [0x208E](#).

Table 10.2: Custom I²C Data Example

Read Address	Resolved Address
0x208E	0x2000: System Status
0x208F	0x2001: Event Flags
0x2090	0x2008: Interval (Least-significant byte)
0x2091	0x2009: Interval (Most-significant byte)

Note: It is always recommended to read the System Status and Event Flags registers in every RDY window.

10.12.2 Default Read Address

By default, if an I²C read transaction is started without first specifying a memory map address, the IQS325 will return data starting at address [0x2000](#). This default address may be changed to any value by writing the desired address to the [Default Read Address](#) register. On all subsequent communications windows, the default I²C read address is set to the value in the Default Read Address register.

As an example, the default read address may be changed to [0x208E](#), which is the custom I²C data section. In this way, an I²C master can read the exact data bytes required, without the overhead of writing any memory map addresses.



11 I²C Memory Map

11.1 Version Information (0x0000)

Table 11.1: Version Information Registers

Address	Length	Description	Value
Read-Only	No. Bytes	Version Information	
0x0000	2	Product Number	2904
0x0001			
0x0002	2	Major Version	1
0x0003			
0x0004	2	Minor Version	1
0x0005			

11.2 Settings Registers (0x1000)

Table 11.2: I²C Settings Registers

Address	Length	Description	Default	Notes
Read-Write	No. Bytes	System Control Settings		
0x1000	1	System Commands		Appendix A.1
0x1001	1	System Settings		Appendix A.2
0x1002	1	I ² C Settings		Appendix A.3
0x1003	1	Event Mask		Appendix A.4
0x1004	2	Startup I ² C Timeout		0 – 65535 ms
0x1005				
0x1006	2	I ² C Timeout		0 – 65535 ms
0x1007				
0x1008	2	Default Read Address		
0x1009				
0x100A	1	Power Settings		Appendix A.5
0x100B	1	AutoProx Settings		Appendix A.6
0x100C	2	HA Report Period		0 – 3000 ms
0x100D				
0x100E	2	NP Report Period		0 – 3000 ms
0x100F				
0x1010	2	LP Report Period		0 – 3000 ms
0x1011				
0x1012	2	ULP Report Period		0 – 3000 ms
0x1013				
0x1014	2	ULP Timeout		0 – 65535 ms
0x1015				
0x1016	2	AutoProx Threshold		
0x1017				
Read-Write	No. Bytes	Hall Sensor Settings		
0x1018	1	Hall Plate Selection		Appendix A.7
0x1019	1	Hall Plate Bias		Appendix A.8

Continued on next page...



Table 11.2: I²C Settings Registers (Continued)

0x101A	1	Hall Amplifier Gain	Appendix A.9
0x101B	1	Hall Initialisation Delay	Appendix A.10
0x101C	1	Hall Conversion Timings	Appendix A.11
0x101D	1	Hall Re-ATI Delay	
0x101E	2	Hall ATI Target	
0x101F			
0x1020	2	Hall ATI Band	
0x1021			
0x1022	2	Hall Multipliers	Appendix A.12
0x1023			
0x1024	2	Hall Plate Offset NW	
0x1025			
0x1026	2	Hall Plate Offset NE	
0x1027			
0x1028	2	Hall Plate Offset SE	
0x1029			
0x102A	2	Hall Plate Offset SW	
0x102B			
0x102C	2	Phase Angle Sin	
0x102D			
0x102E	2	Phase Angle Cos	
0x102F			
Read-Write	No. Bytes	Hall UI Settings	
0x1030	1	Rotation UI Settings	Appendix A.13
0x1031	1	Reserved	
0x1032	2	Wheel To Magnet Angle	Same unit as Processed Angle
0x1033			
0x1034	2	High Accuracy Timeout	0 – 65535 ms
0x1035			
0x1036	2	Stationary Timeout	0 – 65535 ms
0x1037			
0x1038	1	Angle Filter Beta	0 – 32
0x1039	1	Angle LP Filter Beta	0 – 32
0x103A	1	Auto Zero Beta	0 – 15
0x103B	1	Cordic Resolution	0 – 14
Read-Write	No. Bytes	Hall Interval Settings	
0x103C	2	Number Of Intervals	
0x103D			
0x103E	2	Interval Hysteresis	Same unit as Processed Angle
0x103F			
0x1040	2	Opposite Hysteresis	Same unit as Processed Angle
0x1041			

Continued on next page...



Table 11.2: I²C Settings Registers (Continued)

Read-Write	No. Bytes	Quadrature Settings	
0x1042	2	Quadrature Flank Delay	
0x1043			
0x1044	1	Quadrature Mode	Appendix A.14
0x1045	1	Quadrature Clock Divider	
Read-Write	No. Bytes	ProxFusion Sensor Settings	
0x1046	1	CH0 Sensor Settings 0	Appendix A.15
0x1047	1	CH0 Sensor Settings 1	Appendix A.16
0x1048	2	CH0 ATI Base	
0x1049			
0x104A	2	CH0 ATI Target	
0x104B			
0x104C	2	CH0 ATI Band	
0x104D			
0x104E	2	CH0 Dividers	Appendix A.17
0x104F			
0x1050	2	CH0 Compensation	
0x1051			
Read-Write	No. Bytes	ProxFusion UI Settings	
0x1052	1	CH0 UI Settings 0	Appendix A.18
0x1053	1	CH0 UI Settings 1	
0x1054	2	CH0 Touch Threshold	
0x1055			
0x1056	1	CH0 Button Debounce	Appendix A.19
0x1057	1	CH0 Button Hysteresis	
0x1058	2	CH0 Movement Threshold	
0x1059			
0x105A	1	CH0 Movement Debounce	Appendix A.20
0x105B	1	CH0 Movement Hysteresis	
0x105C	2	CH0 LTA Halt Threshold	
0x105D			
0x105E	2	CH0 Button Timeout	0 – 65535 ms
0x105D			
0x1060	2	CH0 Dormancy Timeout	0 – 65535 ms
0x1061			
0x1062	2	CH0 Re-ATI Delay	0 – 65535 ms
0x1063			
0x1064	2	CH0 LTA Halt Timeout	0 – 65535 ms
0x1065			
0x1066	1	CH0 Counts Filter Beta	0 – 15
0x1067	1	CH0 LTA Filter Beta	0 – 15
0x1068	1	CH0 LTA Filter Beta Fast	0 – 15
0x1069	1	CH0 LTA Filter Beta LP	0 – 15
0x106A	2	CH0 LTA Filter Fast Band	
0x106B			

Continued on next page...



Table 11.2: I²C Settings Registers (Continued)

Read-Write	No. Bytes	Button IO Settings	
0x106C	1	Button Output Settings 0	Appendix A.21
0x106D	1	Reserved	
Read-Write	No. Bytes	Freewheel Settings	
0x106E	1	Freewheel Speed Decay Beta	0 – 15
0x106F	1	Freewheel Speed Follow Beta	0 – 15
0x1070	2	Freewheel Friction	
0x1071			
0x1072	2	Freewheel Damping	
0x1073			
0x1074	2	Freewheel Inertia	
0x1075			
0x1076	2	Freewheel Min Speed	
0x1077			
0x1078	2	Freewheel Stop Speed	
0x1079			
0x107A	2	Freewheel Prox Stop Threshold	
0x107B			
0x107C	2	Freewheel Prox Forward Threshold	
0x107D			
0x107E	2	Freewheel Prox Reverse Threshold	
0x107F			
0x1080	2	Freewheel Magnet Movement Threshold	
0x1081			
0x1082	2	Freewheel Stationary Speed	
0x1083			
Read-Write	No. Bytes	Normalisation Settings	
0x1084	1	Hall Normalisation Beta	
0x1085	1	Hall Normalisation Mode	Appendix A.22
0x1086	2	Default Min A	
0x1087			
0x1088	2	Default Min B	
0x1089			
0x108A	2	Default Max A	
0x108B			
0x108C	2	Default Max B	
0x108D			
Read-Write	No. Bytes	I2C Data Allocation	
0x108E – 0x109D	16	I2C Data Allocation	Section 10.12.1



11.3 Data Registers (0x2000)

Table 11.3: I²C Data Registers

Address	Length	Description	Notes
Read-Only	No. Bytes	System Flags	
0x2000	1	System Status	Appendix A.23
0x2001	1	Events Flags	Appendix A.24
0x2002	1	Hall Flags	Appendix A.25
0x2003	1	Prox States	Appendix A.26
0x2004	1	Button Flags	Appendix A.27
0x2005	1	Movement Flags	Appendix A.28
Read-Only	No. Bytes	Hall Rotation Data	
0x2006	2	Interval Delta	
0x2007			
0x2008	2	Interval	
0x2009			
0x200A	2	Processed Angle	0 – 65536 → 0° – 360°
0x200B			
0x200C	2	Raw Angle	0 – 65536 → 0° – 360°
0x200D			
0x200E	2	Interval Upper Limit	Same unit as Processed Angle
0x200F			
0x2010	2	Interval Lower Limit	Same unit as Processed Angle
0x2011			
Read-Only	No. Bytes	ProxFusion Channel Data	
0x2012	2	CH0 Counts	
0x2013			
0x2014	2	CH0 Button LTA	
0x2015			
0x2016	2	CH0 Movement LTA	
0x2017			
0x2018	2	CH0 Button Delta	
0x2019			
0x201A	2	CH0 Movement Delta	
0x201B			
Read-Only	No. Bytes	Freewheel Data	
0x201C	2	Filtered Rotation Rate	
0x201D			
0x201E	2	Reserved	
0x201F			
0x2020	2	Freewheel Speed	
0x2021			
0x2022	2	Wheel Movement	Same unit as Processed Angle
0x2023			



Table 11.3: I²C Data Registers (Continued)

Read-Only	No. Bytes	Raw Sensor Counts	
0x2024	2	NW Raw Counts	
0x2025			
0x2026	2	NW INV Raw Counts	
0x2027			
0x2028	2	NE Raw Counts	
0x2029			
0x202A	2	NE INV Raw Counts	
0x202B			
0x202C	2	SE Raw Counts	
0x202D			
0x202E	2	SE INV Raw Counts	
0x202F			
0x2030	2	SW Raw Counts	
0x2031			
0x2032	2	SW INV Raw Counts	
0x2033			
0x2034	2	CH0 Raw Counts	
0x2035			
Read-Only	No. Bytes	Linearised Sensor Counts	
0x2036	2	NW Counts	
0x2037			
0x2038	2	NW Inverse	
0x2039			
0x203A	2	NE Counts	
0x203B			
0x203C	2	NE Inverse	
0x203D			
0x203E	2	SE Counts	
0x203F			
0x2040	2	SE Inverse	
0x2041			
0x2042	2	SW Counts	
0x2043			
0x2044	2	SW Inverse	
0x2045			
0x2046	2	CH0 Counts Unfiltered	
0x2047			
Read-Only	No. Bytes	Hall Field Data	
0x2048	2	NW Reference	
0x2049			
0x204A	2	NE Reference	
0x204B			
0x204C	2	SE Reference	
0x204D			



Table 11.3: I²C Data Registers (Continued)

0x204E	2	SW Reference	
0x204F			
0x2050	4	Field Buffer NW	
0x2051			
0x2052			
0x2053			
0x2054	4	Field Buffer NE	
0x2055			
0x2056			
0x2057			
0x2058	4	Field Buffer SE	
0x2059			
0x205A			
0x205B			
0x205C	4	Field Buffer SW	
0x205D			
0x205E			
0x205F			
0x2060	4	Field Differential A	
0x2061			
0x2062			
0x2063			
0x2064	4	Field Differential B	
0x2065			
0x2066			
0x2067			
Read-Only	No. Bytes	Hall Normalisation Data	
0x2068	4	Normalised Differential A	
0x2069			
0x206A			
0x206B			
0x206C	4	Normalised Differential B	
0x206D			
0x206E			
0x206F			
0x2070	2	Min A	
0x2071			
0x2072	2	Reserved	
0x2073			
0x2074	2	Min B	
0x2075			
0x2076	2	Reserved	
0x2077			
0x2078	2	Max A	
0x2079			



Table 11.3: I²C Data Registers (Continued)

0x207A	2	Reserved	
0x207B			
0x207C	2	Max B	
0x207D			
0x207E	2	Reserved	
0x207F			
0x2080	2	Local Min A	
0x2081			
0x2082	2	Local Min B	
0x2083			
0x2084	2	Local Max A	
0x2085			
0x2086	2	Local Max B	
0x2087			
Read-Only	No. Bytes	Custom I²C Data	
0x208E – 0x209D	16	Custom I ² C Data Bytes	Section 10.12.1



12 Ordering Information

12.1 Ordering Code

Table 12.1: Order Code Description

IQS325		zzz	ppb
IC NAME	IQS325		
CONFIGURATION	zzz =	001	Default configuration (I ² C enabled, address 0x54)
		002	Default configuration (I ² C enabled, address 0x44) ⁱ
		100	Reserved
PACKAGE TYPE	pp =	QF	QFN20 Package
		CS	WLCSP11 Package ^{i,ii}
BULK PACKAGING	b =	R	QFN20 Reel (2000 pcs/reel) WLCSP11 Reel (3000 pcs/reel)

12.2 Top Marking

12.2.1 QFN20 Package

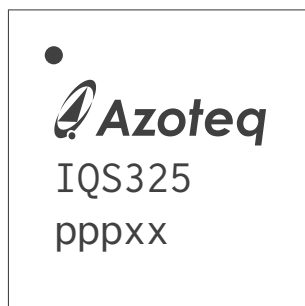

“IQS325” = Product Name
 “ppp” = Product Code
 “xx” = Batch Code

Figure 12.1: IQS325-QFN20 Package Top Marking

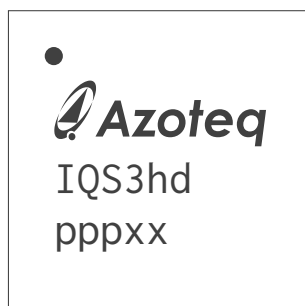

“IQS3hd” = Product Name
 “ppp” = Product Code
 “xx” = Batch Code

Figure 12.2: QFN20 Generic Package Top Marking

ⁱ Special order code: Subject to larger minimum order quantities, longer lead times, and are non-cancelable, non-returnable.

ⁱⁱ Hall plate positions are different for the QFN20 and WLCSP11 packages. Please refer to Section 2.5.



12.2.2 WLCSP11 Package

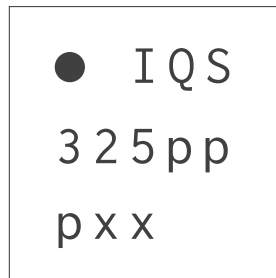

“IQS325” = Product Name

“ppp” = Product Code

“xx” = Batch Code

Figure 12.3: IQS325-WLCSP11 Package Top Marking



“IQS3hd” = Product Name

“ppp” = Product Code

“xx” = Batch Code

Figure 12.4: WLCSP11 Generic Package Top Marking



13 Package Information

13.1 QFN20 Package Outline

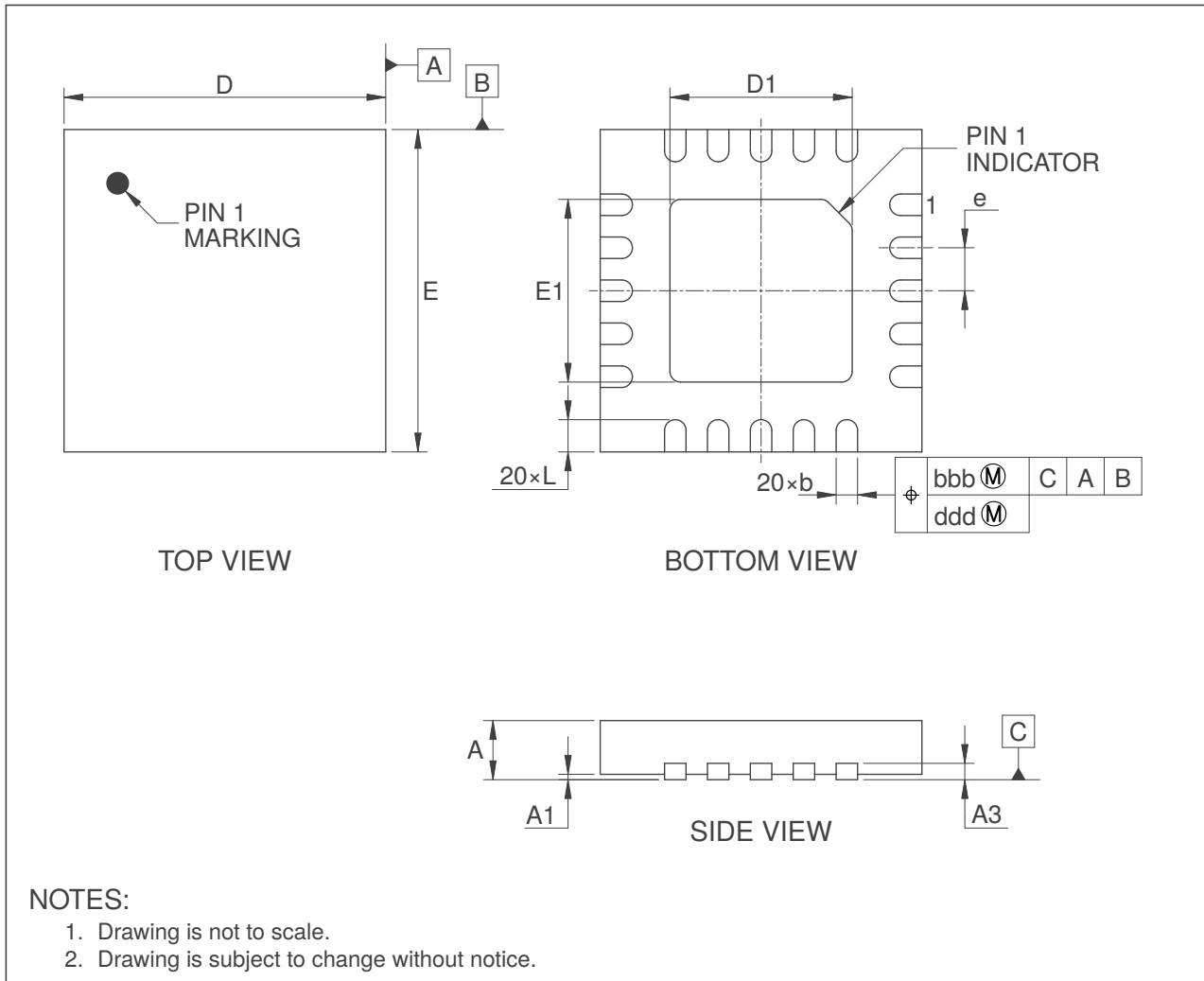

Figure 13.1: QFN20 Package Outline



Table 13.1: QFN20 Package Dimensions [mm]

Dimension	Millimeters		
	Min	Typ	Max
A	0.50	0.55	0.60
A1	0.00	0.02	0.05
A3	0.152 REF		
b	0.15	0.20	0.25
D	3.00 BSC		
E	3.00 BSC		
D1	1.60	1.70	1.80
E1	1.60	1.70	1.80
e	0.40 BSC		
L	0.25	0.30	0.35

Table 13.2: QFN20 Package Tolerances [mm]

Tolerance	Millimeters
bbb	0.07
ddd	0.05



13.3 WLCSP11 Package Outline

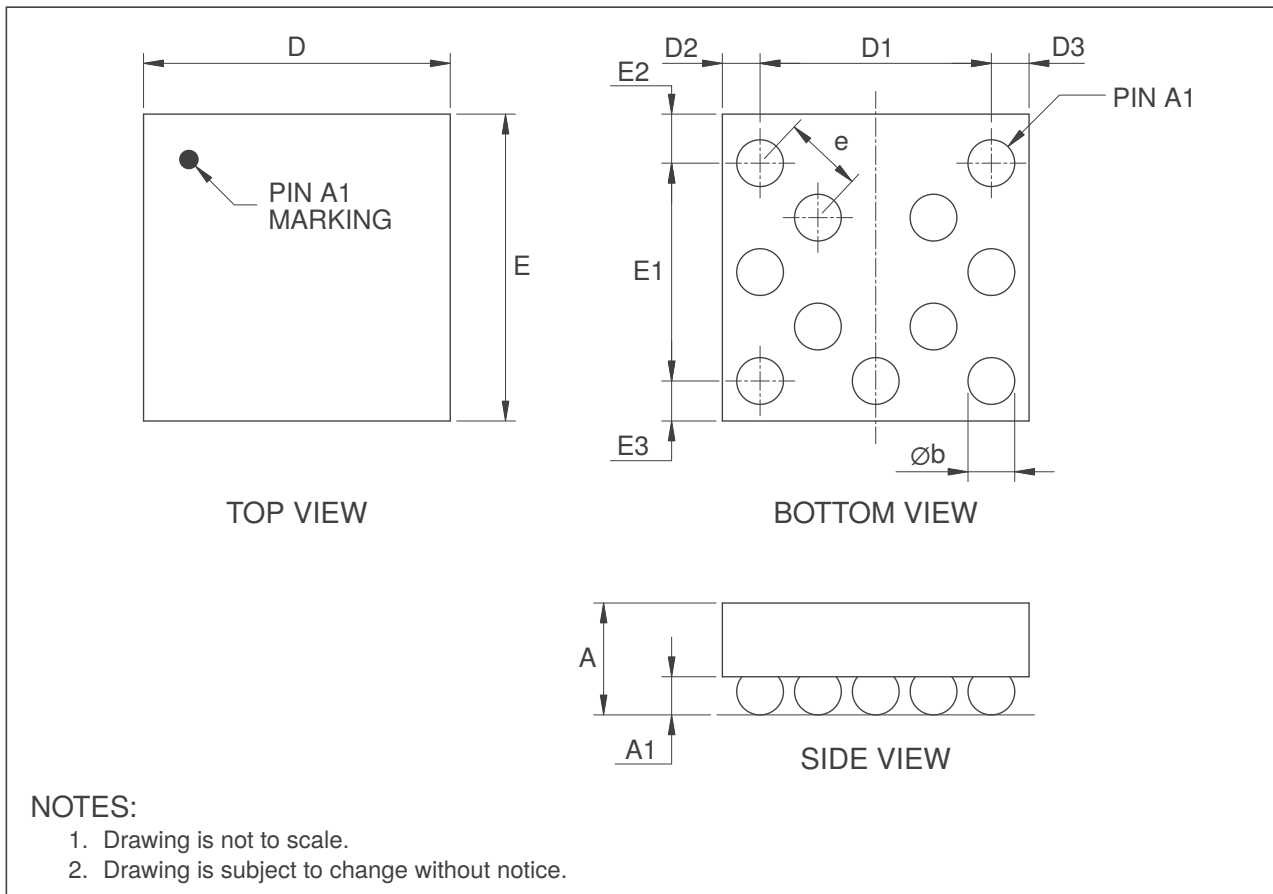

Figure 13.3: WLCSP11 Package Outline

Table 13.3: WLCSP11 Package Dimensions [mm]

Dimension	Millimeters		
	Min	Typ	Max
A	0.4482	0.4930	0.5378
A1	0.1512	0.1680	0.1848
b	0.1751	0.2060	0.2369
D	1.3250	1.3525	1.3800
E	1.3250	1.3525	1.3800
D1	1.0200 BSC		
D2	0.1663 BSC		
D3	0.1663 BSC		
E1	0.9600 BSC		
E2	0.2163 BSC		
E3	0.1763 BSC		
e	0.3500 REF		



13.4 WLCSP11 Recommended Footprint

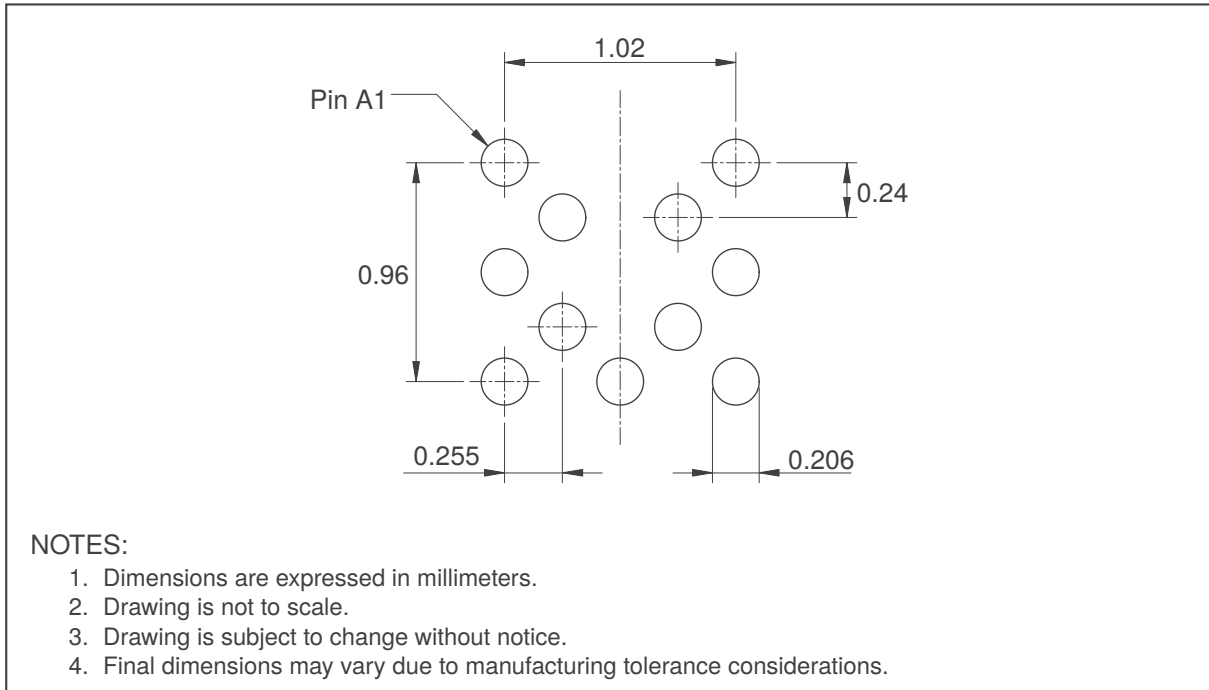

Figure 13.4: WLCSP11 Recommended Footprint



13.5 Tape and Reel Specifications

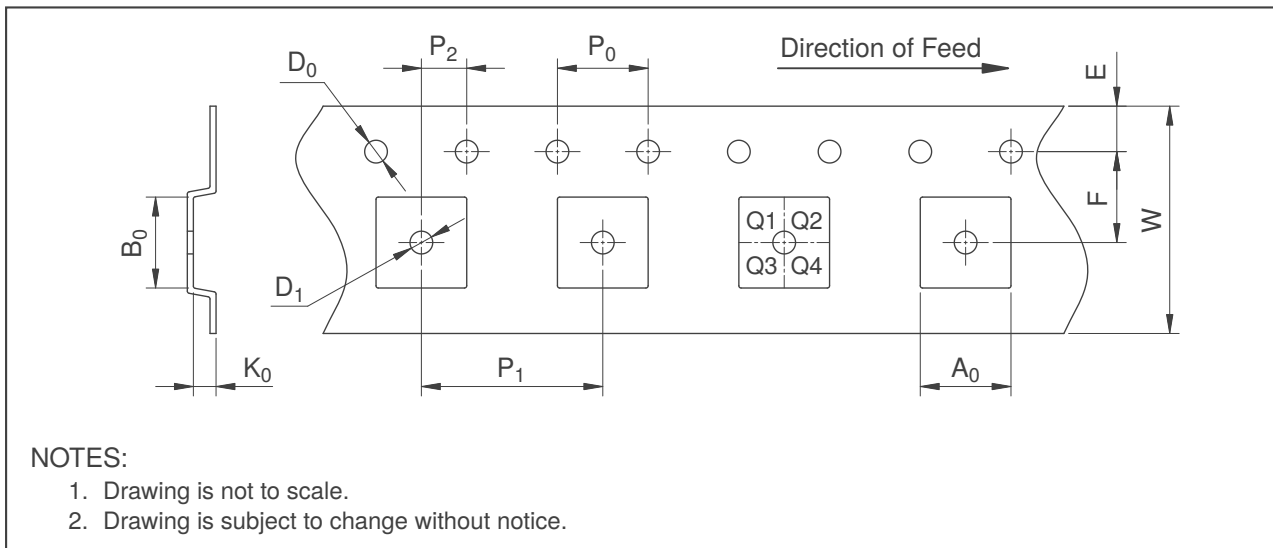

Figure 13.5: Carrier Tape Specification

Table 13.4: Carrier Tape Dimensions [mm]

Dimension	Package	
	QFN20	WLCSP11
A_0	3.30	1.46
B_0	3.30	1.46
K_0	0.75	0.70
D_0	1.50	1.50
D_1	1.55	0.25
E	1.75	1.75
F	5.50	3.50
P_0	4.00	4.00
P_1	8.00	4.00
P_2	2.00	2.00
W	12.00	8.00
Pin 1 Quadrant	Q2	Q1

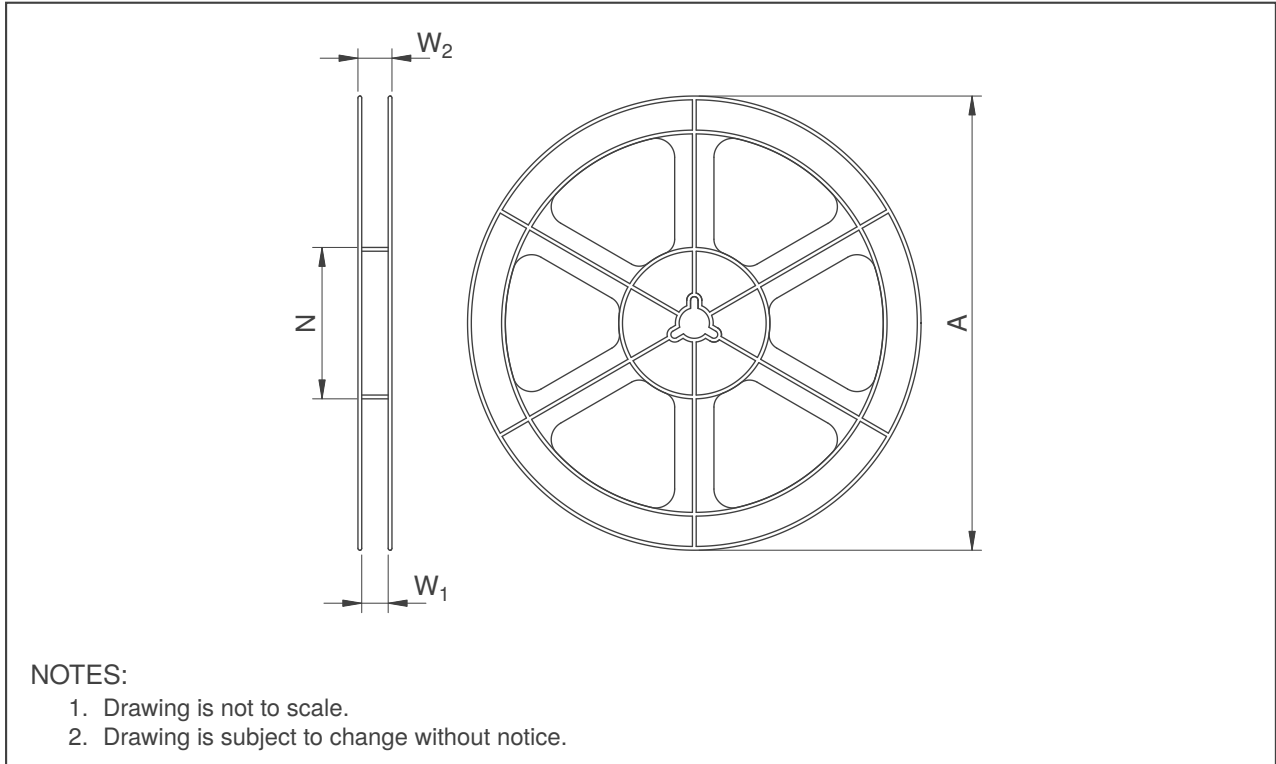

Figure 13.6: Reel Specification

Table 13.5: Reel Dimensions [mm]

Dimension	Package	
	QFN20	WLCSP11
A	178	180
N	60	60
W ₁	12.4	9
W ₂ (Max)	18.4	11.4



A Memory Map Descriptions

A.1 System Commands (0x1000)

Bit	7	6	5	4	3	2	1	0
Description	Reserved		Reseed CH0	Zero	Force ATI Hall	Force ATI CH0	Soft Reset	Ack Reset

- > Bit 5: **Reseed CH0**
 - 0: No action
 - 1: Reseed the Proxfusion channel LTA
 - Bit automatically cleared
- > Bit 4: **Zero**
 - 0: No action
 - 1: Set the processed Hall angle to the centre of interval 0
 - Bit automatically cleared
- > Bit 3: **Force ATI Hall**
 - 0: No action
 - 1: Perform ATI calibration of the Hall channels
 - Bit automatically cleared
- > Bit 2: **Force ATI CH0**
 - 0: No action
 - 1: Perform ATI calibration of the ProxFusion channel
 - Bit automatically cleared
- > Bit 1: **Soft Reset**
 - 0: No action
 - 1: Soft reset the device
 - Bit automatically cleared
- > Bit 0: **Ack Reset**
 - 0: No action
 - 1: Acknowledge a device reset
 - Bit automatically cleared

A.2 System Settings (0x1001)

Bit	7	6	5	4	3	2	1	0
Description	Reserved				f_{osc} Selection	Watchdog Period		

- > Bit 3: **f_{osc} Selection**
 - 0: 14 MHz
 - 1: 18 MHz
- > Bit 0-2: **Watchdog Period**
 - 0: 5 ms
 - 1: 9 ms
 - 2: 17 ms
 - 3: 33 ms
 - 4: 65 ms
 - 5: 257 ms
 - 6: 511 ms
 - 7: 1023 ms



A.3 I²C Settings (0x1002)

Bit	7	6	5	4	3	2	1	0
Description	Reserved				Disable Read-Only Protection	I ² C Stop Ends Comms	Event Mode	I ² C Enable

> Bit 3: **Disable Read-Only Protection**

- 0: Disabled
- 1: Enabled

> Bit 2: **I²C Stop Ends Comms**

- 0: Keep I²C communications window open on I²C stop condition
- 1: Close I²C communications window on I²C stop condition

> Bit 1: **Event Mode**

- 0: Streaming mode enabled. An I²C communications window is opened every cycle.
- 1: Event mode enabled. An I²C communications window is opened only if an enabled event occurs.

> Bit 0: **I²C Enable**

- 0: Disabled
- 1: Enabled

A.4 Event Mask (0x1003)

Bit	7	6	5	4	3	2	1	0
Description	Reserved			Hall Interval	CH0 Movement	CH0 Button	ATI	Power Mode

> Bit 4: **Hall Interval**

- 0: Disabled
- 1: Open an I²C communications window on Hall interval changes

> Bit 3: **CH0 Movement**

- 0: Disabled
- 1: Open an I²C communications window on Movement events

> Bit 2: **CH0 Button**

- 0: Disabled
- 1: Open an I²C communications window on Button events

> Bit 1: **ATI**

- 0: Disabled
- 1: Open an I²C communications window on ATI events

> Bit 0: **Power Mode**

- 0: Disabled
- 1: Open an I²C communications window on power mode changes

A.5 Power Settings (0x100A)

Bit	7	6	5	4	3	2	1	0
Description	Reserved				Halt	Auto Power Mode	Power Mode	

> Bit 3: **Halt**

- 0: Disabled
- 1: Enabled

> Bit 2: **Auto Power Mode**



- 0: Disabled
 - 1: Enabled
- > Bit 0-1: **Power Mode**
- 0: High Accuracy
 - 1: Normal
 - 2: Low
 - 3: Ultra Low

A.6 Autoprox Settings (0x100B)

Bit	7	6	5	4	3	2	1	0
Description	Reserved				Autoprox Channel	Autoprox Enable	Autoprox Conversion Count	

- > Bit 3: **Autoprox Channel**
- 0: Use ProxFusion channel as wake-up channel in AutoProx mode
 - 1: Use Hall channels as wake-up channel in AutoProx mode
- > Bit 2: **Autoprox Enable**
- 0: Disabled
 - 1: Enabled
- > Bit 0-1: **Autoprox Conversion Count**
- 0: Update all channels and UIs after 4 AutoProx conversions
 - 1: Update all channels and UIs after 8 AutoProx conversions
 - 2: Update all channels and UIs after 16 AutoProx conversions
 - 3: Update all channels and UIs after 32 AutoProx conversions

A.7 Hall Plate Selection (0x1018)

Bit	7	6	5	4	3	2	1	0
Description	Reserved		Runtime ATI	Hall Plate Selection				

- > Bit 5: **Runtime ATI**
- 0: Disabled
 - 1: Enabled
- > Bit 0-4: **Hall Plate Selection**
- 0: On-Axis Full Sampling
 - 2: On-Axis Half Staggering
 - 4: On-Axis Quarter Staggering
 - 1: Off-Axis N-S Axis
 - 17: Off-Axis W-E Axis
 - 11: Off-Axis NW To SE Diagonal Axis
 - 13: Off-Axis NE To SW Diagonal Axis
 - 6: Hall Disabled

A.8 Hall Plate Bias (0x1019)

Bit	7	6	5	4	3	2	1	0
Description	Reserved		Hall Plate Bias					

- > Bit 0-5: **Hall Plate Bias**
- 6-bit value
 - 30: 500 μ A (Recommended For 14 MHz f_{OSC})
 - 37: 600 μ A (Recommended For 18 MHz f_{OSC})



A.9 Hall Amplifier Gain (0x101A)

Bit	7	6	5	4	3	2	1	0
Description	Reserved						Hall Amp Gain	

- > Bit 0-1: **Hall Amplifier Gain**
 - 2-bit value
 - 0: x1
 - 1: x2
 - 2: x4
 - 3: x8

A.10 Hall Initialisation Delay (0x101B)

Bit	7	6	5	4	3	2	1	0
Description	Reserved					Hall Init Delay		

- > Bit 0-2: **Hall Initialisation Delay**
 - 0: 8 counts
 - 1: 16 counts
 - 2: 32 counts
 - 3: 64 counts
 - 4: 256 counts
 - 5: 512 counts
 - 6: 1024 counts
 - 7: 2048 counts

A.11 Hall Conversion Timings (0x101C)

Bit	7	6	5	4	3	2	1	0
Description	Reserved		Tx At f_{OSC}	Reserved		Hall Conversion Delay		

- > Bit 5: **Tx At f_{OSC}**
 - 0: Disabled
 - 1: Run sensor with Tx at f_{OSC} frequency. Recommended only for inductive sensing.
- > Bit 0-2: **Hall Conversion Delay**
 - 0: 8 counts
 - 1: 16 counts
 - 2: 32 counts
 - 3: 64 counts
 - 4: 256 counts
 - 5: 512 counts
 - 6: 1024 counts
 - 7: 2048 counts

A.12 Hall Dividers (0x1022)

Bit	15	14	13	12	11	10	9	8
Description	Coarse Gain							

Bit	7	6	5	4	3	2	1	0
Description	Coarse Gain							

- > Bit 0-15: **Hall Gain**



- Hall Gain can be chosen based on the following values:

Table A.1: Hall Divider Recommended Values

Gain Ratio	Register Value
3.00	0x4721
2.25	0x4921
1.33	0x4702
0.82	0x5721
0.47	0x6721
0.29	0x4E82
0.25	0x4DE6
0.17	0x4644
0.10	0x4A44

A.13 Rotation UI Settings (0x1030)

Bit	7	6	5	4	3	2	1	0
Description	Reserved		Force High Accuracy Freewheel	Freewheel UI	Reverse	Auto Zero		

- > Bit 5: **Force High Accuracy Freewheel**
 - 0: Disabled
 - 1: Device runs at High-Accuracy report rate during freewheeling
- > Bit 4: **Freewheel UI**
 - 0: Disabled
 - 1: Freewheel UI enabled
- > Bit 3: **Reverse**
 - 0: Disabled
 - 1: Reverse direction of sampled rotation
- > Bit 0-2: **Auto Zero**
 - 0: Off
 - 1: Stationary
 - 2: Continuous
 - 3: Release
 - 4: Continuous Release

A.14 Quadrature Settings (0x1044)

Bit	7	6	5	4	3	2	1	0
Description	Reserved					Discard Intervals	Quadrature Mode	

- > Bit 2: **Discard Intervals**
 - 0: Disabled
 - 1: Enabled
- > Bit 0-1: **Quadrature Mode**
 - 0: Disabled
 - 1: Open-Drain
 - 2: Push-Pull



A.15 CH0 Sensor Settings 0 (0x1046)

Bit	7	6	5	4	3	2	1	0
Description	Cs 80 pf Enable	ATI Mode		Sensing Mode		Conversion Frequency		

- > Bit 7: **Cs 80 pf Enable**
 - 0: Disabled
 - 1: Enabled
- > Bit 5-6: **ATI Mode**
 - 0: Disabled
 - 1: Divider Only
 - 2: Compensation Only
 - 3: Divider And Compensation
- > Bit 3-4: **Sensing Mode**
 - 0: Disabled
 - 1: Capacitance
 - 3: Inductance
- > Bit 0-2: **Conversion Frequency**
 - 0: 7 / 9 MHz
 - 1: 3.5 / 4.5 MHz
 - 2: 1.75 / 2.25 MHz
 - 3: 0.875 / 1.12 MHz
 - 4: 0.438 / 0.562 MHz
 - 5: 0.219 / 0.281 MHz
 - 6: 0.109 / 0.140 MHz
 - 7: 0.05 / 0.07 MHz

Note: The maximum recommended conversion frequency for capacitive sensing is 1 MHz.

A.16 CH0 Sensor Settings 1 (0x1047)

Bit	7	6	5	4	3	2	1	0
Description	Reserved		Tx At f_{osc}	Reserved		Conversion Delay		

- > Bit 5: **Tx At f_{osc}**
 - 0: Disabled
 - 1: Enabled
- > Bit 0-2: **Conversion Delay**
 - 0: 8
 - 1: 16
 - 2: 32
 - 3: 64
 - 4: 256
 - 5: 512
 - 6: 1024
 - 7: 2048

A.17 CH0 Dividers (0x104E)

Bit	15	14	13	12	11	10	9	8	
Description	Reserved		Fine Divider					Coarse Gain	

Bit	7	6	5	4	3	2	1	0
Description	Coarse Gain							



- > Bit 9-13: **Fine Divider**
 - 5-bit value
- > Bit 0-8: **Coarse Gain**
 - 9-bit value
 - Coarse Gain can be chosen based on the following values:

Table A.2: Coarse Gain Recommended Values

Gain Ratio	Register Value
4.00	258
2.00	130
1.00	66
0.50	68
0.43	206
0.29	71
0.14	78
0.07	91

A.18 CH0 UI Settings (0x1052)

Bit	7	6	5	4	3	2	1	0
Description	Reserved						Dual Threshold	Inverse

- > Bit 2: **Increase Max Counts**
 - 0: 4096 Counts
 - 1: 16384 Counts
- > Bit 1: **Dual Threshold**
 - Allow button events to trigger for both positive and negative delta values
 - 0: Disabled
 - 1: Enabled
- > Bit 0: **Inverse**
 - Set button events to trigger for negative deltas. May be necessary for inductive sensing.
 - 0: Disabled
 - 1: Enabled

A.19 CH0 Button Debounce (0x1056)

Bit	7	6	5	4	3	2	1	0
Description	Exit				Enter			

- > Bit 4-7: **Exit**
 - 4-bit value
 - Number of high-frequency samples while exiting Button state
- > Bit 0-3: **Enter**
 - 4-bit value
 - Number of high-frequency samples while entering Button state

A.20 CH0 Movement Debounce (0x105A)

Bit	7	6	5	4	3	2	1	0
Description	Exit				Enter			



- > Bit 4-7: **Exit**
 - 4-bit value
 - Number of high-frequency samples while exiting Movement state
- > Bit 0-3: **Enter**
 - 4-bit value
 - Number of high-frequency samples while entering Movement state

A.21 Button Output Settings 0 (0x106C)

Bit	7	6	5	4	3	2	1	0
Description	Reserved						IO Select	Output Enabled

- > Bit 1: **IO Select**
 - 0: MCLR / BOUT
 - 1: SDA / BOUT
- > Bit 0: **Output Enabled**
 - 0: Disabled
 - 1: Enabled

A.22 Hall Normalisation Mode (0x1085)

Bit	7	6	5	4	3	2	1	0
Description	Reserved						Hall Normalisation Mode	

- > Bit 0-1: **Hall Normalisation Mode**
 - 0: Off
 - 1: Auto
 - 2: Manual

A.23 System Status (0x2000)

Bit	7	6	5	4	3	2	1	0
Description	Reserved			Autoprox Error	Show Reset	Reserved	Power Mode	

- > Bit 4: **Autoprox Error**
 - 0: Disabled
 - 1: An error occurred with the AutoProx limits. The device will perform regular measurements rather than AutoProx conversions in Ultra Low power mode.
- > Bit 3: **Show Reset**
 - 0: Disabled
 - 1: System reset event occurred
- > Bit 0-1: **Power Mode**
 - 0: High Accuracy
 - 1: Normal
 - 2: Low
 - 3: Ultra-Low



A.24 Event Flags (0x2001)

Bit	7	6	5	4	3	2	1	0
Description	Reserved			Interval	CH0 Movement	CH0 Button	ATI	Power

- > Bit 4: **Interval Event**
 - 0: No event
 - 1: Interval change occurred
 - Cleared on read
- > Bit 3: **CH0 Movement Event**
 - 0: No event
 - 1: Movement event occurred
 - Cleared on read
- > Bit 2: **CH0 Button Event**
 - 0: No event
 - 1: Button event occurred
 - Cleared on read
- > Bit 1: **ATI Event**
 - 0: No event
 - 1: ATI event occurred
 - Cleared on read
- > Bit 0: **Power Event**
 - 0: No event
 - 1: Power mode change occurred
 - Cleared on read

A.25 Hall Flags (0x2002)

Bit	7	6	5	4	3	2	1	0
Description	Reserved		Wheel Stationary	Free-wheeling	High Accuracy	Stationary	Direction	Interval Change

- > Bit 5: **Magnet Stationary**
 - Only used when freewheeling is active
 - 0: Magnet currently moving
 - 1: Magnet stopped moving since freewheeling started. Any new movement of the magnet will stop freewheeling.
- > Bit 4: **Freewheeling**
 - 0: Virtual freewheeling is inactive
 - 1: Virtual freewheeling currently active
- > Bit 3: **High Accuracy**
 - 0: Device not in high-accuracy mode
 - 1: IQS325 sampling at high-accuracy report rate to avoid aliasing
 - This flag will get set even if Auto Power Modes is disabled, as it is also used to trigger certain events, such as automatic interval centering.
- > Bit 2: **Stationary**
 - 0: Magnet moved recently. IQS325 samples at normal or high-accuracy report rate.
 - 1: Magnet is considered stationary when interval has not changed for some time. IQS325 may transition to lower power mode.
- > Bit 1: **Direction**
 - 0: Interval change in negative direction
 - 1: Interval change in positive direction
- > Bit 0: **Interval Change**
 - 0: No interval change occurred
 - 1: Interval change occurred



A.26 Proxfusion States (0x2003)

Bit	7	6	5	4	3	2	1	0
Description	Reserved						ATI Error	Dormant

> Bit 1: **ATI Error**

- 0: No error
- 1: ProxFusion channel failed to calibrate correctly

> Bit 0: **Dormant**

- 0: Recent activity on the ProxFusion channel occurred
- 1: ProxFusion channel is considered dormant after some period of inactivity. Allows device to transition to a lower power mode.

A.27 Button Flags (0x2004)

Bit	7	6	5	4	3	2	1	0
Description	Reserved		Button Exit	Button Enter	Button LTA Halt	Button Debounce	Button Direction	Button Active

> Bit 5: **Button Exit**

- 0: No event
- 1: "Touch release" event. *Button Active* state transitioned from '1' to '0'.

> Bit 4: **Button Enter**

- 0: No event
- 1: "Touch / Button press" event. *Button Active* state transitioned from '0' to '1'.

> Bit 3: **Button LTA Halt**

- 0: LTA is filtering normally
- 1: LTA filter is halted to improve channel sensitivity

> Bit 2: **Button Debounce**

- 0: Button UI not currently debouncing
- 1: Button UI currently debouncing by sampling at high-accuracy report rate

> Bit 1: **Button Direction**

- 0: Disabled
- 1: Enabled

> Bit 0: **Button Active**

- 0: Button UI delta currently below threshold
- 1: Button UI delta currently above threshold. Button is considered "pressed".

A.28 Movement Flags (0x2005)

Bit	7	6	5	4	3	2	1	0
Description	Reserved		Movement Exit	Movement Enter	Movement LTA Halt	Movement Debounce	Movement Direction	Movement Active

> Bit 5: **Movement Exit**

- 0: No event
- 1: "Release" event. *Movement Active* state transitioned from '0' to '1' with a negative delta.

> Bit 4: **Movement Enter**

- 0: No event
- 1: "Touch" event. *Movement Active* state transitioned from '0' to '1' with a positive delta.

> Bit 3: **Movement LTA Halt**

- 0: Disabled
- 1: Enabled



- > Bit 2: **Movement Debounce**
 - 0: Movement UI not currently debouncing
 - 1: Movement UI currently debouncing by sampling at high-accuracy report rate
- > Bit 1: **Movement Direction**
 - 0: Movement delta is less than 0
 - 1: Movement delta is greater than 0
- > Bit 0: **Movement Active**
 - 0: No movement detected
 - 1: Movement occurring on ProxFusion channel. The movement UI delta is currently above the threshold.



B Revision History

Release	Date	Comments
v0.4	September 2025	Initial preliminary document released.
v1.0	October 2025	Added information regarding optimising I ² C streaming and the customisable data blocks. Added version information registers to memory map. Fixed register address numbering for ProxFusion UI Settings.
v1.1	November 2025	Added WLCSP11 pinouts, package drawings, and order code information.
v1.2	February 2026	Updated tape and reel drawings. Added IQS325002 order code (I ² C address 0x44)



Contact Information

	South Africa (Headquarters)	China
Physical Address	1 Bergsig Avenue Paarl 7646 South Africa	Room 501A, Block A T-Share International Centre Taoyuan Road, Nanshan District Shenzhen, Guangdong, PRC
Tel	+27 21 863 0033	+86 755 8303 5294 ext 808
Email	info@azoteq.com	info@azoteq.com

	USA	Taiwan
Physical Address	7000 North Mopac Expressway Suite 200 Austin TX 78731 USA	Xintai 5th Road, Sec. 1 No. 99, 9F-12C Xizhi District 221001 New Taipei City Taiwan
Tel	+1 512 538 1995	+886 932 219 444
Email	info@azoteq.com	info@azoteq.com

*Visit www.azoteq.com
for a list of distributors and worldwide representation.*

Patents as listed on www.azoteq.com/patents-trademarks/ may relate to the device or usage of the device.

Azoteq®, Crystal Driver®, IQ Switch®, ProxSense®, ProxFusion®, LightSense™, SwipeSwitch™, Dycal™, TriggerMax™, WearMax™, and the  logo are trademarks of Azoteq.

The information in this Datasheet is believed to be accurate at the time of publication. Azoteq uses reasonable effort to maintain the information up-to-date and accurate, but does not warrant the accuracy, completeness or reliability of the information contained herein. All content and information are provided on an “as is” basis only, without any representations or warranties, express or implied, of any kind, including representations about the suitability of these products or information for any purpose. Azoteq disclaims all warranties and conditions with regard to these products and information, including but not limited to all implied warranties and conditions of merchantability, fitness for a particular purpose, title and non-infringement of any third party intellectual property rights. Azoteq assumes no liability for any damages or injury arising from any use of the information or the product or caused by, without limitation, failure of performance, error, omission, interruption, defect, delay in operation or transmission, even if Azoteq has been advised of the possibility of such damages. The applications mentioned herein are used solely for the purpose of illustration and Azoteq makes no warranty or representation that such applications will be suitable without further modification, nor recommends the use of its products for application that may present a risk to human life due to malfunction or otherwise. Azoteq products are not authorized for use as critical components in life support devices or systems. No licenses to patents are granted, implicitly, express or implied, by estoppel or otherwise, under any intellectual property rights. In the event that any of the abovementioned limitations or exclusions does not apply, it is agreed that Azoteq’s total liability for all losses, damages and causes of action (in contract, tort (including without limitation, negligence) or otherwise) will not exceed the amount already paid by the customer for the products. Azoteq reserves the right to alter its products, to make corrections, deletions, modifications, enhancements, improvements and other changes to the content and information, its products, programs and services at any time or to move or discontinue any contents, products, programs or services without prior notification. For the most up-to-date information and binding Terms and Conditions please refer to www.azoteq.com.