



AZD125 - Capacitive Sensing Design Guide

Design Guide for Capacitive Buttons, Sliders and Wheels

Contents

1	Introduction	3
2	Starting a New Design	3
3	Best Practices	4
3.1	Mechanics	5
3.1.1	Basic Stackup	5
3.1.2	Overlay	6
3.1.3	Electrode and Trace Materials	7
3.1.4	Substrate	7
3.1.5	Other Situations	8
3.2	Common Layout Considerations	9
3.2.1	Routing	10
3.2.2	Spacing between Electrodes	12
3.2.3	Shapes	12
3.2.4	Crosstalk	12
4	Proximity Sensing	14
4.1	Proximity Design Considerations	14
5	Touch Buttons	15
5.1	Self-Capacitive Touch Buttons	15
5.1.1	Button Shapes	15
5.1.2	Button Performance as a Function of Overlay Thickness and Electrode Size	17
5.2	Mutual Capacitive Touch Buttons	19
6	Sliders and Wheels	21
6.1	Self-Capacitive Sliders and Wheels	21
6.1.1	Electrode Pitch	22
6.1.2	Gap between Electrodes	24
6.1.3	Layout Guidelines	25
6.2	Mutual Capacitive Sliders and Wheels	26
7	Temperature Effects	28
7.1	General	28
7.2	Follow UI Setup	28
7.2.1	Electrode Configuration	28
7.2.2	GUI Configuration	29
7.2.3	How to Determine the Follow Weight	30
7.2.4	Example Illustration of Follow Weight Calculation	31
7.2.5	Follow Weight Troubleshooting	33
8	Water Immunity and Humidity	33
9	Noise	34





1 Introduction

The art of capacitive sensing often results in multiple design iterations before specifications are met. This can be a cumbersome task for the designer. Therefore, the number of design iterations can be kept to a minimum by following good design practices. A successful touch product is achieved with a good sensor design.

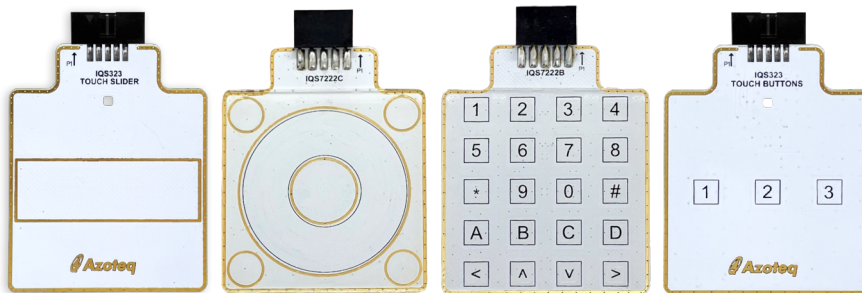

Capacitive touch applications are aimed at replacing most mechanical pads without significant added costs. Most mechanical buttons, sliders and wheels deteriorate over time, so a capacitive touch approach offers a more reliable design. Furthermore, an aesthetic value is added to the design, leaving it with a sleek, professional finish.

This design guideline aids designers with integrating ProxSense® technology into new and existing designs. The guideline will give general recommendations for a quick-start design of capacitive buttons, sliders and wheels. Please take note that this document should only guide you towards a final design. Designs discussed in this document should not be scaled directly to suit your application, and all considerations should be kept in mind. The design guidelines are for designs that employ both self-capacitive and/or mutual capacitive sensing. For a more in-depth explanation of capacitive sensing refer to [AZD004](#).

2 Starting a New Design

Some challenges may arise when starting a new capacitive touch design. This design guide provides some basic design practices for different sensors that could be used in your application. We go through the following to provide the necessary information to help you identify what sensor is best suited for your application:

- > Best Practices
- > Proximity Sensing
- > Touch Buttons
- > Sliders and Wheels

Additionally, it is important to consider the following factors in your design.

- > Temperature Effects
- > Water Immunity and Humidity
- > Noise



3 Best Practices

This section will cover the general mechanical layout for capacitive touch applications, as well as general layout practices.

Capacitive touch detection can be thought of as some form of analog-to-digital converter (ADC), more specifically a capacitance-to-digital converter. Therefore, resolution, signal-to-noise, and linearity, especially in the case of sliders and wheels, are of great importance when designing for optimum performance.

Fundamentally, capacitive touch detection is the measurement of change in capacitance. The change in capacitance is then converted to a digital signal where the strength of the signal determines the sensitivity. A stronger signal equates to a more sensitive device.

At Azoteq®, we describe sensitivity as a measure of capacitance per count. When a touch is introduced, a change in capacitance is measured. This change in capacitance can range from hundreds of femtofarads to low picofarads. If 100 counts are measured with a 1 pF change in capacitance, the sensitivity can be described as 10 fF/count. It should be noted that the sensitivity of the device must factor in noise. Although sensitivity can be adjusted within firmware, it is better to design the hardware for good sensitivity, thus providing optimal, low-noise device performance even at the lowest sensitivity settings in firmware.

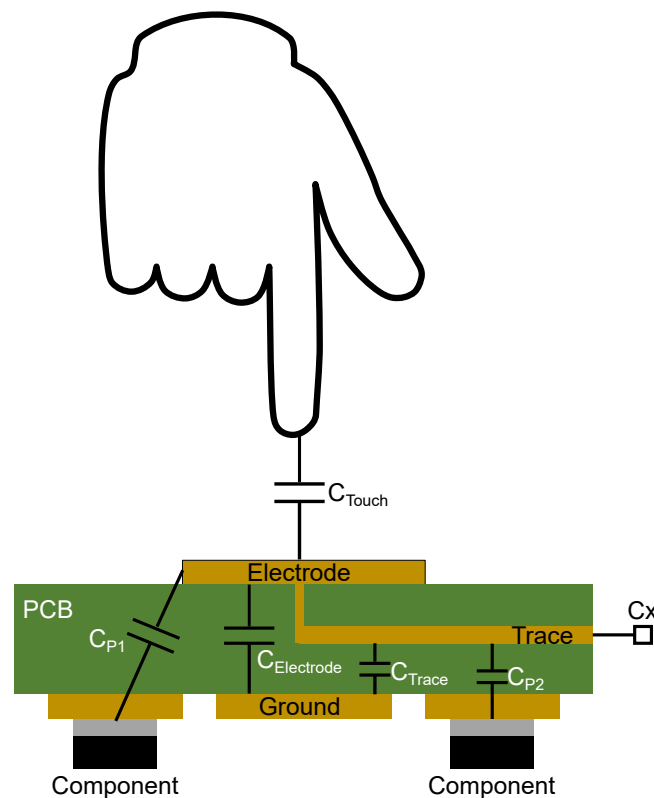

Figure 3.1: Equivalent Circuit Parasitic Capacitance

If we look at the equivalent circuit of a self-capacitive sensor, we see that the capacitance measured by the Cx pin is made up of multiple capacitances. The goal is to maximize C_{Touch} and minimize parasitic capacitances $C_{Electrode}$, C_{Trace} , C_{P1} and C_{P2} . The trace and electrode capacitances are approximated as parallel plate capacitances. The capacitance of a parallel plate configuration can be calculated with the following equation:

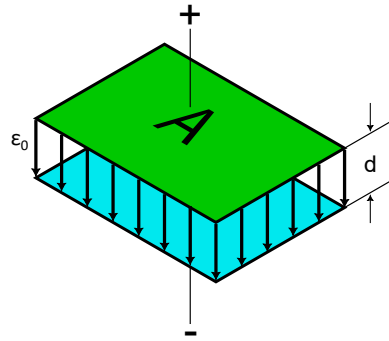

Figure 3.2: Capacitance illustration

$$C = \frac{\epsilon_r \epsilon_0 A}{d} \quad (1)$$

Where ϵ_r is the dielectric constant, ϵ_0 is the vacuum permittivity constant, A is the surface area of the plate and d is the distance between the parallel plates. The capacitance equation forms the basis for the design of capacitive touch sensors.

As mentioned previously, the parasitic capacitance is a part of the measured signal and can be described as the steady-state or baseline capacitance. Therefore, decreasing the parasitic capacitance will increase sensitivity.

3.1 Mechanics

The mechanics of the design include the overlay, the overlay decal, the adhesive that bonds the overlay to the electrode, and the material used to fill air gaps between the electrode and overlay. Parasitic capacitance is affected by the mechanics, which in turn affects the signal measured by the capacitive sensor.

This section describes how different materials used in the stack-up affect the layout of the electrode.

3.1.1 Basic Stackup

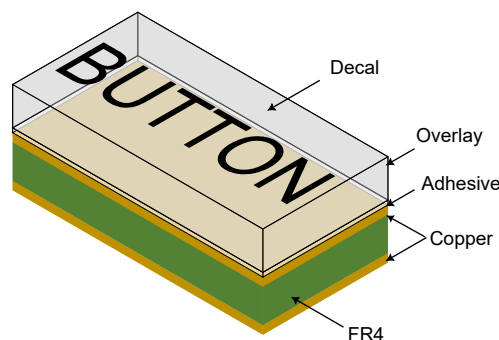

Figure 3.3: Capacitive touch mechanical stackup

A typical capacitive touch mechanical stackup is shown in figure 3.3. As mentioned previously, the capacitive sensor measures the change in capacitance, therefore, a bigger change in capacitance provides a stronger signal. With this in mind, we aim to optimise the performance of the capacitive touch sensor by reducing low-dielectric gaps, such as air, between the electrode and touch area.



Air gaps also provide an area for moisture to build up, which could influence the performance of the device. High-dielectric materials are recommended for improved performance.

It should be noted that the stackup should not contain conductive material.

3.1.2 Overlay

An overlay is a non-conductive material used to isolate the touchpad from the user. They are generally used to increase the robustness of a capacitive touch design, enabling the design to withstand higher levels of ESD. They also add to the aesthetic value of the design, as custom prints can be done on the side that is in contact with the sensing pad, which can be seen through the overlay in figure 3.4. This also allows for the sensing pad to be bigger than the printed graphic without affecting the user's interpretation of the pad.

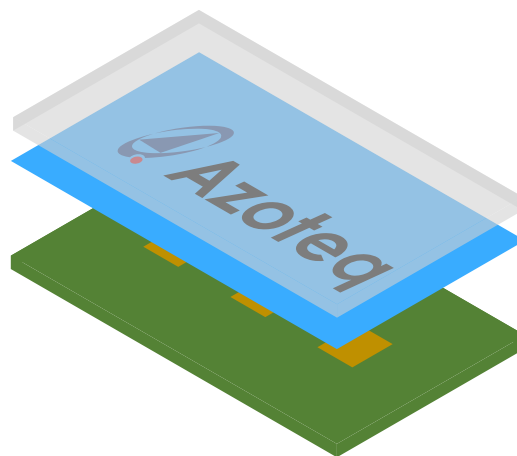

Figure 3.4: Custom print behind the overlay

Conductive materials should not be used for the overlay. Different materials have different relative permittivity (dielectric constant - ϵ_r) values, which are directly linked to the propagation ability of an electric field through the material. The higher the relative permittivity, the better the electric field will propagate through the material. This relates to equation 1, where an increase in ϵ_r will increase the capacitance, which in turn increases sensitivity.

Typical overlay materials include Perspex/Plexiglass ($\epsilon_r = 2$ to 3), and glass ($\epsilon_r = 7$ to 8), but other plastic materials or even PCBs (FR-4) can be used. Some common overlay materials as well as their relative permittivity and breakdown voltage (relevant for ESD testing) are provided in table 3.1.

Material	Relative Permittivity (ϵ_r)	Breakdown Voltage (V/mm)(approx.)
Air	1.0	3000
Glass (standard)	7.6-8.0	7900
Plexiglass	2.8	17700
Mylar	3.0	295200
FR-4	5.2	27500
Nylon	3.2	16000

Table 3.1: Overlay material relative permittivity and breakdown voltage



The overlay thickness can range from 0.8 to 10 mm (0.8 mm to 3 mm is recommended for most typical applications), where the thickness is dependent on the application. In the case of self-capacitive sensing, a thinner overlay provides better sensitivity. Where mutual capacitance is used, a thicker overlay could help with sensitivity to a certain extent.

Good contact between the overlay and the sensing pad is very important. The overlay should be directly mounted to the substrate containing the sensing pad and preferably touching the sensing pad. There should not be any play between the overlay and the sensing pad as this can cause unwanted mechanical effects. Preferably, adhesives such as non-conducting glue /double-sided adhesive tape or other mechanical compression mechanisms (plastic screws /spring clips/etc) can be used to fix the overlay to the substrate containing the touch pads.

Example adhesive materials include 3M’s 467 and 468 model tapes, which are widely used for capacitive sensing applications.

3.1.3 Electrode and Trace Materials

The conductive material of the electrode and trace affects the ability of the conductor to move charge. An increase in resistivity has a similar effect to an increase in parasitic capacitance, which reduces sensitivity. We recommend using copper for most applications. The charge transfer capacitive sensing method, mentioned in [AZD004](#), can handle resistive paths. Please refer to [AZD102](#) for more information on capacitive sensing differences when using resistive paths higher than the recommended schematic.

3.1.4 Substrate

The material on which the key electrodes are placed is called the substrate. The electrodes should be electrically conductive and in contact with the substrate material.

Capacitive sensor conductor and PCB/FPC substrate types include copper tape, printed ink on plastic, traditional FR-4, FPC variations, and simple insulated wire. Below are commonly used examples with preferred suitability for capacitive sensor use.

Material	ϵ_r @1MHz	Parasitic Load Susceptibility	Temperature Dependency
FR-4 (N4000-29)	4.5	MEDIUM	MEDIUM
FPC (PET)	3.4-3.5	HIGH	HIGH
PI (Kapton)	3.4-3.8	MEDIUM	MEDIUM
Printed ink (on ABS) or LDS Technology	2.8	LOW	LOW
Co-axial (PTFE dielectric)	2.1	HIGH	HIGH
Insulated Wire	≈1	LOW	LOW

Table 3.2: Substrate material parasitic load susceptibility and temperature dependency

The relationship between the different materials can be seen in figure 3.5.

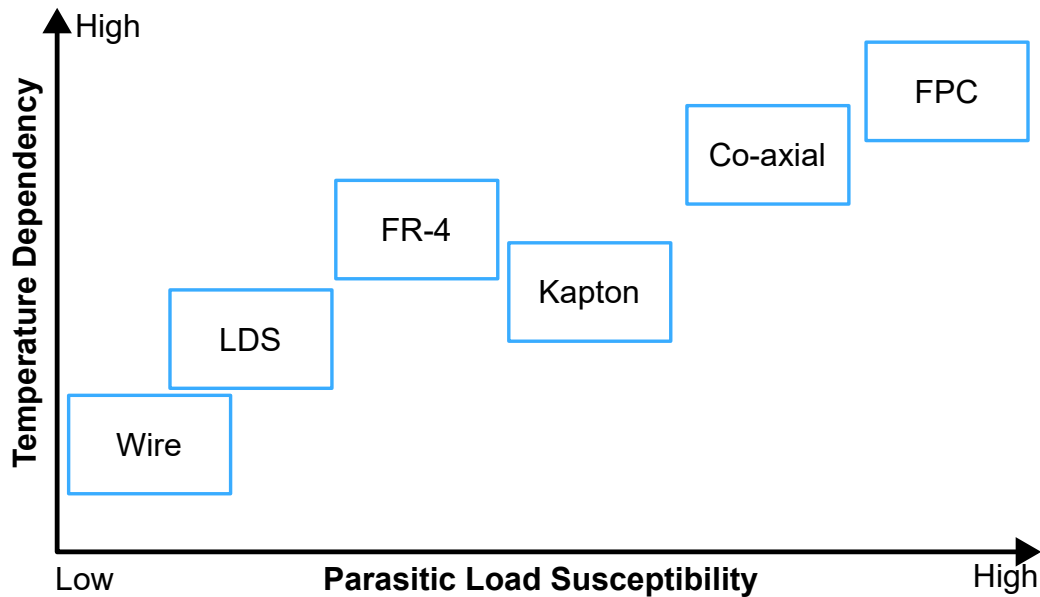

Figure 3.5: Substrate comparison

3.1.5 Other Situations

This section describes two situations that do not typically occur. The first case that needs to be considered, is air gaps between the electrode and overlay, and the second case is the use of gloves when operating capacitive touch pads.

Gaps

There are cases where components are on the same layer as the electrode. This creates a gap between the electrode and overlay as the components prevent the overlay from making direct contact. An example of this can be seen in figure 3.6.

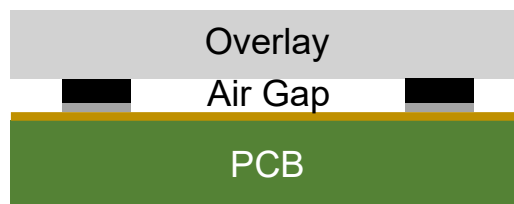

Figure 3.6: Air gap between overlay and electrode

An air gap could form when the overlay material is not a uniform surface, therefore, the electrode may not make direct contact with the overlay. Springs and conductive rubber or carbon contacts work well to remove the air gaps between the PCB and the overlay. In applications where it is not possible to fix the electrode PCB to the overlay, conductive rubber or carbon contacts work well to remove small air gaps, whereas larger air gaps can be removed with springs.



As previously discussed, air has a low dielectric constant. From equation 1, we see that the capacitance with a 1 mm air gap dielectric (without moisture) is approximately the same as the capacitance of an 8 mm thick glass dielectric. This can be seen in figure 3.7.

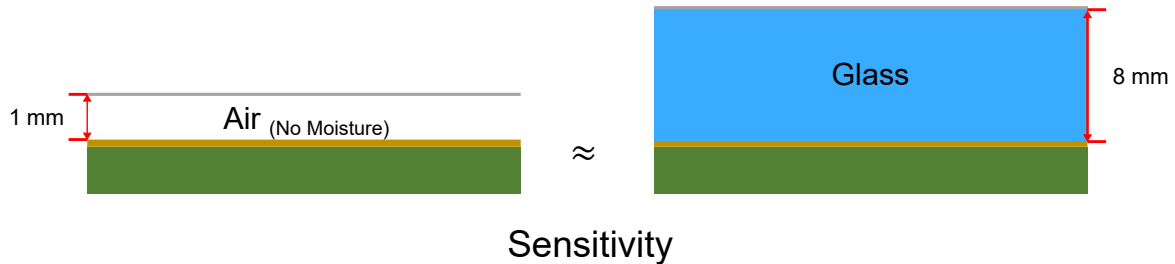

Figure 3.7: Overlay comparison

As previously mentioned, it is recommended that the air gap be filled with a carbon contact or a conductive rubber. The conductive rubber should be malleable to conform to the shape of different components and surfaces. The dielectric value of the filler material should be taken into consideration when deciding on the material to fill the air gap.

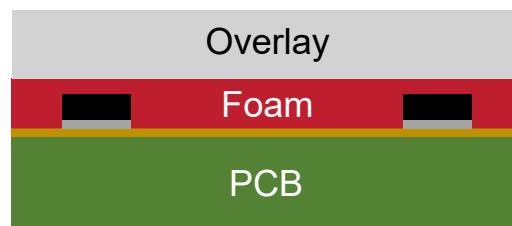

Figure 3.8: Foam filled in between overlay and electrode

Gloves

There are applications where capacitive touch is used in conjunction with gloves. Gloves add another dielectric medium between the sense electrode and the finger. Applications that require gloves can become challenging when designing for both gloved and gloveless operation. Alternative user interface options are typically implemented when the application involves the use of gloves. In most cases, a "tap-gesture" interface allows for successful operation with and without gloves. For optimizing capacitive sensor applications that require the use of gloves, please contact Azoteq®.

3.2 Common Layout Considerations

Once the mechanics of the design are recognized and before the design of the capacitive touch application, it is important to consider how the layout design is affected by the distance between the IC and the capacitive electrode, the PCB stackup and other PCB circuitry.

First consider the placement of external components related to the capacitive touch solution such as decoupling capacitors used on power lines, and ESD protection components like current limiting resistors. These components should be kept as close as possible to the IC to reduce noise coupling and/or ESD conducting into the device.

The following sections will discuss methods of reducing parasitic capacitance and crosstalk. Refer to [AZD004](#) for an explanation of parasitic capacitance.

3.2.1 Routing

Optimised routing and pad placement will greatly increase capacitive detection sensitivity by reducing parasitic capacitances of the trace.

Length and Thickness: PCB manufacturing capabilities directly affect the ability to reduce parasitic capacitances by allowing tighter tolerances. This allows smaller trace widths and larger separation, resulting in lower capacitance per unit length. The trace length between the pad and the IC should be kept as short as possible. A trace width (W) of 0.2 mm is good, but thinner is better.

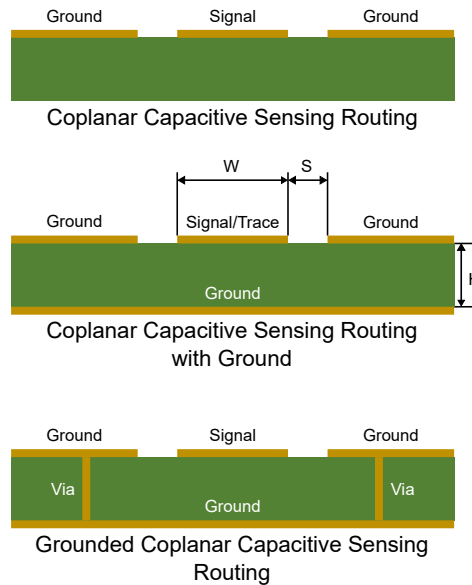

Figure 3.9: Coplanar waveguide, coplanar waveguide with ground and grounded coplanar waveguide

Any "coplanar capacitive sensing routing" with GND on the bottom layer may be beneficial for RF immunity and other shielding purposes but will be more susceptible to temperature changes and other environmental effects. In most cases where the user cannot touch the traces, coplanar capacitive sensing routing without GND on the opposing layer is an optimal solution when it comes to sensing performance.

Increasing the separation (S) between the trace and ground will effectively reduce the parasitic capacitance. It should be noted that increasing the separation increases the board size. A larger separation also makes the trace more sensitive to touch events.

As the height of the substrate (H) gets smaller, the parasitic capacitance increases. For most applications where a 2-layer PCB is used, we recommend a standard FR-4 PCB with a thickness of 1 mm to 1.6 mm. In the case of a multilayer PCB, H should be kept as large as possible to reduce the parasitic capacitance.

Components: As mentioned previously, it is important to place C_x resistors as close as possible to the IC, as this will increase RF immunity. The supply capacitors on VDD and VREG should also be placed as close as possible to the IC.



Routing to other pads or components should not occur behind touch pads. If possible, place touch pads on the top layer of the PCB (closer to the user) and route traces, leading to the pad, on the bottom layer and connect the traces with a via. The touchpad traces should be properly spaced (maximum allowable for design), as this will decrease the coupling between sensors and increase sensitivity. Routing should not occur between touchpads as this could cause false touch detections if they are accidentally touched. Try to keep the pads a minimum length of the overlay thickness away from any trace or at least 5mm.

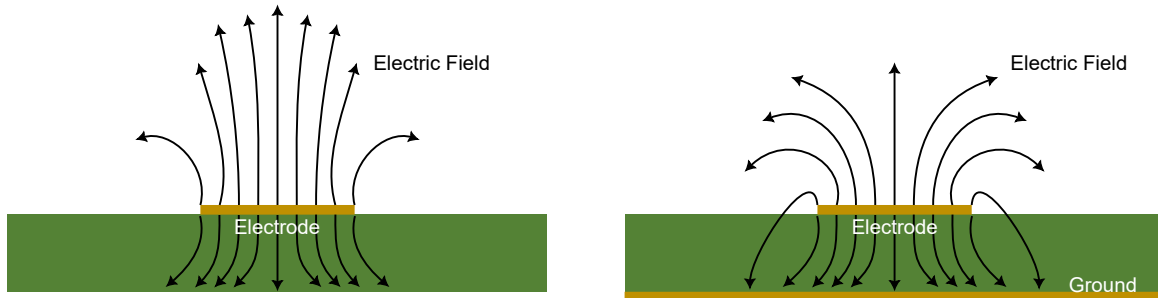

Figure 3.10: Ground effect on E-field

Ground pours close to an electrode (closer than 5 mm) are undesirable due to the parasitic capacitance that lowers the sensitivity. This effect can be seen in figure 3.10. More parasitic capacitance is present when the sensing electrode is parallel to the ground pour. Although new-generation ICs can compensate for larger parasitic capacitance in the system, the ground around the sensing area will still attract the field lines which can cause a perceived reduction in sensitivity.

Ground pours greatly improve EMC immunity when placed around and on the opposite side of a ProxSense® or ProxFusion® IC. It is recommended to place ground pours for applications requiring improved EMC immunity. It should be noted that a clearance between the “ground pour” and any sensing lines (Cx pour and traces) should be maintained. Please refer to the application notes on EMC design for further details (AZD051 & AZD052).

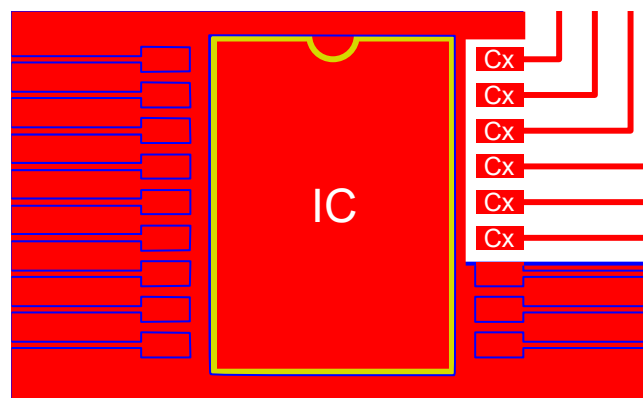

Figure 3.11: Ground pour omitted behind sense electrodes



A hatched ground is another method of reducing the parasitic ground area and consequently the parasitic capacitance. This can be seen in figure 3.12.

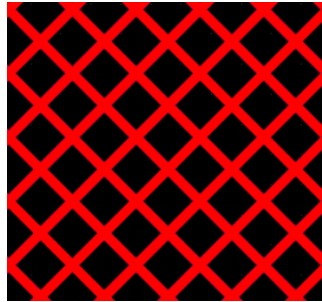

Figure 3.12: Hatched Ground

As previously mentioned, it is recommended that copper be used for routing and the electrode. Please contact Azoteq[®] if other materials are required for your design.

3.2.2 Spacing between Electrodes

Azoteq[®]'s ProxSense[®] and ProxFusion[®] devices allow non-active electrodes to be driven to ground, effectively treating adjacent electrodes as an extension of the ground pour. Therefore, the same rules for spacing between an electrode and ground apply here. It is necessary to provide enough separation between electrodes to allow the E-field to propagate up and through the overlay material.

Spacing between electrodes should be considered for button applications, as wheels and sliders require the spacing between electrodes to be small enough that performance is not affected. The spacing between electrodes should be sufficient to avoid false touch detections, like triggering two buttons when only one button-press was intended.

3.2.3 Shapes

As seen in equation 1, capacitance is a function of area, which will be affected by the shape of the electrode. The electrode should be designed to maximize the area to increase the capacitance when a touch event occurs. This is discussed further in sections 5 and 6.

3.2.4 Crosstalk

This section discusses different sources of parasitic capacitances and coupling. These sources can either be other capacitance sensor traces or non-capacitance sensor lines routed near the active sensing trace. Non-capacitive sensor lines include digital signals, analog signals, high-current signals to drive LEDs, class D amplifiers at low-frequency kilohertz range and NFC signals.

Adjacent Capacitive Touch Signals

Capacitive touch sensor traces can be affected by adjacent capacitive touch sensor traces that use a different sensing engine during the same time slot. In this case, the space between the sensor traces should be kept at a safe distance to reduce coupling. Sensors that are routed next to each other, but sensed in different time slots are typically not prone to the effects of crosstalk. Coplanar ground traces (Figure 3.9) are recommended in cases where crosstalk is possible between sensor lines.



Digital Signals, LEDs and LED Backlighting

Digital signals such as PWM signals, I²C or SPI are active during a capacitive measurement, unlike other capacitive traces. It is recommended that the signals be kept a minimum of 4 mm away from the capacitive sensor traces and if they must cross, keep the crossing at an angle of 90°. LEDs may also be driven by digital signals and therefore, it is recommended that the LED driver line be kept a minimum of 4 mm away from the capacitive sensor traces.

Ideally, LEDs should be driven by a constant current and not pulsed (for example via PWM, a form of "high-impedance control"). There is a difference in the on- and off-state capacitance when high impedance is used to prevent the LEDs from conducting. Worst case, this difference in capacitance can be interpreted as a false touch detection. It is recommended that a discrete capacitor (typically 1 nF) be used in parallel with the LED if high-impedance control is unavoidable.

If an LED is used behind the capacitive touchpad, the hole should be kept as small as possible to avoid dead spots in the sensor. These LEDs may require a bypass capacitor.

4 Proximity Sensing

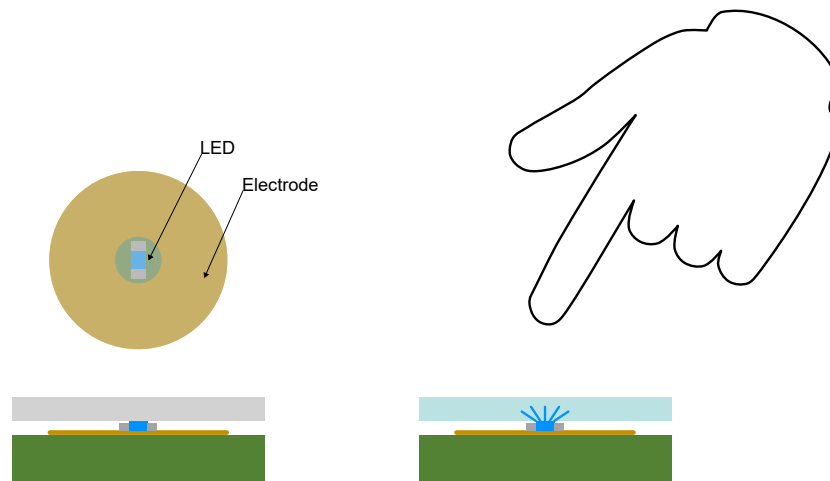

Figure 4.1: Light up button LED using proximity

Proximity sensing is the method of detecting a finger, hand or body, at some distance away from the sensing electrode. The electrode is designed for greater sensitivity to allow the ranged detection. Proximity sensors in your design can allow for reduced system power consumption and provide feedback when there is human interaction with the system.

4.1 Proximity Design Considerations

The range of the proximity sensor is dependent on various factors:

- > The size and shape of the proximity sensor
 - The sensing range increases with electrode size.
 - The range is also dependent on the size of the approaching object.
- > The sensors configured tuning values
 - The range is increased with higher tuning values.
 - These include the gain and proximity threshold.
- > The surrounding conductor
 - The proximity range increases by increasing the separation between the sensor and surrounding conductors such as ground.
 - In the case of mutual capacitance, an increase in the separation between the Rx and Tx electrode also increases the sensing range.
 - A capacitive system well connected or coupled to earth will increase the proximity performance of a user (typically well coupled to earth).
- > The surrounding environment
 - Increasing the sensing range of the proximity sensor will also increase the effects of temperature drift, humidity, and noise due to an increase in sensitivity.

Therefore, it is important to carefully balance the sensor size, configurations, and stability.

5 Touch Buttons

Buttons are simple square or circular electrodes that are used to detect a finger touch.

This section will discuss both self-capacitive and mutual capacitive button designs.

5.1 Self-Capacitive Touch Buttons

A self-capacitive button sensor requires a single electrode to measure a change in capacitance caused by a touch. Self-capacitive buttons are straightforward to layout and only use one input pin on the IC.

5.1.1 Button Shapes

The electrode is most commonly circular or rectangular with sizes 10 mm and smaller. A touch pad from as little as 5mm x 5mm can also be used but will require a thin overlay and should be properly tested.

A rounded shape provides a more uniform field. However, the shape of the button is not as important as the area of the pad (A), the dielectric constant of the overlay material (ϵ_r), and the thickness of the overlay (d). Figure 5.1 shows an example of the self-capacitive button layouts.

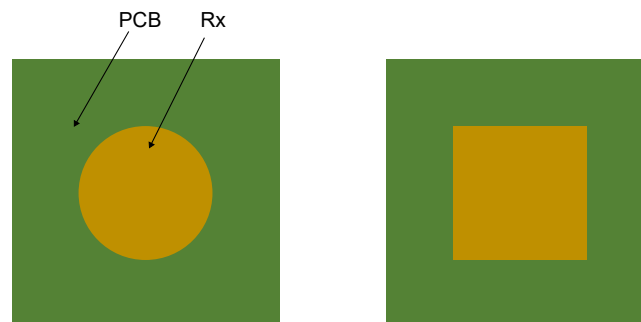

Figure 5.1: Circular and rectangular self-capacitive touch buttons

The pad size and overlay graphic does not have to be the same size. It is good design practice to have a larger pad behind the overlay, as sensitivity decreases at the edges of a pad. The button area should provide a sufficient signal when a touch is made. Usually, an ink or a non-conductive decal is used to identify the touch button. The size of the electrode can be made bigger than the decal so that a touch on the edge of the decal will register a touch. This can be seen in figure 5.2 below.

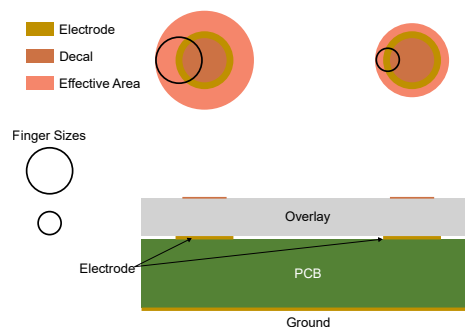

Figure 5.2: Effective sensing area for an electrode larger than the Decal



An electrode smaller than the decal will ensure that a touch activation only occurs in the centre of the decal. This can be seen in figure 5.3 below.

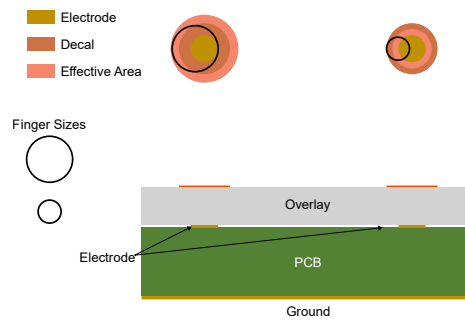

Figure 5.3: Effective sensing area for a decal larger than the electrode

A common mistake made when designing a self-capacitive button is making the electrode the same shape as the printed icon/decal. This leads to a reduced surface area and discontinuities in the capacitive electrode. This design is seen in figure 5.4 on the left.

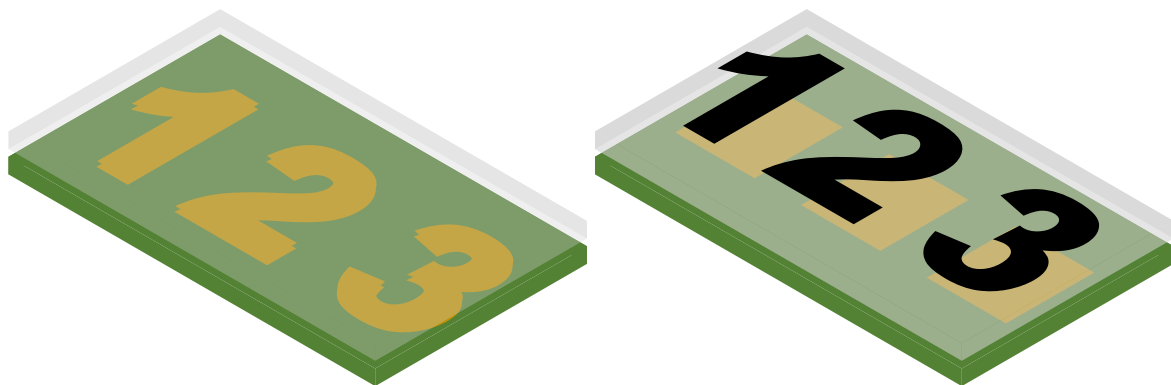

Figure 5.4: (Left) Bad electrode design. (Right) Common electrode shape under custom decal.

The electrode should instead be the more common rectangular or circular shape while the decal can be any shape that is required while still covering the electrode as seen in figure 5.4 on the right.



5.1.2 Button Performance as a Function of Overlay Thickness and Electrode Size

Before determining the performance of the button, it's important to first define its functions. For example, a button may be required to activate with a hovering finger, a touching finger or both. Once the application has been determined, the electrode size and overlay can be determined.

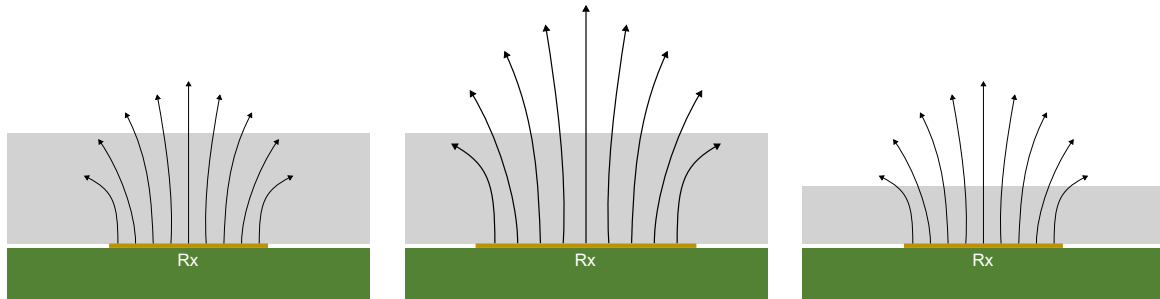

Figure 5.5: (Left) Default setup. (Middle) Larger electrode. (Right) Thinner overlay.

For self-capacitive sensing, a larger electrode will give more sensitivity. An increase in sensitivity is also seen for a thinner overlay. This can be seen in figure 5.5 above.

Figure 5.6 below illustrates the difference between the proximity function and the touch function for a self-capacitive button. With the proximity function, the electrode is required to detect the user at a given distance above the overlay, while a touch is defined as making physical contact with the overlay.

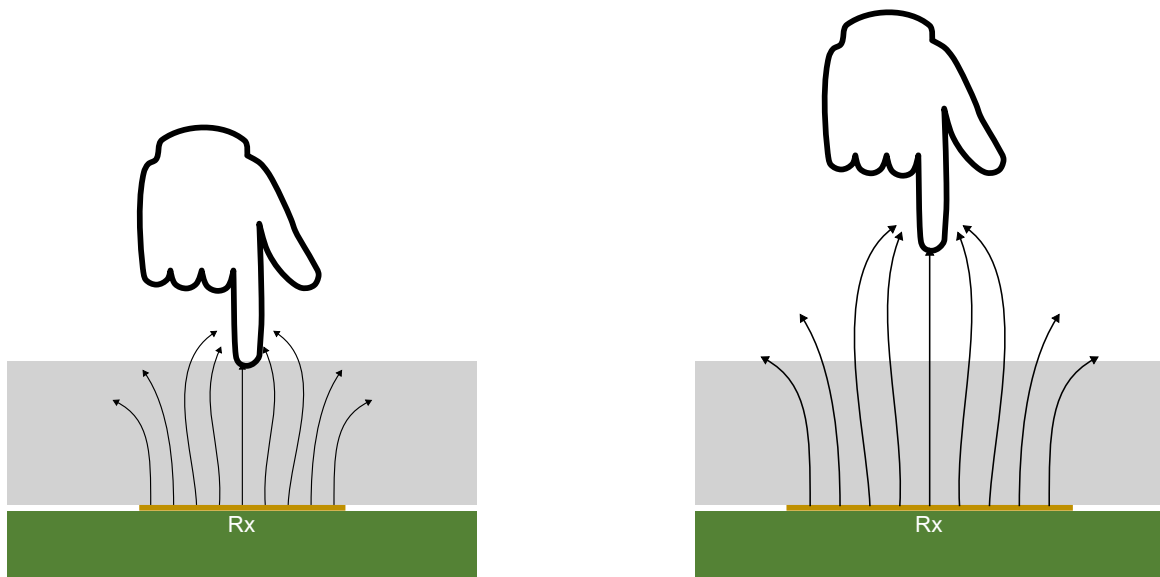

Figure 5.6: (Left) Touch button application. (Right) Proximity button application.



For touch applications, the design would need to be optimised so that a touch is detected only once contact is made with the overlay. For proximity applications, there should be an almost linear change in capacitance as a finger is brought closer to the electrode. A proximity vs touch activation profile can be seen in figure 5.7 below. In the case of proximity, as the finger approaches the electrode there is a gradual increase in delta counts (increase in capacitance). For touch applications, there is a sudden increase in delta counts (increase in capacitance) when contact is made with the overlay.

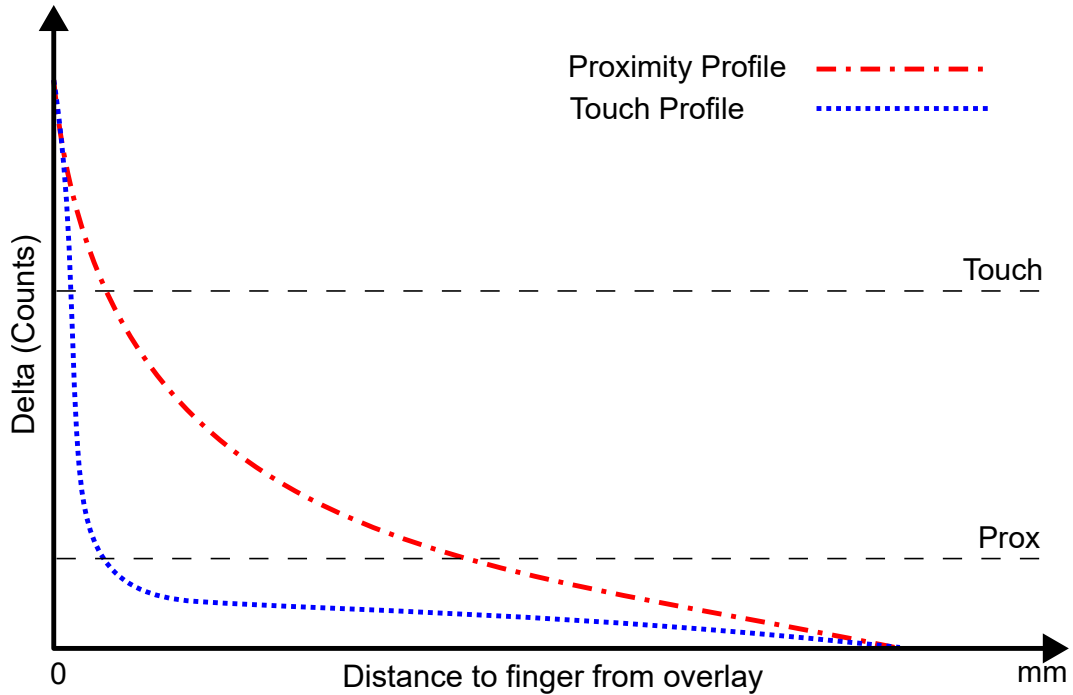

Figure 5.7: Touch vs proximity activation profile



5.2 Mutual Capacitive Touch Buttons

A mutual or “projected” capacitive button sensor requires two electrodes - one functions as a Tx, while the other functions as a Rx. It is possible to pack the electrodes closer together with a low risk of cross talk between neighbouring electrodes. With mutual capacitive electrodes, multi-touch is also possible by multiplexing the channels.

The electrode shape is typically rectangular with common sizes being 5 to 15 mm. Figure 5.8 below shows an example configuration.

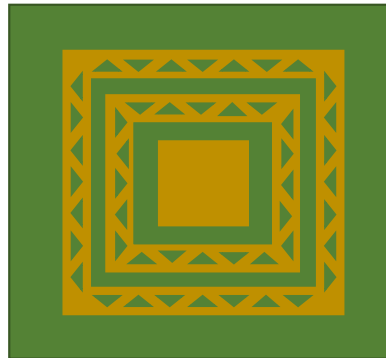

Figure 5.8: Mutual capacitive touch button

Figure 5.8 shows a top view of an example mutual capacitance button having a Tx, Rx and GND pour. The Tx and Rx are shown to be hatched for improved performance. Figure 5.9 below shows the typical dimensions of the electrodes for a small 6 mm button. Additionally, a side view of the PCB is given showing the overlay. For an overlay with 1 mm thickness, the Tx and Rx have a typical width of 0.7 to 1 mm. The gap between the Tx and Rx should be approximately half of the width of the electrode. Finally, the gap between the Rx and the GND plane in the middle should be (1) equal to or greater than 0.5 mm, and (2) should always be greater than the width of the Tx-Rx gap.

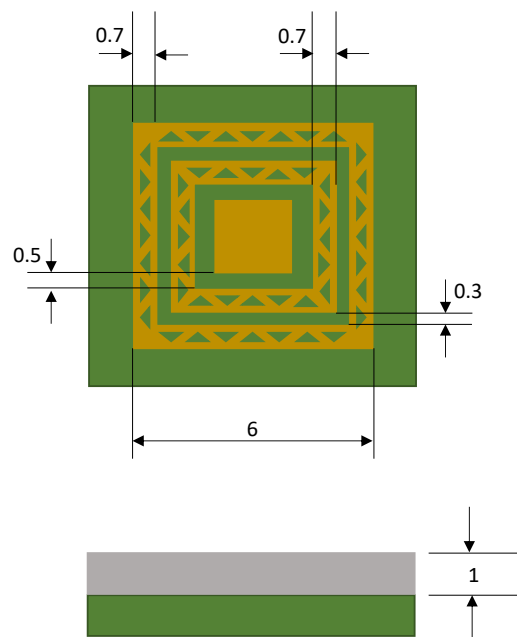

Figure 5.9: Top and side view of 6 mm button with 1 mm overlay



The electrode dimensions shown for the small button stays the same for a bigger button, if the overlay thickness stays the same. This is illustrated in figure 5.10. The GND plane in figure 5.10 is noticeably bigger than the GND plane in figure 5.9, which may lead to unresponsiveness in certain applications. If this is a concern, please contact Azoteq® for assistance.

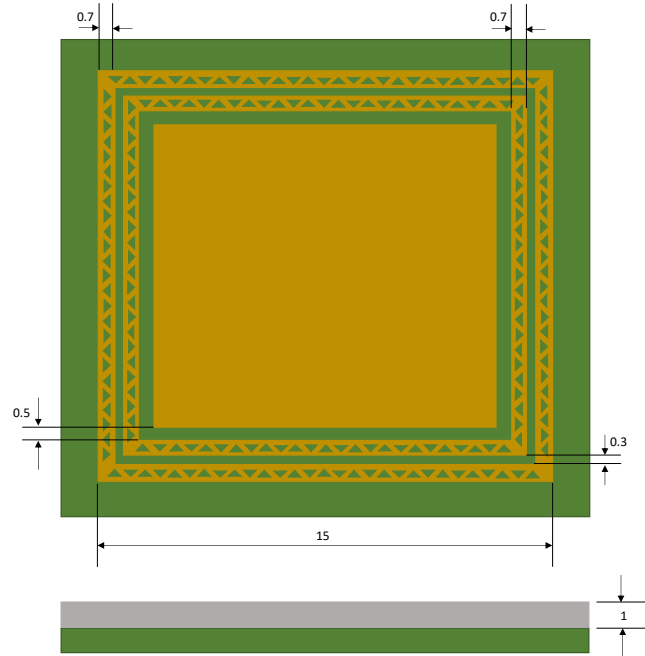

Figure 5.10: Top and side view of 15 mm button with 1 mm overlay

It should be noted that the dimensions given here will scale with overlay thickness. For example, an overlay of 2 mm thickness will have electrode widths of 1.4 to 2 mm, and the Tx-Rx gap is increased to 0.6 mm, while the Rx-GND gap is increased to 1 mm, as indicated in figure 5.11.

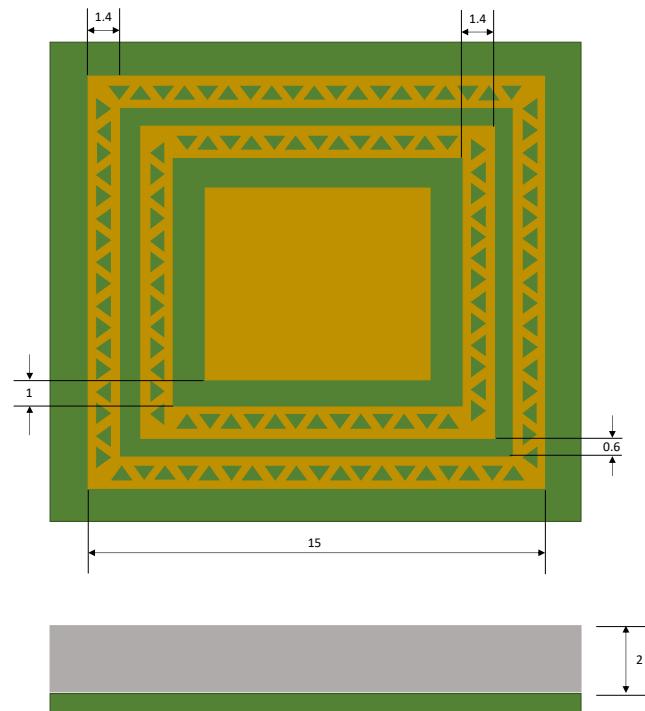

Figure 5.11: Top and side view of 15 mm button with 2 mm overlay

6 Sliders and Wheels

A Slider or wheel is a multi-element sensor used for designs that use volume control, brightness control or LED color blending. Usually, designs make use of 3 to 4 electrodes, but more elements can be used. The upper limit of elements is restricted by the number of channels available on the IC. More elements increase complexity as routing becomes more difficult, but provides easier access to increased linearity.

The designer would have to decide whether a self-capacitive slider or a mutual capacitive slider will be used for their end application.

- > Self-capacitance
 - Simple to design
 - Simple to route, especially on single-layer designs
 - One Cx pin per electrode
- > Mutual capacitance
 - Extra Cx pin needed for Tx electrode
 - The method creates local E-field between Rx and Tx electrodes reducing electromagnetic crosstalk with nearby sensors
 - Better moisture rejection than a self-capacitance sensor
 - Tx track must be shielded from Rx tracks by routing ground between them

This section provides a brief overview of important aspects that one should be aware of when designing a touch slider or wheel.

6.1 Self-Capacitive Sliders and Wheels

A self-capacitive slider can be created by placing a row of self-capacitive electrodes (elements) close to each other while a self-capacitive wheel is created with electrodes in a circular formation close to each other. Typically, 3 or 4 elements are necessary to get optimal performance. The measured signal on the self-capacitive channels are used to calculate a touch coordinate. Coordinate linearity can be improved by interdigitated sensor electrodes and an increased number of sensor elements.

For simplicity, the design of a self-capacitive slider will be explained but the same considerations apply to the self-capacitive wheel.

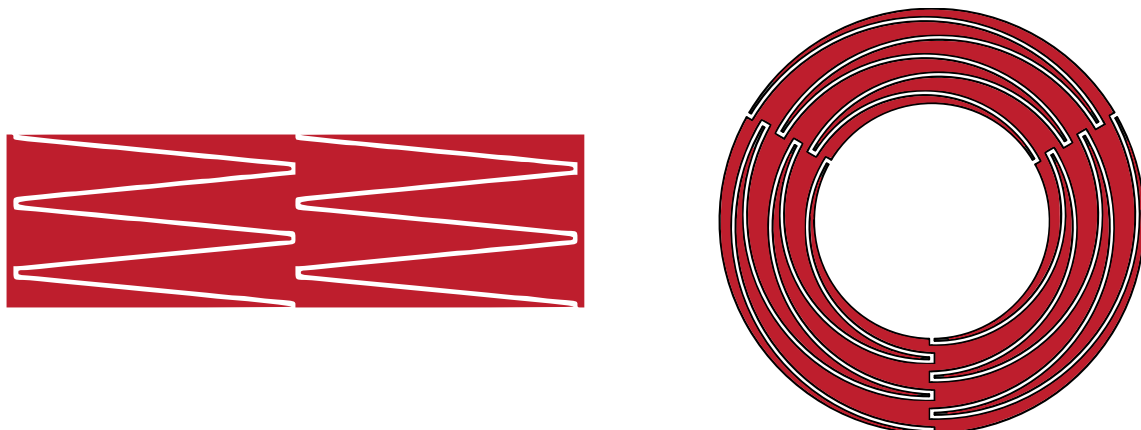

Figure 6.1: Touch slider and wheel

6.1.1 Electrode Pitch

The pitch of the elements should be at least half the width of a fingertip. As mentioned previously, a typical user's fingertip may be approximated as a circle with a diameter between 5-10 mm and on average 8 mm. A pitch bigger than approximately 8 mm with no interdigitation will lead to poor coordinates calculated versus the actual touch location on the slider. Only one of the elements will be in a touch state as the touch moves across the slider, which means there will only be a signal on one of the channels.

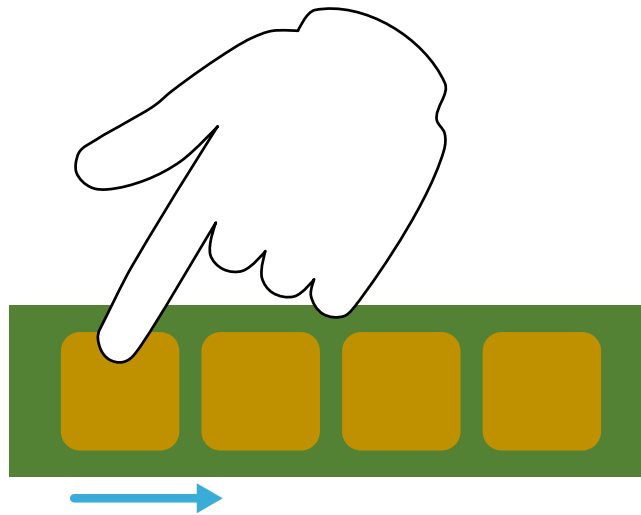

Figure 6.2: Self-capacitive slider with a larger pitch

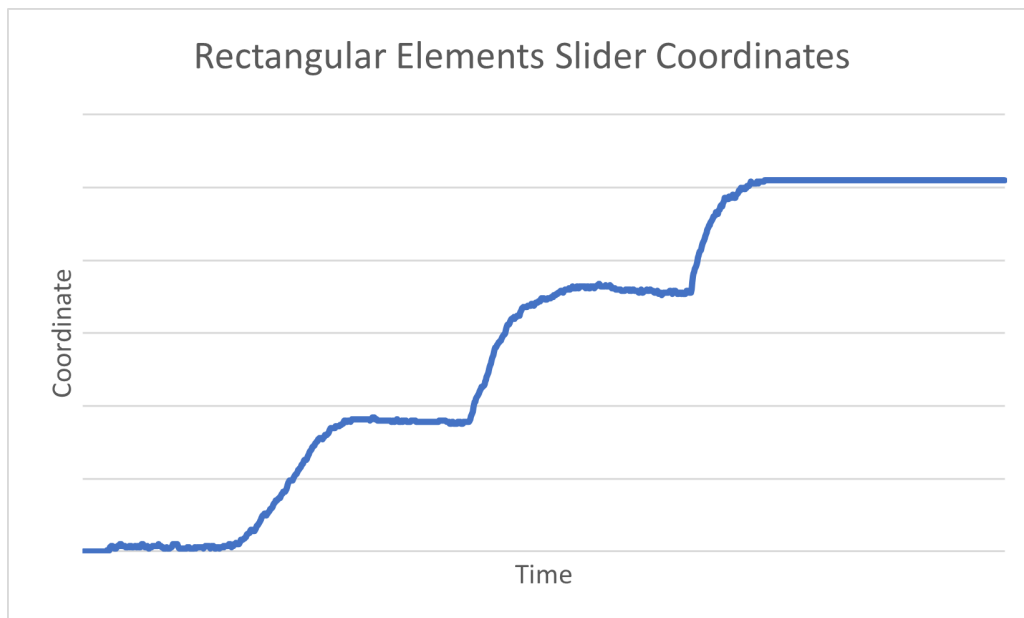

Figure 6.3: Self-capacitive slider with a larger pitch (Response)



The linearity of the slider or wheel can be improved by reducing the sensor pitch to below half the width of the touch which will be made. At least 2 or 3 of the elements will be under the touch area when the sensor pitch is approximately 4 mm. A coordinate can then be calculated using the deltas on 2 or 3 channels which will provide a more accurate coordinate.

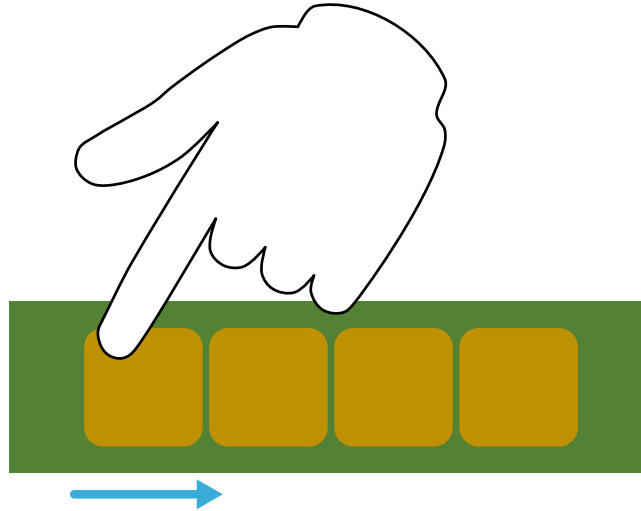
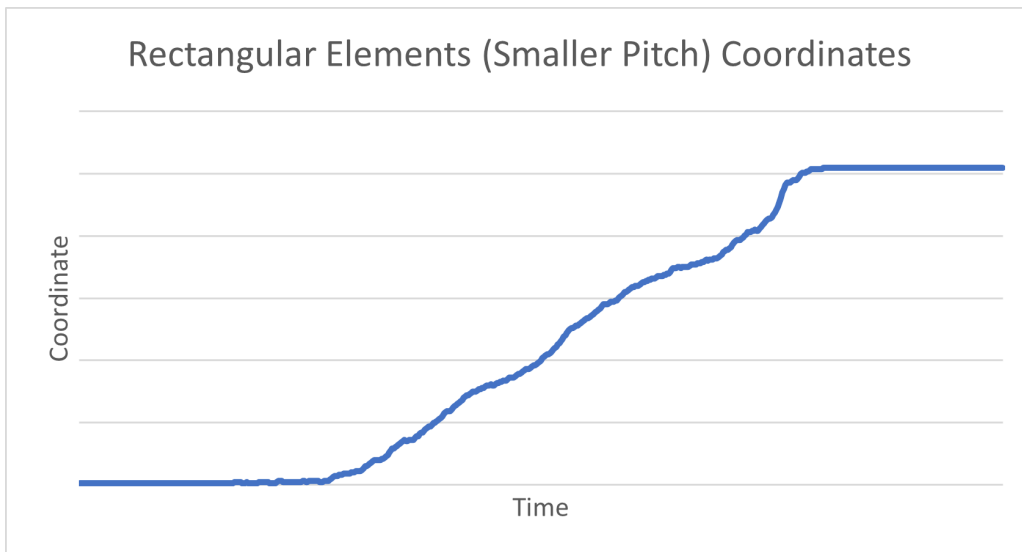

Figure 6.4: Self-capacitive slider with a smaller pitch



Interdigitated electrodes can further improve linear coordinate output by stretching the crossover between electrodes. Fewer channels are needed for a linear coordinate output.

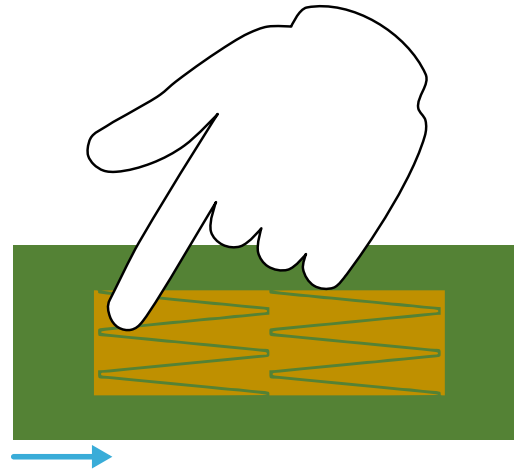

Figure 6.6: Interdigitated self-capacitive slider

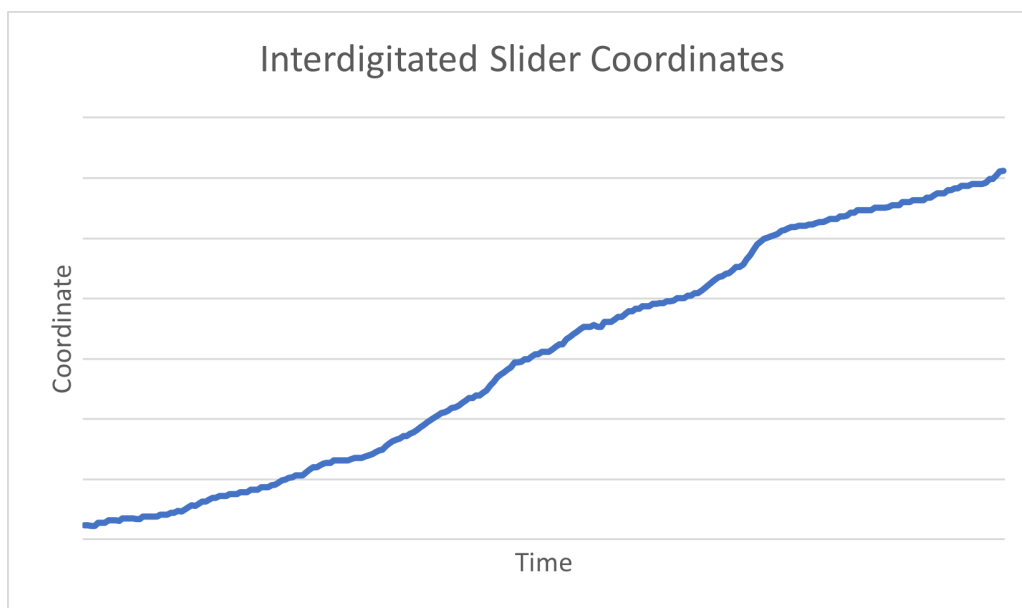

Figure 6.7: Interdigitated self-capacitive slider (Response)

6.1.2 Gap between Electrodes

Electrodes that are unused during the cycle are grounded. A slider with rectangular electrodes must have a gap between them of 0.25 - 0.5 mm. A gap smaller than 0.25mm may cause excessive load capacitance to the adjacent electrode. A small gap between electrodes allows a smooth signal transition from one channel to the next channel.

6.1.3 Layout Guidelines

This section provides example layout patterns with minimum, typical, and maximum dimensions to design a self-capacitive slider and wheel.

The corners of the rectangular electrodes are rounded to minimize susceptibility to ESD.

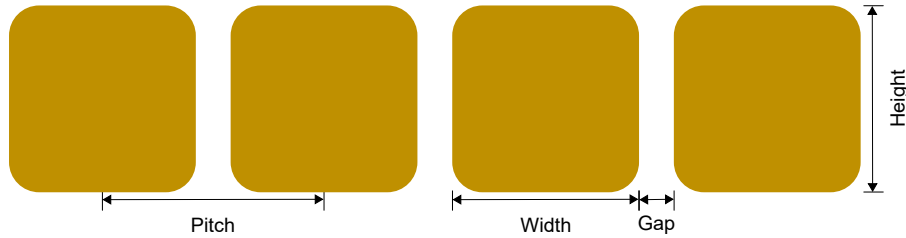

Parameter	Minimum	Typical	Maximum
Height	3.6 mm	8 mm	16 mm
Width	3.35 mm	4.5 mm	7 mm
Pitch	3.6 mm	5 mm	8 mm
Gap	0.25 mm	0.5 mm	1 mm
Number of Elements	3	3 or 4	8

Table 6.1: Rectangular Slider Parameters

A slider with interdigitated electrodes has longer edges running in parallel which leads to higher load (parasitic) capacitance to adjacent electrodes. Therefore, larger gaps between these electrodes are necessary. The small rectangular areas added to the slider on the left and right endings are referred to as padding. Padding helps to reach the starting and end coordinates, for example, 0 and 255. The tips of the fingers should be round-ended if there is a big risk of ESD in the application.

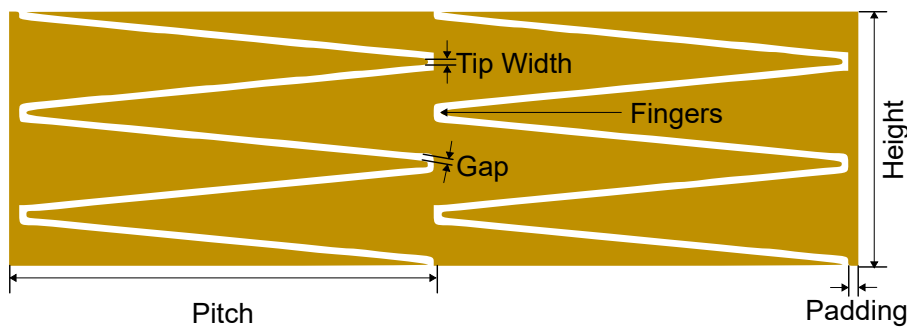

Parameter	Minimum	Typical	Maximum
Height	8 mm	12 mm	20 mm
Pitch	8 mm	16 mm	28 mm
Gap	0.5 mm	1 mm	1.5 mm
Padding	1 mm	2 mm	3.5 mm
Tip Width	0.25 mm	0.5 mm	1 mm
Number of Fingers	3	5	7
Number of Elements	3	3 or 4	8

Table 6.2: Interdigitated Slider Parameters

6.2 Mutual Capacitive Sliders and Wheels

Mutual capacitive sliders and wheels make use of a pair of electrodes to measure the capacitance between them. A user's touch reduces the capacitance between these electrodes by reducing the amount of charge transferred from the Tx electrode to the Rx electrode. Similar to a self-capacitive slider, a mutual capacitance slider can be created by placing a row of Rx electrodes close to each other. The difference with mutual capacitance is that an extra Tx electrode is added. The same is applied to the mutual capacitive wheel, where a Tx electrode is added to the wheel containing Rx electrodes. Typically, 3 or 4 elements in a slider or wheel are necessary to get optimal performance. The measured signals on the channels are used to calculate a touch coordinate. Coordinate linearity can be improved by interdigitated sensor electrodes.

While mutual capacitive sliders and wheels are possible and they do offer certain benefits, such as better moisture rejection and reduced EM crosstalk, over self-capacitive sliders and wheels, it is often easier to design self-capacitive wheels, as well as offer better conducted immunity.

Below are some examples of mutual capacitive sliders and wheels.

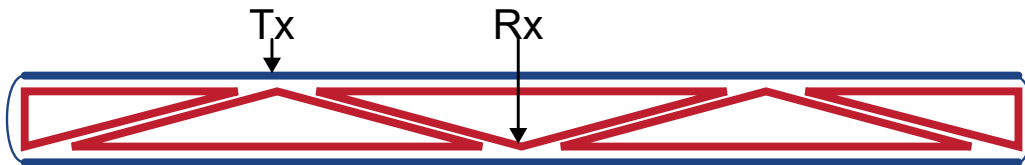

Figure 6.8: Example mutual capacitive slider design

The mutual capacitive slider consists of multiple Rx electrodes surrounded by a Tx electrode.

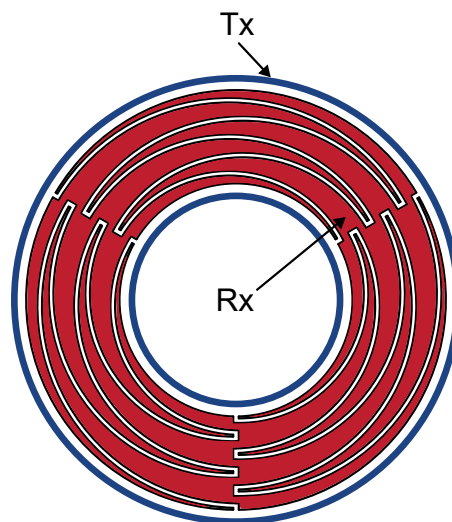

Figure 6.9: Example mutual capacitive wheel design 1

The mutual capacitive wheel in figure 6.9 is made up of multiple Rx electrodes, similar to the self-capacitive wheel, surrounded by a Tx electrode.

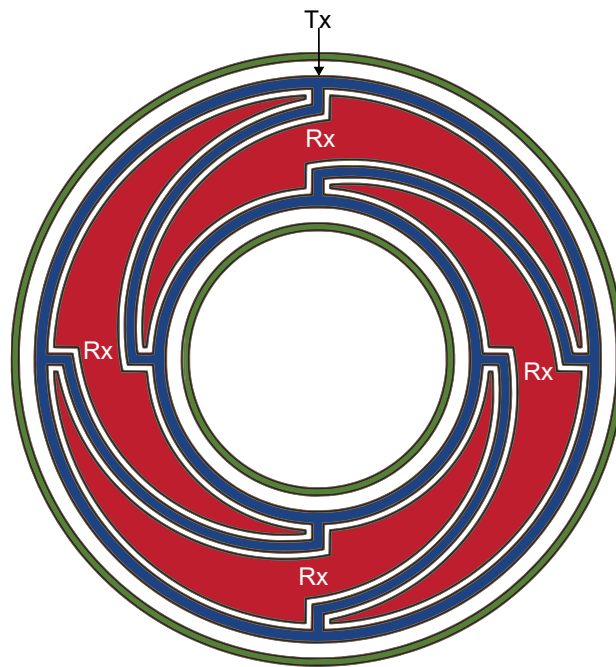

Figure 6.10: Example mutual capacitive wheel design 2

Figure 6.10 shows a design for the mutual capacitive wheel where the Tx electrode and Rx electrodes are interdigitated in the wheel.



7 Temperature Effects

7.1 General

A temperature change can impact the capacitive sensor measurements. Our ICs can track the drift in temperature and automatically tune the device to maintain sensitivity when the device is not in touch. Please refer to Section 7.2 for 'in-touch' temperature tracking.

User interface settings can be optimised for temperature shock or maximized proximity detection. Additional UIs and layout techniques are required to handle shock events while maintaining high sensitivity.

Substrate materials' thermo-dynamic properties play a significant role. As seen in section 3.1.4, thin FPC designs have high-temperature dependency, while LDS technology offers low-temperature stability.

7.2 Follow UI Setup

Some ICs offer a functionality called *Follow UI*, which allows for long-term 'in-touch' tracking. An example application for this functionality is wear detection, where a device is being worn for extended periods, requiring continuous capacitive sensing. This section will provide a brief explanation of how to set up this functionality, starting with the electrode configuration.

7.2.1 Electrode Configuration

In its simplest form, the Follow UI system requires a *sensing* and a *reference* electrode, where both function independently as self-capacitance electrodes. As the name suggests, the purpose of the sensing electrode is to detect user interaction with the device and should therefore be designed to be sensitive to human presence. The reference electrode, however, should be designed such that:

- > It is not affected by user interaction.
- > It is subject to the same temperature changes experienced by the sensing electrode.

The latter requirements may be achieved by using the following guidelines:

- > The reference electrode must be smaller in size than the sensing electrode. This will ensure that the reference electrode remains insensitive to human interaction. It is typical for the reference electrode to be a PCB trace with a width of 0.2 mm. To avoid a too-sensitive reference electrode, its width should be equal to or less than half of the thickness of the overlay. Refer to Figure 7.1 for an illustration.

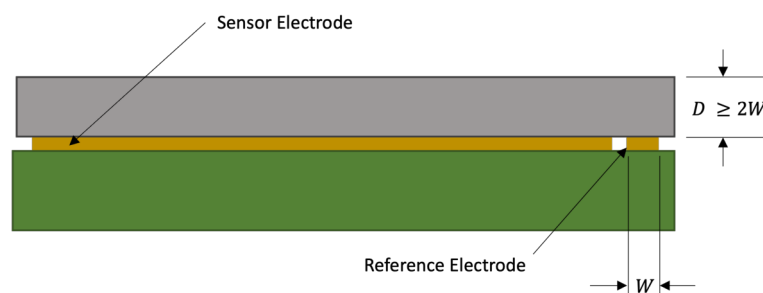

Figure 7.1: Illustration of the approximate width sizing of the reference electrode

- > The reference electrode should be placed such that it spans the same region as the sensing



electrode. This will ensure that temperature changes over the entire sensing region will be detected by the reference electrode. Refer to Figure 7.2 for a simple example of how the reference electrode may be routed to cover the sensing region.

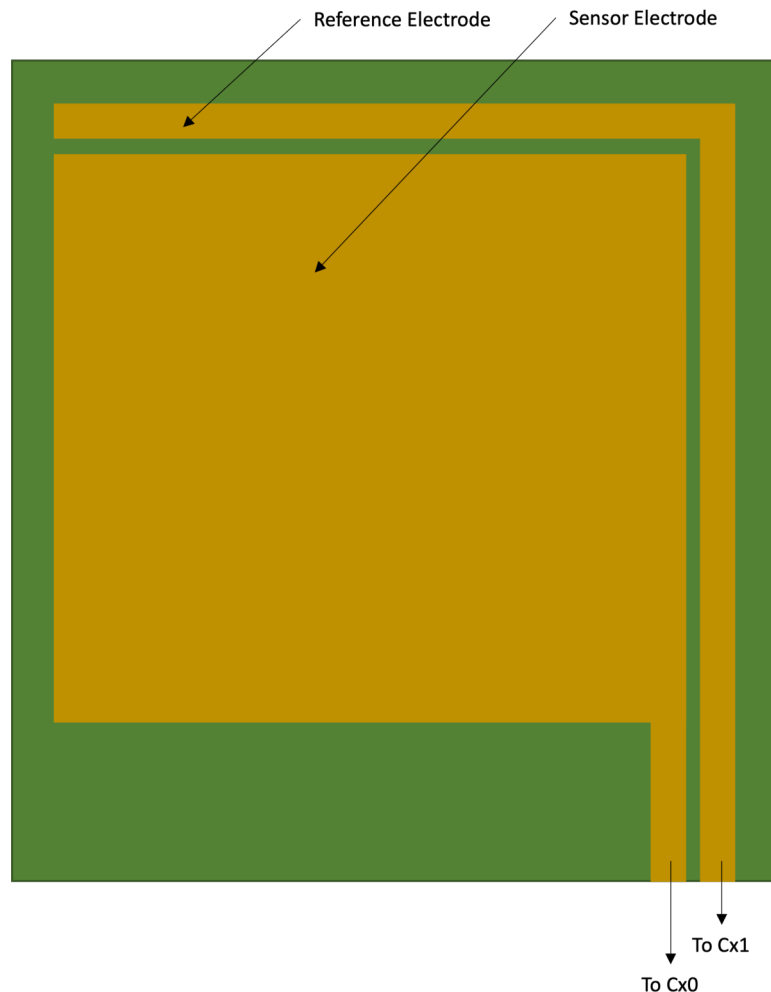

Figure 7.2: Illustration of the approximate PCB coverage of the reference electrode

- > The sensor and reference electrodes must be connected to separate Cx pins, and must have separate channels. For example, the sensor electrode may be connected to Cx0 and assigned to Channel 0, while the reference electrode is connected to Cx1 and assigned to Channel 1.

7.2.2 GUI Configuration

The exact GUI configuration procedure will depend on the IQS device being used, but generally, there are four main steps to be performed when configuring the Follow UI:

- > **Appoint a Follower Channel.** First, one of the channels needs to be designated as a follower. The channel of the sensor electrode must be selected as the **Follower**.
- > **Appoint a Reference / Leader Channel.** Next, the channel that is used for the reference electrode must be selected as the **Reference** or **Leader**.
- > **Select a Follow Event.** The event that will trigger the following action must also be selected. This may be when a specific channel goes into a proximity or touch state.
- > **Adjust the Follow Weight.** The follow weight is a numeric value that determines how aggressively the follower channel will follow the reference/leader channel. The method to determine



the follow weight is explained in Section 7.2.3.

Note that the above list is only a general list of actions required to enable the Follow UI. Please refer to the applicable IQS device's application note, datasheet or setup guide for detailed instructions.

7.2.3 How to Determine the Follow Weight

The following steps may be taken to determine the correct follow weight for your application.

1. Perform a Temperature Characterisation Test.

The first step is to determine the temperature response of the application within the desired operating temperatures. This will require an environment within which the temperature can be reliably controlled. It is required to choose a *Reference Environmental Temperature* (T_{ref}) at which the electrodes are calibrated before the test. Typically, the reference temperature $T_{ref} = 25\text{ }^{\circ}\text{C}$. Also, make sure of the following:

- > Both the sensor and reference channels are activated. This can be confirmed by monitoring their respective counts values in the Azoteq GUI.
- > Both the sensor and reference channels have completed their ATI procedure at T_{ref} . When this is completed, the ATI for both the Sensor and Reference channel should then be disabled.
- > The channels may not be in activation state.
- > Optionally, using the logging function in the GUI can help with the post-processing of the test results.

Now, change the temperature of the environment to the maximum (T_{max}) or minimum (T_{min}) operating temperature, and take note of the counts values of both the sensor and reference channels as they reach this temperature. It is expected that the counts values of the sensor and reference channels will have increased or decreased with the change in temperature.

2. Calculate the Follow Weight

By using the results from the temperature characterisation test, the follow weight W_f (in percentage) can be calculated using the following formula:

$$W_f = \frac{|N_{s,i} - N_{s,f}|}{|N_{r,i} - N_{r,f}|} \times 100, \quad (2)$$

where:

- > $N_{s,i}$ is the counts value of the sensor channel at T_{ref}
- > $N_{s,f}$ is the counts value of the sensor channel at T_{max} or T_{min} ,
- > $N_{r,i}$ is the counts value of the reference channel at T_{ref} and,
- > $N_{r,f}$ is the counts value of the reference channel at T_{max} or T_{min} .

3. Validate the Follow Weight

To validate the correctness of the follow weight, repeat the temperature test from Step 1, while the sensor channel is in activation or proximity state (or whichever condition is required for the sensor channel to initiate the following sequence.) During this test, it should be observed that the counts delta at T_{ref} and T_{min} or T_{max} should be the same. If this is not the case, then slight adjustments must be made to the follow weight until this is true.



7.2.4 Example Illustration of Follow Weight Calculation

To demonstrate the procedure of how to determine the follow weight value, an example will now be given.

For this example, we will use the electrode shown in Figure 7.2, which has a sensor electrode connected to Cx0 and a reference electrode connected to Cx1. We will assume that this PCB is already built into a watch device as the application. In the Azoteq GUI, we assign the sensor electrode to Channel 0, and the reference electrode to Channel 1. Then, Channel 0 is set as the follower channel, while Channel 1 is set as the reference channel. Since it is a watch application, we select the follow event as a touch state. Finally, we use the ATI to set Channel 0 to 1000 counts and Channel 1 to 700 counts, at room temperature (25 °C).

Note that the counts target used here for Channel 0 is higher than the value for Channel 1. This is an extra step of caution to ensure that the reference electrode does not detect user interaction. If Channel 1's counts target was also set at 1000, it would be more sensitive and there would be a slight chance that the reference channel can be influenced by the user. Thus, by setting it lower at a target of 700, we ensure that the reference channel remains isolated from the user.

We want the watch to be operational up to 50 °C, so we will perform a controlled temperature sweep on the watch from $T_{ref} = 25\text{ °C}$ up to $T_{max} = 50\text{ °C}$. Figure 7.3 below shows a typical result that may be observed in the 'SCOPE' view in the Azoteq GUI. For samples 0 to 100, the device was kept at 25 °C. Then, from samples 101 to 375, the device was heated to 50 °C, where it remained up to sample 500. It can be seen that both the sensor (blue) and reference (red) channel counts have decreased, but blue more so than red. It is this difference in rate of decrease that is captured by the follow weight, so that we may predict the LTA of the sensor channel by using the reference channel.

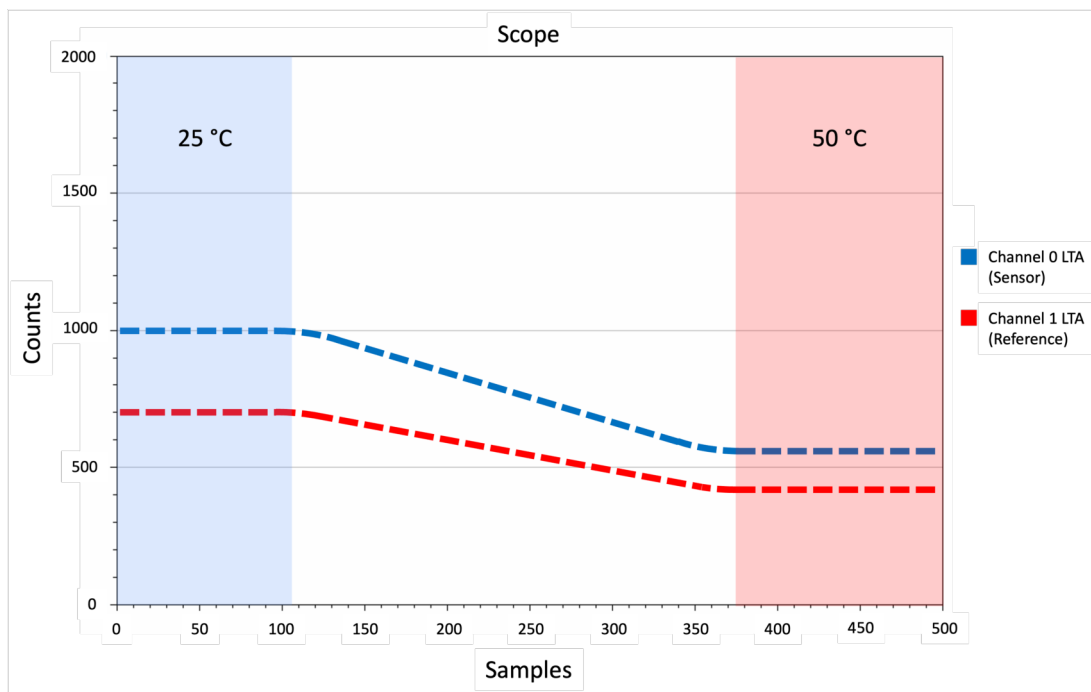

Figure 7.3: Example Scope View of a Device in a Temperature Characterisation Test



Using these results, we can calculate the follow weight W_f :

$$W_f = \frac{|1000 - 550|}{|700 - 400|} \times 100 = 150\%, \quad (3)$$

which means that for every 1 count change in the reference channel, we expect a 1.5 count change in the sensor channel within the tested operating range.

Finally, we must validate the follow weight for when there is a touch event. After applying the follow weight as determined in (3), the test is repeated, but with Channel 0 in touch. Figure 7.4 shows the desired result of the repeated test. At sample 50 the device is put in touch and it is seen how a counts delta is formed between the Channel 0 signal and LTA lines at $T_{ref} = 25^\circ\text{C}$.

Once again, at sample 100 the device is heated and here two LTAs are shown to demonstrate the effect of the Follow UI. The light blue line follows the signal drift to maintain the counts delta, and is controlled by the reference channel and the assigned follow weight. The green line is the LTA without the Follow UI, which will remain halted because of the touch event. At sample 450, at 50°C , the touch is removed and it is shown how Channel 0 recovers to the level of the LTA that followed, indicating a successful touch release. Without the Follow UI, the device would not have registered a released touch event, since the green line did not follow the temperature change. Lastly, according to the third point of Section 7.2.3, we must verify that the counts delta at T_{ref} and at T_{max} are the same, which is shown in Figure 7.4 to be true.

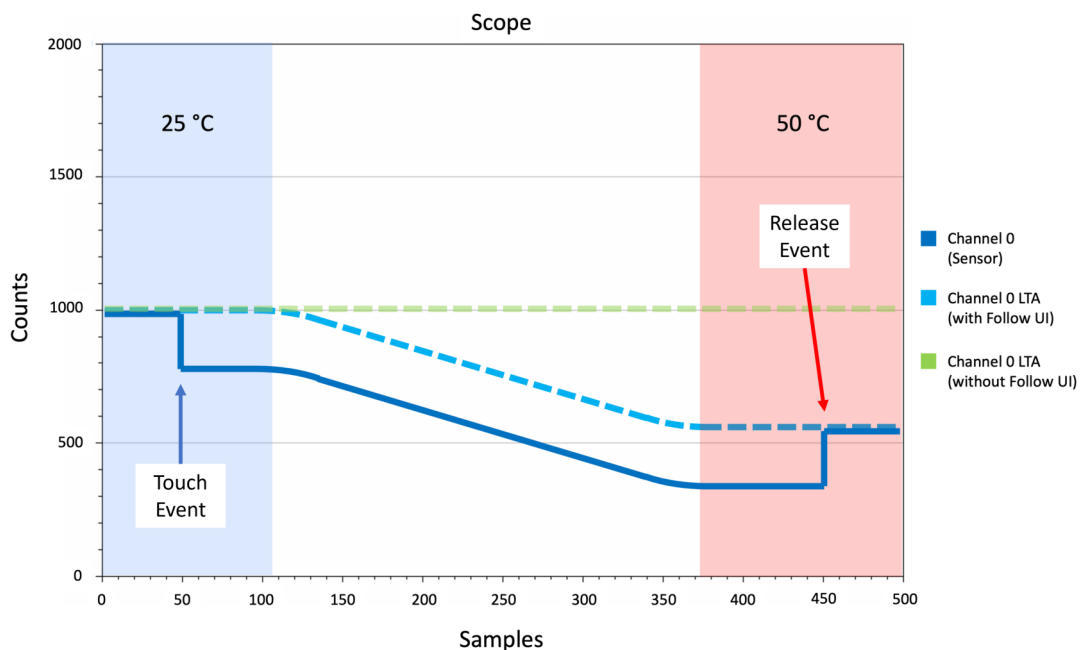

Figure 7.4: Example Scope View of a Device During the Validation Test

It should be noted that it is best to calculate the follow weight for several device samples before determining the final follow weight to account for production variation.



7.2.5 Follow Weight Troubleshooting

This section discusses some solutions to common anomalies that may arise during the follow weight setup process.

> **There is little or no drift occurring in the sensor channel.**

In this case, it is not necessary to use the Follow UI for the application. However, it is recommended that the 'no drift' result is confirmed on multiple samples before concluding that the system is drift resistant.

> **There is significant drift in the sensor channel, but no drift in the reference channel.**

The reference channel's sensitivity needs to be improved. This can be done by increasing its resolution factor, or the base value of the channel may be lowered slightly if the resolution factor increase alone is not sufficient. In the event that a lower base and a higher resolution factor do not work, the reference electrode itself must be redesigned to be larger or better positioned to observe the environmental changes. After these changes, it is important to verify that the reference channel is still immune to user interaction.

> **The sensor channel reaches a timeout state before reaching T_{min} or T_{max} .**

The sensor channel needs to be adjusted to be less sensitive. To achieve this, the resolution factor must be lowered. Then, re-run the test to verify that a timeout does not occur, and also verify that the sensor channel is still sensitive enough to detect the user.

8 Water Immunity and Humidity

The performance of capacitive touch sensing can be affected by the build-up of moisture or liquid spills on the sensing area. Moisture build-up or liquid spills affect the capacitive sensing electrode due to the liquid exhibiting electrical conductivity. This conductive property allows the moisture or liquid to affect the capacitive sensor similar to placing a conductor on the touch sensor. Moisture is also unpredictable as:

- > Its conductivity is variable
- > The shape and size of droplets are variable
- > Changes occur quickly, so it would appear more like a touch and less like an environmental change

To make a design moisture tolerant, the touch application can be installed in a vertical configuration (perpendicular to the earth) to allow accumulated moisture to naturally drip off due to gravity. There should not be an opportunity for moisture or liquids to pool on the touch pad. The following can be applied to make the capacitive touch design more tolerant to moisture:

- > There should be sufficient spacing between buttons
- > Provide enough spacing between the touch pad and ground
- > Route electrode traces away from the surface that might come into contact with moisture or liquid
- > Try using a non-conductive enclosure for the design

If a design is highly susceptible to moisture changes (typical for devices that are not waterproof) the effects can be reduced by using materials that are not sensitive to moisture like LDS (plastic printed sensing pads) on the reverse side of the area that is moisture sensitive.

The capacitive touch solution can be designed in such a way that a liquid pool on the touch panel can



be detected and the touch functionality disabled until the liquid pool is removed. This can be achieved by the use of a guard channel to detect large objects.

9 Noise

Very small signals, in the order of low femto-farads, are detected by the capacitive sensor. Due to the signals being so small relative to the parasitic capacitance, it is important to design for noise immunity to achieve optimal SNR. The following steps can be applied to improve the noise immunity of the design:

- > First, determine whether self or mutual capacitance will be used for the design.
- > Make sure the PCB layout adheres to the points in the hardware checklist below.
- > Once the product has been fabricated and the settings can be tuned, make sure that the device is tuned according to the tuning checklist.

Hardware Checklist

- > Limit the size of the electrodes, it should not be bigger than necessary.
- > Eliminate air gaps between the electrode and overlay.
- > Keep traces to the electrode as short as possible and route traces away from the touch area.
- > Use a dense return (ground) plane to limit fringe E-fields.
- > Avoid connectors when routing Rx and Tx.
- > Apply good power supply design principles.

Software Tuning Checklist

- > For mutual capacitive sensing, a conversion frequency of 1 MHz and above should be used.
- > Optimise the activation and release debounce values.
- > Optimise count filter beta to reduce noise.
- > Optimise threshold values to reduce false detections.



10 Revision History

Release	Date	Comments
v1.0	2022/11/25	Initial document released
v1.1	2023/08/15	Temperature Effects section updated



Contact Information

	USA	Asia	South Africa
Physical Address	11940 Jollyville Suite 120-S Austin TX 78759 USA	Room 501A, Block A T-Share International Centre Taoyuan Road, Nanshan District Shenzhen, Guangdong, PRC	1 Bergsig Avenue Paarl 7646 South Africa
Postal Address	11940 Jollyville Suite 120-S Austin TX 78759 USA	Room 501A, Block A T-Share International Centre Taoyuan Road, Nanshan District Shenzhen, Guangdong, PRC	PO Box 3534 Paarl 7620 South Africa
Tel	+1 512 538 1995	+86 755 8303 5294 ext 808	+27 21 863 0033
Email	info@azoteq.com	info@azoteq.com	info@azoteq.com

*Visit www.azoteq.com
for a list of distributors and worldwide representation.*

Patents as listed on www.azoteq.com/patents-trademarks/ may relate to the device or usage of the device.

Azoteq®, Crystal Driver®, IQ Switch®, ProxSense®, ProxFusion®, LightSense™, SwipeSwitch™, and the  logo are trademarks of Azoteq.

The information in this Datasheet is believed to be accurate at the time of publication. Azoteq uses reasonable effort to maintain the information up-to-date and accurate, but does not warrant the accuracy, completeness or reliability of the information contained herein. All content and information are provided on an “as is” basis only, without any representations or warranties, express or implied, of any kind, including representations about the suitability of these products or information for any purpose. Azoteq disclaims all warranties and conditions with regard to these products and information, including but not limited to all implied warranties and conditions of merchantability, fitness for a particular purpose, title and non-infringement of any third party intellectual property rights. Azoteq assumes no liability for any damages or injury arising from any use of the information or the product or caused by, without limitation, failure of performance, error, omission, interruption, defect, delay in operation or transmission, even if Azoteq has been advised of the possibility of such damages. The applications mentioned herein are used solely for the purpose of illustration and Azoteq makes no warranty or representation that such applications will be suitable without further modification, nor recommends the use of its products for application that may present a risk to human life due to malfunction or otherwise. Azoteq products are not authorized for use as critical components in life support devices or systems. No licenses to patents are granted, implicitly, express or implied, by estoppel or otherwise, under any intellectual property rights. In the event that any of the abovementioned limitations or exclusions does not apply, it is agreed that Azoteq’s total liability for all losses, damages and causes of action (in contract, tort (including without limitation, negligence) or otherwise) will not exceed the amount already paid by the customer for the products. Azoteq reserves the right to alter its products, to make corrections, deletions, modifications, enhancements, improvements and other changes to the content and information, its products, programs and services at any time or to move or discontinue any contents, products, programs or services without prior notification. For the most up-to-date information and binding Terms and Conditions please refer to www.azoteq.com.