



AZD073 – SAR qualification with Azoteq ProxSense® movement-based sensors

Azoteq movement-based sensors offer a unique combination of effective SAR compliance along with quick product integration and good user experience

1 Introduction

Azoteq SAR solutions are designed to adhere to the following standards:

- IEC 62209-2 ed1.0 standard
- FCC standard (KDB 616217 - D04 SAR for laptop and tablets v01)

The typical user interface is summarized in Figure 2 below.

Azoteq currently offers the following movement-based solutions:

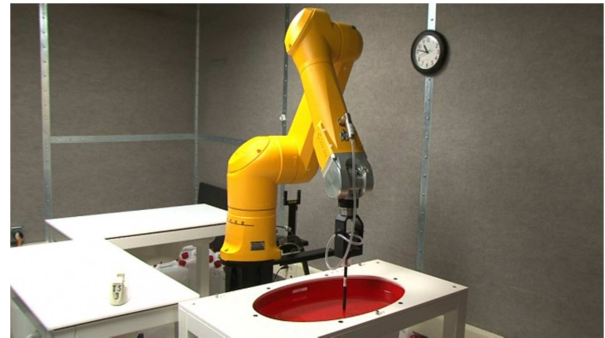

Figure 1 An example of the test instrumentation used for SAR qualification

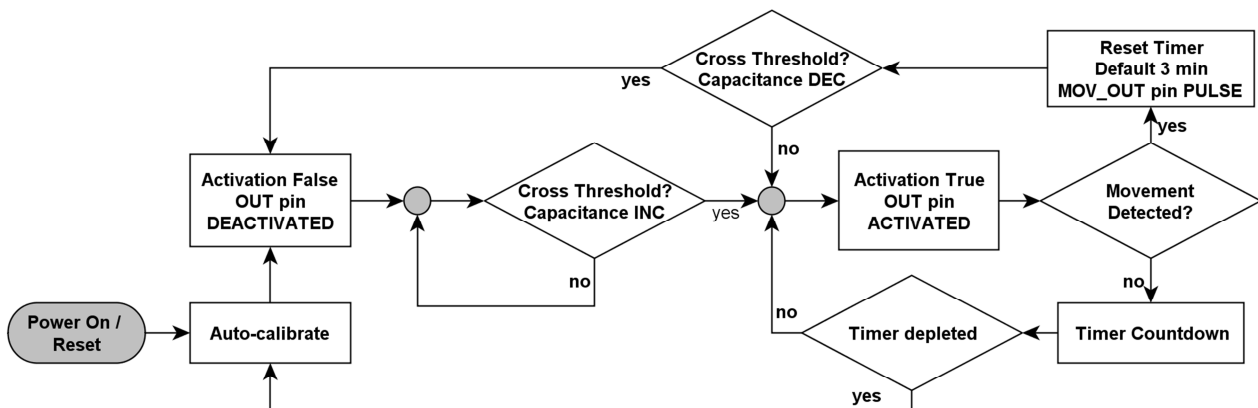

Figure 2 User interface flow diagram for the Azoteq movement based sensors

- IQS229 (see datasheet for a detailed explanation of all features)

2 Passing the SAR Test Specification

Azoteq SAR solutions are designed to pass the FCC SAR test specification as well as give an optimal user experience. The problem with non-adaptive capacitive sensors is their inability to effectively reject a non-human activation condition. Azoteq uses sophisticated hardware along with digital filtering in order to detect the

slightest human movements. This is used to provide effective recovery when a device is placed on or close to a surface with a high dielectric strength and good coupling to the DUT reference ground.

The following sections are aimed at enabling the designer to effectively pass the SAR test specification with the Azoteq ProxSense® movement-based sensors while maintaining an optimal user experience.



2.1 The inanimate phantom

The statistical probability of being inside activation threshold without any movement for a selectable period of time (maximum 10 minutes) is highly improbable, but still possible. This is especially true with the flat-phantom used for SAR testing.

If such possibility is still a concern, Azoteq make it possible to distinguish between a threshold release and a no-movement release as shown in Figure 3.

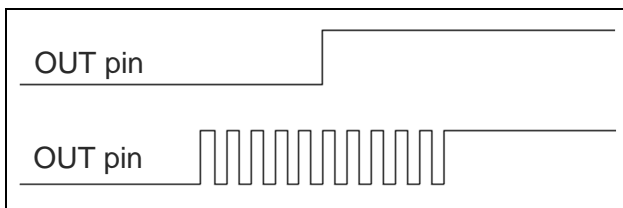

Figure 3 Normal release with threshold crossing (top), time-out release with no-movement condition (bottom)

The operating system may therefore choose to extend the Azoteq maximum period of 10 minutes to whatever is best suited for the application and SAR test requirements.

2.2 An alternative approach

In addition, the designer is given direct access to the separate movement indication output that may be used to solve the SAR compliance in a completely different way. By monitoring the movement the designer may define a unique response to adhere to SAR limits and comply with FCC SAR test specifications.

2.3 Adaption of test procedures

From the FCC SAR test specification for tablets and laptops it is clear that existing proximity sensors are typically triggered by capacitance changes due to objects in the vicinity of the sensing element. If similar but different sensor triggering implementations are used, the test procedures may be adapted for such designs with justification included in the test documentation. Otherwise, a KDB (FCC Knowledge Database) inquiry on the FCC electronic

filing system is required to determine the test requirements.

2.4 Failsafe implementation

When using the activation output pin, Azoteq ensures a safe default power level through a series of failsafe implementations:

- Active low with pull-down resistor ensures activation with failure (at the cost of leakage current with no activation)
- Hard reset by pulling the movement pin low. This allows for a restart and device status check.
- Characteristic toggle on output pin with power-up and with hard reset to check if the IC is properly functioning.

2.5 Advantage of dedicated test software

From FCC documentation, the proximity triggers may be tested by monitoring the RF power levels directly (access to antenna ports inside required). Otherwise test software may be run to report the proximity sensor triggers, with the RF power level switching confirmed separately. The second option is ideal when the connection to the antenna port may influence the proximity sensor performance.

It is therefore recommended to allow for test software that reports the state of the sensor.

2.6 Test procedure for determining the trigger distance

A typical activation distance evaluation curve is shown in Figure 4. It is important to note that the initial 3mm movements will cause greater movement detections than 1mm movements. It is recommended to have an electrode design that is sensitive to 3mm and 1mm movements in relation to a typical flat phantom, but if this is an issue because of restricted electrode size, a KDB inquiry should be submitted to determine alternative test configurations.



The entire test should be done in one of the following ways to comply with Azoteq's movement based sensor:

1. Include movements at 1mm/second with a maximum time of 10 minutes between movements. When movements are too slow, temperature compensation algorithms will start to have an effect.

For more information on SAR test requirements please view the FCC document, "KDB 616217 - D04 SAR for laptop and tablets v01".

2.8 Power-up sensing accuracy

Capacitive sensors generally measure extremely small capacitive changes when detecting proximity. In order to be sensitive

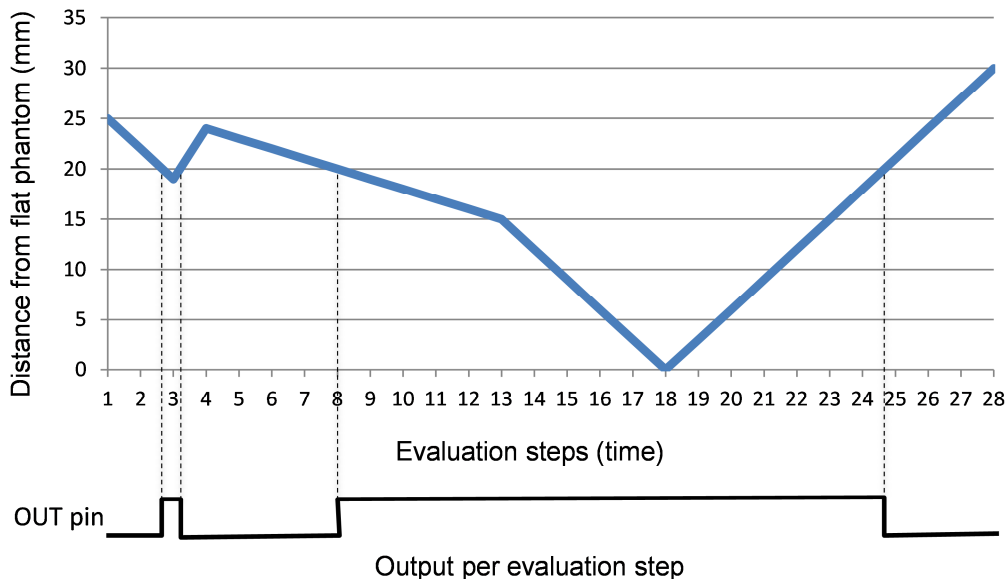

Figure 4 FCC procedure for activation distance detection

2. The threshold for activation is not dependant on movement; therefore movement will never impact the threshold-based operation except for delaying the auto-release. As long as the time inside activation is less than the Azoteq maximum of 10 minutes or less than a custom time-out defined by the operating system (as discussed in section 2.1). The activation will trigger a timer and this timer will time-out after a maximum of 10 minutes before releasing the activation.

2.7 SAR qualification confidence

Azoteq movement based SAR sensors coupled with a well-integrated electrode will pass the SAR test with minimal added test specifications, while ensuring optimal user experience by offering a practical non-human activation resolve when the device is placed on an inanimate object.

for a specific environment, the sensor will calibrate automatically after power-up. The sensor will then track temperature changes and other environmental changes in order to remain sensitive to proximity events at any specific time.

The sensor may be left to calibrate at power-up if the specific SAR qualification tests do not involve a power-up test with the device against the phantom.

If the qualification does include such a test, the test may be passed in one of the following ways:

1. Connect the sensor before the on/off switch and therefore keep the device powered on for its lifetime. The algorithm and therefore the outputs are designed to be stable over the long term. As reference, the IQS229 will only drain a 1000mAh battery in more than 3 years at 30µA. In other words the current consumption of the IQS229 is



much less than the typical battery leakage current.

2. A KDB (FCC Knowledge Database) inquiry can be made to argue and prove an increase in movement sensitivity when the device is powered-up next to the phantom. In addition to this, the reference for the activation threshold will adapt very quickly with the slightest back-off away from the phantom. The slightest back-off followed by re-entry to the same position will be able to trigger the activation in this power-up scenario. It may be argued that this would be typical human behavior within predefined SAR time limits.

2.9 Detection distance

It is important to implement a good electrode design. Follow the general guidelines for the electrode design as shown in [application note AZD008](#). In addition be sure to keep the following in mind:

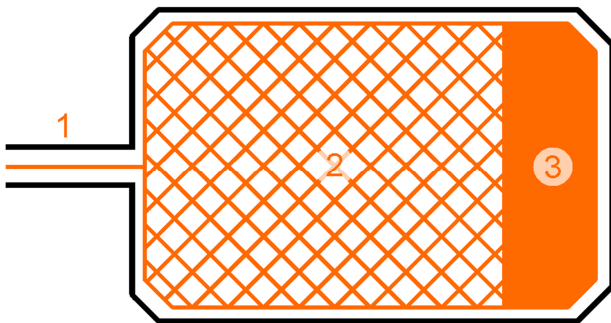

1. **Minimize load capacitance:** Use thin tracks in areas where sensing is not required or where capacitive loads from the battery or metal structures cannot be avoided.
2. **Cover the area of interest without overloading sensor:** Use hatched pours (decrease copper while maintaining area) when sensing is required over large areas. This decreases the load capacitance and possible variable elements that may cause false triggers.
3. **Focus the sensing in certain critical parts:** Use solid pours in smaller areas

and where detection distance is most important.

4. **Remove air-gaps:** It is best to place or glue an electrode right against the area of interest. Therefore it is best to have an FPC off the main PCB to obtain optimal detection distance.

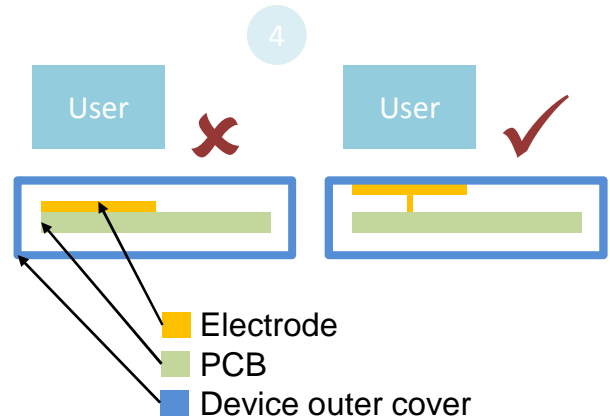

5. **Avoid placing electrode near large conductive areas:** This may cause significant changes in capacitance or it may cause decreased sensitivity in the intended sensing area place.

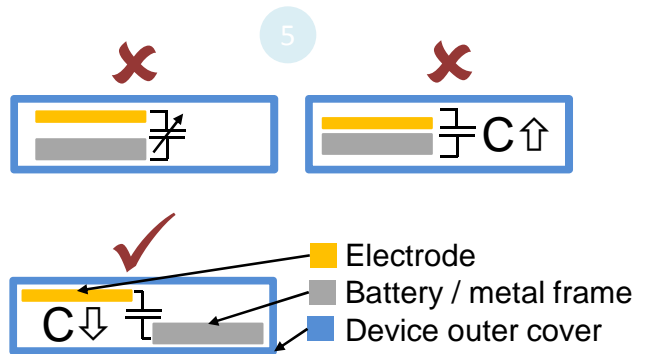



Appendix A. Contact Information

	USA	Asia	South Africa
Physical Address	6507 Jester Blvd Bldg 5, suite 510G Austin TX 78750 USA	Rm1725, Glittery City Shennan Rd Futian District Shenzhen, 518033 China	109 Main Street Paarl 7646 South Africa
Postal Address	6507 Jester Blvd Bldg 5, suite 510G Austin TX 78750 USA	Rm1725, Glittery City Shennan Rd Futian District Shenzhen, 518033 China	PO Box 3534 Paarl 7620 South Africa
Tel	+1 512 538 1995	+86 755 8303 5294 ext 808	+27 21 863 0033
Fax	+1 512 672 8442		+27 21 863 1512
Email	kobusm@azoteq.com	linayu@azoteq.com.cn	info@azoteq.com

Please visit www.azoteq.com for a list of distributors and worldwide representation.

The following patents relate to the device or usage of the device: US 6,249,089 B1, US 6,952,084 B2, US 6,984,900 B1, US 7,084,526 B2, US 7,084,531 B2, EP 1 120 018 B2, EP 1 206 168 B1, EP 1 308 913 B1, EP 1 530 178 A1, ZL 99 8 14357.X, AUS 761094, HK 104 14100A, US13/644,558, US13/873,418

IQ Switch®, SwipeSwitch™, ProxSense®, LightSense™, AirButton® and the  logo are trademarks of Azoteq.

The information in this Datasheet is believed to be accurate at the time of publication. Azoteq uses reasonable effort to maintain the information up-to-date and accurate, but does not warrant the accuracy, completeness or reliability of the information contained herein. All content and information are provided on a "as is" basis only, without any representations or warranties, express or implied, of any kind, including representations about the suitability of these products or information for any purpose. Azoteq disclaims all warranties and conditions with regard to these products and information, including but not limited to all implied warranties and conditions of merchantability, fitness for a particular purpose, title and non-infringement of any third party intellectual property rights. Azoteq assumes no liability for any damages or injury arising from any use of the information or the product or caused by, without limitation, failure of performance, error, omission, interruption, defect, delay in operation or transmission, even if Azoteq has been advised of the possibility of such damages. The applications mentioned herein are used solely for the purpose of illustration and Azoteq makes no warranty or representation that such applications will be suitable without further modification, nor recommends the use of its products for application that may present a risk to human life due to malfunction or otherwise. Azoteq products are not authorized for use as critical components in life support devices or systems. No licenses to patents are granted, implicitly, express or implied, by estoppel or otherwise, under any intellectual property rights. In the event that any of the abovementioned limitations or exclusions does not apply, it is agreed that Azoteq's total liability for all losses, damages and causes of action (in contract, tort (including without limitation, negligence) or otherwise) will not exceed the amount already paid by the customer for the products. Azoteq reserves the right to alter its products, to make corrections, deletions, modifications, enhancements, improvements and other changes to the content and information, its products, programs and services at any time or to move or discontinue any contents, products, programs or services without prior notification. For the most up-to-date information and binding Terms and Conditions please refer to www.azoteq.com.

WWW.AZOTEQ.COM

info@azoteq.com