



AZD026 – AZOTEQ USB-DONGLE OVERVIEW

Azoteq provides software used for serial streaming of data to a computer by utilising the Azoteq USB-dongles. Each IC has dedicated software which is intended for prototyping purposes.

Table of Contents

AZD026 – AZOTEQ USB DONGLE OVERVIEW.....	1
1 AZOTEQ USB-DONGLE USAGE.....	2
2 CONNECTING USB-DONGLE FOR <i>PROGRAMMING</i>	4
3 CONNECTING USB-DONGLE FOR <i>SERIAL COMMUNICATION</i>	7
4 FLASH PROGRAMMING (CT210/CT210A).....	9
5 BOOTLOADER PROGRAMMING (CT210/CT210A/DS100).....	10
6 REVISION HISTORY.....	11



1 Azoteq USB-dongle Usage

The Azoteq USB-dongles available for commercial use are listed in Table 1. The dongles are connected to a computer via a mini-USB (micro-USB for CT210A) cable and are used:

(Please Note: Use with USB data cable only)

- As an interface to program OTP¹ bits which are available on certain ICs (to customize an IC for a certain design), see tables Table 2 and Table 3 for pin assignment or
- to perform serial communication between the computer and IC via
 - 1-wire Communication Protocol (Table 5)
 - SPI (Table 6)
 - I²C (Table 7)
- Flash programming (Table 8)
- Bootloader programming (Table 9)

Azoteq provides the software necessary for programming OTP bits. This software is known as USBProg which is intended for prototyping purposes. More information regarding USBProg can be found in application note AZD007.

Azoteq provides software used for serial streaming of data to a computer by utilising the Azoteq USB-dongles. Each IC has dedicated software which is intended for prototyping purposes. The software is available on the Azoteq website under Software and Tools.

Table 1 Azoteq USB-dongles

Azoteq dongle	Description	Device Supported	Data Streaming	Programming	Boot loading
CT210A	4 th Generation programmer and data streamer	ALL	✓	✓	✓
CT210	3 rd Generation programmer and data streamer	ALL	✓	✓	✓
DS100	Data Streaming Dongle	ALL	✓	✗	✓

¹ One Time Programmable bit – Every bit is only programmable once



1.1 Azoteq USB-dongle Pin-layout

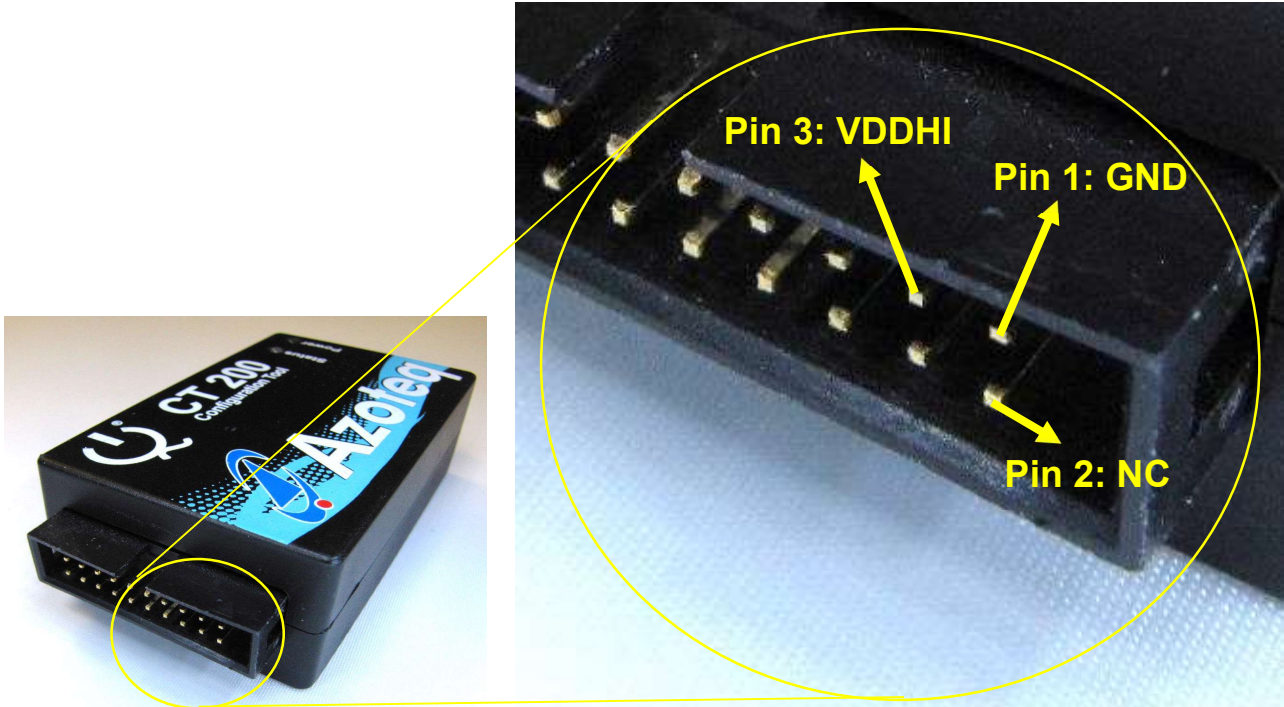

Figure 1 Pin layout



2 Connecting USB-dongle for Programming

Table 2 Azoteq USB-dongle Pin Assignment for Programming IC's

CT pin #	IQS127/ IQS128	IQS133	IQS213A/ IQS263B	IQS266	IQS269A	IQS333/ IQS360(A)	IQS62x/ IQS680
1	V _{SS}	V _{SS}	V _{SS}	V _{SS}	V _{SS}	V _{SS}	V _{SS}
2							
3	V _{DDHI}	V _{DDHI}	V _{DDHI}	V _{DDHI}	V _{DDHI}	V _{DDHI}	V _{DDHI}
4							
5	SHLD/POUT		RDY	TX1	RDY	PWM3	LTX/LED0/OUTPUT
6	CX						
7		TO0/DATA	SDA	SDA	SDA	SDA	SDA
8							
9		TO1	SCL	SCL	SCL	SCL	SCL
10							

Only devices with OTP bits are shown



Table 3 Azoteq USB-dongle Pin Assignment for Programming with a Special Connection

CT pin #	IQS227AS/IQS228AS IQS211(A)/IQS231(A)
1	V _{SS}
2	
3	V _{DDHI}
4	
5	IO1 / SCL (diode required – see picture)
6	
7	IO2 / SDA
8	
9	IO1 / SCL
10	

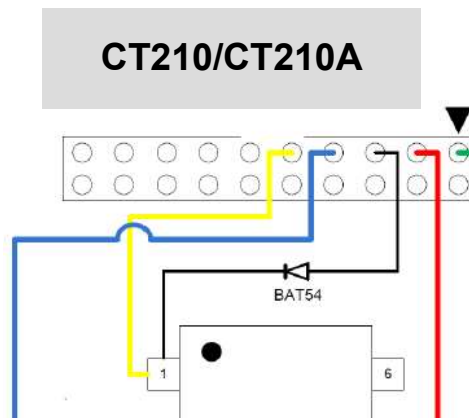

Table 4 Azoteq USB-dongle Pin Assignment for Programming IQS333 OTP Using Azoteq USBProg

CT pin #	IQS333
1	V _{SS}
2	
3	V _{DDHI}
4	
5	PWM3
6	
7	SDA
8	
9	SCL
10	RDY



Note: Ensure that V_{DDHI} and V_{REG} capacitors are connected as specified by the relevant datasheet for all programming.



3 Connecting USB-dongle for *Serial Communication*

Please refer to the datasheet and communication interface of the specific device for information regarding the communication protocol supported.

3.1 1-wire Protocol

Table 5 Azoteq USB-dongle Pin Assignment for 1-wire Protocol

USB-dongle pin #	Azoteq 1-wire device
1	V _{SS}
2	
3 ²	V _{DDHI}
4	
...	
9	
10	DATA

3.2 SPI

Table 6 Azoteq USB-dongle Pin Assignment for SPI

USB-dongle pin #	Azoteq SPI Device
1	V _{SS}
2	
3	V _{DDHI}
4	
5	
6	MOSI
7	SOMI
8	RDY
9	SCK
10	/SS

² VDDHI can be supplied by an external source, please ensure that the same voltage levels as USB-dongle are followed



3.3 I²C

Table 7 Azoteq USB-dongle Pin Assignment for I2C

USB-dongle pin #	Azoteq I ² C Device
1	V _{SS}
2	
3	V _{DDHI}
4	
5	
6	
7	I2C SDA
8	
9	I2C SCL
10	RDY



4 Flash Programming (CT210/CT210A)

The CT210/CT210A supports a programming protocol used to program certain flash MCU's (e.g. IQS550, IQS572, and IQS525). The dedicated software for flash programming is Azoteq Flash Programmer. The pinout to perform flash programming can be seen in Table 8.

Table 8 Azoteq USB-dongle Pin Assignment for Flash Programming

CT pin #	Flash MCU
1	V _{SS}
2	
3	V _{DDHI}
..	
..	
..	
17	RESET/NRST
18	DATA/PGM
19	
20	



5 Bootloader Programming (CT210/CT210A/DS100)

The CT210/CT210A/DS100 also supports programming via a bootloader on-chip for the IQS550, IQS572 and IQS525 ICs. The dedicated software for bootloader programming is Azoteq Flash Programmer. The pinout to perform bootloader programming can be seen in Table 9.

Table 9 Azoteq USB-dongle Pin Assignment for Bootloader Programming

USB-dongle pin #	Azoteq I ² C Device
1	V _{SS}
2	
3	V _{DDHI}
4	
5	
6	
7	I2C SDA
8	
9	I2C SCL
10	



6 Revision History

Version	Release date	Change Notes
0.05	March 2011	Initial release
0.06	May 2012	An updated list of supported Azoteq USB dongles Added 2-series ICs (232/233/242/252) Consolidated 1-wire protocol Added CT220/CT210 Flash Programming pin connections
0.07	November 2015	Reformatted document to the latest Azoteq template Updated to reflect the current state of the CT210 and what devices are not supported anymore. Added programming with special connections for the IQS227AS, IQS228AS, IQS211, IQS231 Added I2C Boot loader programming pinout connections, section 5
0.08	April 2017	Added CT210A
0.09	August 2017	Added IQS333 I2C OTP
0.10	November 2017	Added: Use with USB data cable only Removed EOL items
0.11	January 2019	Corrected Table 2.1
0.12	April 2020	Various updates



Contact Information

	USA	Asia	South Africa
Physical Address	11940 Jollyville Suite 120-S Austin TX 78759 USA	Room 501A, Block A, T-Share International Centre, Taoyuan Road, Nanshan District, Shenzhen, Guangdong, PRC	1 Bergsig Avenue Paarl 7646 South Africa
Postal Address	11940 Jollyville Suite 120-S Austin TX 78759 USA	Room 501A, Block A, T-Share International Centre, Taoyuan Road, Nanshan District, Shenzhen, Guangdong, PRC	PO Box 3534 Paarl 7620 South Africa
Tel	+1 512 538 1995	+86 755 8303 5294 ext 808	+27 21 863 0033
Email	info@azoteq.com	info@azoteq.com	info@azoteq.com

Visit www.azoteq.com

for a list of distributors and worldwide representation.

Patents as listed on www.azoteq.com/patents-trademarks/ may relate to the device or usage of the device.

Azoteq®, Crystal Driver®, IQ Switch®, ProxSense®, ProxFusion®, LightSense™, SwipeSwitch™, and the  logo are trademarks of Azoteq.

The information in this Datasheet is believed to be accurate at the time of publication. Azoteq uses reasonable effort to maintain the information up-to-date and accurate, but does not warrant the accuracy, completeness or reliability of the information contained herein. All content and information are provided on an “as is” basis only, without any representations or warranties, express or implied, of any kind, including representations about the suitability of these products or information for any purpose. Azoteq disclaims all warranties and conditions with regard to these products and information, including but not limited to all implied warranties and conditions of merchantability, fitness for a particular purpose, title and non-infringement of any third party intellectual property rights. Azoteq assumes no liability for any damages or injury arising from any use of the information or the product or caused by, without limitation, failure of performance, error, omission, interruption, defect, delay in operation or transmission, even if Azoteq has been advised of the possibility of such damages. The applications mentioned herein are used solely for the purpose of illustration and Azoteq makes no warranty or representation that such applications will be suitable without further modification, nor recommends the use of its products for application that may present a risk to human life due to malfunction or otherwise. Azoteq products are not authorized for use as critical components in life support devices or systems. No licenses to patents are granted, implicitly, express or implied, by estoppel or otherwise, under any intellectual property rights. In the event that any of the abovementioned limitations or exclusions does not apply, it is agreed that Azoteq’s total liability for all losses, damages and causes of action (in contract, tort (including without limitation, negligence) or otherwise) will not exceed the amount already paid by the customer for the products. Azoteq reserves the right to alter its products, to make corrections, deletions, modifications, enhancements, improvements and other changes to the content and information, its products, programs and services at any time or to move or discontinue any contents, products, programs or services without prior notification. For the most up-to-date information and binding Terms and Conditions please refer to www.azoteq.com.