



IQS324 Datasheet

Off-Axis Hall-Rotation Sensor With Adjustable Interval UI and Inductive/Capacitive ProxFusion® Channel.

1 Device Overview

The IQS324 ProxFusion® IC is a sensor fusion device for rotation and angle sensing applications using a diametrically-polarised magnet in an off-axis configuration. The included ProxFusion® channel can be used for integrated UI applications or as a wake-up channel.

1.1 Main Features

- > Highly Flexible ProxFusion® Device
- > Hall-Effect Angle Sensor
 - 4 Hall plates
 - Off-axis orientation
 - 16-bit absolute angle output
 - <1° angle errorⁱ
 - Wide operational range
 - Automatic Tuning Implementation (ATI)
 - Automatic synchronisation with mechanical ratchets
- > ProxFusion® Channel
 - Supports self-capacitive or inductive sensing
 - Automatic Tuning Implementation (ATI)
 - Button UI to detect large changes
 - Movement UI to detect small/rapid changes
- > Interval UI
 - Configurable number of intervals per rotation
 - Configurable hysteresis between intervals
- > I²C Interface With IRQ/RDY Signal
- > Design Simplicity
 - PC software for configuration and debugging
 - Guidelines for magnet selection and mechanical constraints
- > Supply Voltage: 1.8 V to 3.6 V
- > QFN20 Package (3 × 3 × 0.5 mm) – 0.4 mm pitch



QFN20 Package

1.2 Applications

- > Scroll wheels and thumb wheels for computer peripherals
- > Applications requiring flexible UI options with sensor fusion
- > Mechanical and optical rotary encoder replacements
- > Adjustment and control knobs

ⁱ Dependent on magnet alignment and mechanical tolerances



1.3 Block Diagram

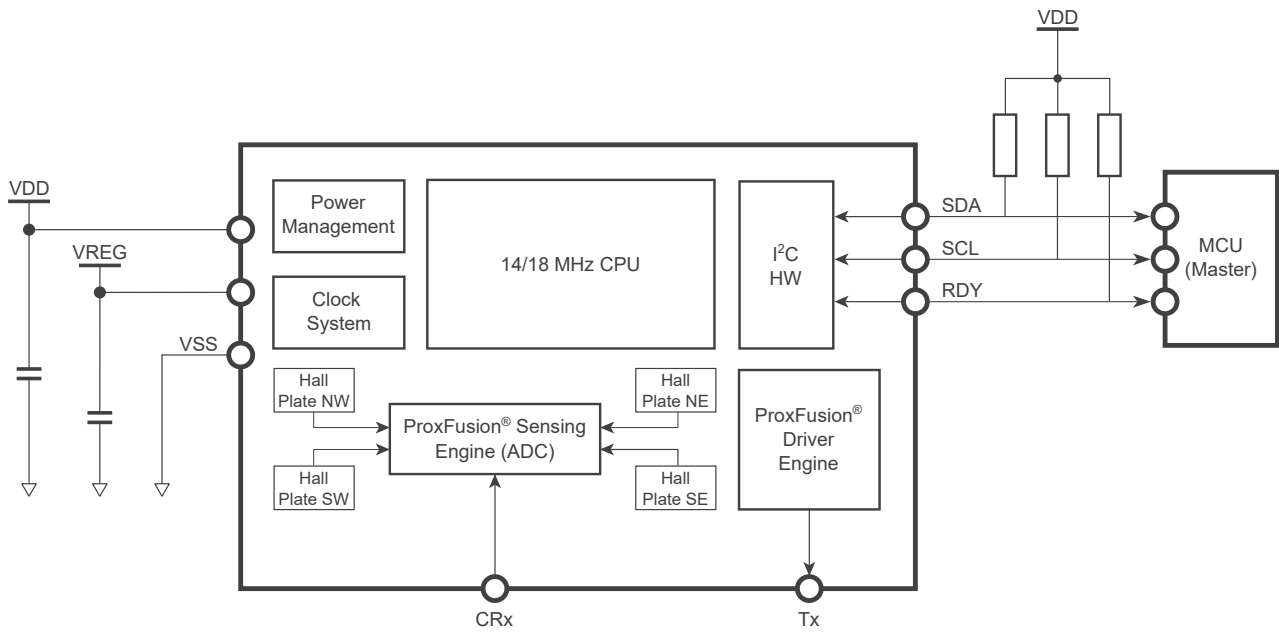

Figure 1.2: IQS324 Block Diagram



Contents

1	Device Overview	1
1.1	Main Features	1
1.2	Applications	1
1.3	Block Diagram	2
2	Hardware Connections	6
2.1	QFN20 Pinout	6
2.2	QFN20 Hall Plate Positions	7
2.3	Reference Schematic	7
2.3.1	RF Immunity	7
3	Electrical Specifications	9
3.1	Absolute Maximum Ratings	9
3.2	General Operating Conditions	9
3.3	Recommended Operating Conditions	9
3.4	ProxFusion® Electrical Characteristics	10
3.5	ESD Rating	10
3.6	Reset Levels	10
3.7	Digital I/O Characteristics	11
3.8	I ² C Characteristics	11
3.9	Current Consumption	12
3.9.1	Current Consumption With Two Active Hall Plates	12
3.9.2	Current Consumption With Four Active Hall Plates	13
4	ProxFusion® Hall Sensor Module	14
4.1	Magnet Orientation	14
4.2	Hall Rotation Measurements	15
4.3	Hall Rotation Channels	15
4.3.1	Hall Plate Selection	16
4.3.2	Hall Differentials and Phase Angle	16
4.3.3	Calculating the Phase Angle	17
4.4	Automatic Tuning Implementation (ATI)	17
4.4.1	Runtime ATI	18
4.5	Filtering	18
4.6	Interval UI	18
4.6.1	Interval Hysteresis	18
4.7	High-Accuracy Mode	19
4.8	Stationary Detection	19
4.9	Angle Offset Compensation	19
4.10	Automatic Interval Centering	20
5	Hall Normalisation	22
5.1	Normalisation Settings	22
5.2	Factory Calibration	22
5.2.1	Hall Runtime ATI	23
6	ProxFusion® Channel	24
6.1	Sensing Modes	24
6.2	Counts	24
6.2.1	Counts Linearisation	24



6.3	Button Event Detection	24
6.3.1	Long-Term Average	25
6.3.2	Direction	25
6.3.3	LTA Reseeding	26
6.4	Movement Event Detection	26
6.4.1	Long-Term Average	26
6.4.2	Movement Flags	27
6.5	Dormancy	27
6.6	Automatic Tuning Implementation	27
6.7	Automatic Re-ATI	27
6.8	Debouncing and Hysteresis	28
7	Power Options	29
7.1	Power Modes	29
7.2	AutoProx	30
7.2.1	AutoProx Limits	31
7.2.2	AutoProx Update Rate	31
8	Additional Features	32
8.1	Debug and Display Software (GUI)	32
8.2	Main Oscillator	32
8.3	Watchdog Timer (WDT)	32
8.4	Reset	32
8.4.1	Reset Indication	32
8.4.2	Software Reset	33
9	I²C Interface	34
9.1	I ² C Module Specification	34
9.2	I ² C Address	34
9.2.1	Reserved I ² C Address	34
9.3	I ³ C Compatibility	34
9.4	Memory Map Addressing	34
9.5	Memory Map Data	34
9.6	RDY/IRQ	34
9.7	Read and Write Operations	35
9.7.1	I ² C Read From Specific Address	35
9.7.2	I ² C Write To Specific Address	35
9.7.3	Modifying Bits Over I ² C	36
9.8	I ² C Timeout	36
9.9	Terminate Communication	36
9.10	Invalid Communications Return	37
9.11	Event Mode Communication	37
9.11.1	Events	37
9.11.2	Force Communication	37
10	I²C Memory Map	39
11	Ordering Information	45
11.1	Ordering Code	45
11.2	Top Marking	45
12	Package Information	46



12.1	QFN20 Package Outline	46
12.2	QFN20 Recommended Footprint	48
12.3	Tape and Reel Specifications	49
A	Memory Map Descriptions	51
A.1	System Commands (0x1000)	51
A.2	Power Settings (0x1001)	51
A.3	Event Masks (0x1002)	52
A.4	ULP and Watchdog Settings (0x1003)	52
A.5	ProxFusion Settings 0 (0x1014)	53
A.6	ProxFusion Settings 1 (0x1015)	53
A.7	Button Debounce (0x1024)	53
A.8	Movement Debounce (0x1028)	54
A.9	ProxFusion Dividers (0x1032)	54
A.10	Hall Dividers (0x103E)	54
A.11	Hall Plate Settings (0x1044)	55
A.12	Hall General Settings (0x1045)	55
A.13	Hall Init Length (0x1047)	55
A.14	Rotation UI Settings (0x1062)	56
A.15	Normalisation Mode (0x1075)	56
A.16	Power Mode Flags (0x2000)	56
A.17	Device Status (0x2001)	56
A.18	Hall Flags (0x2002)	57
A.19	Event Flags (0x2003)	57
A.20	Proxfusion States (0x2004)	58
A.21	Button Event Flags (0x2006)	58
A.22	Movement Event Flags (0x2007)	58
B	Known Issues	60
B.1	Soft Reset During Force Comms	60
B.2	Force Communication Request may Close a Communication Window	60
C	Revision History	62

2 Hardware Connections

2.1 QFN20 Pinout

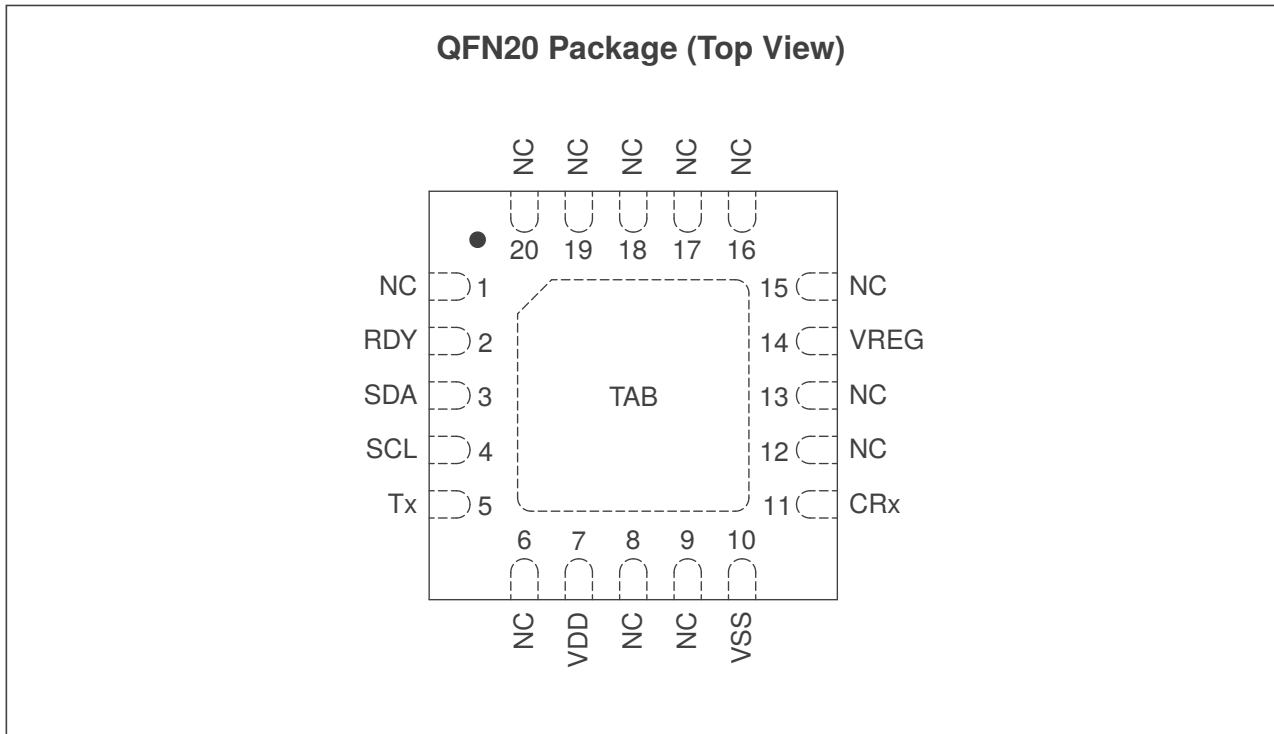

Figure 2.1: QFN20 Pinout

Table 2.1: QFN20 Pin Descriptions

Pin	Name	Type ⁱ	Function	Description
2	RDY	O	GPIO	I ² C interrupt request
3	SDA	I/O	I ² C	I ² C data
4	SCL	I/O	I ² C	I ² C clock
5	Tx	O	ProxFusion®	ProxFusion® inductive Tx pad
7	VDD	P	Power	Power supply input voltage
10	VSS	P	Power	Analog/digital ground
11	CRx	I	ProxFusion®	ProxFusion® sensing pad
14	VREG	P	Power	Internally-regulated supply voltage
*	NC	-	-	Not connected
	TAB	-	-	Thermal pad (floating). It is recommended to connect this to VSS.

ⁱ Pin Types: I = Input, O = Output, I/O = Input or Output, P = Power



2.2 QFN20 Hall Plate Positions

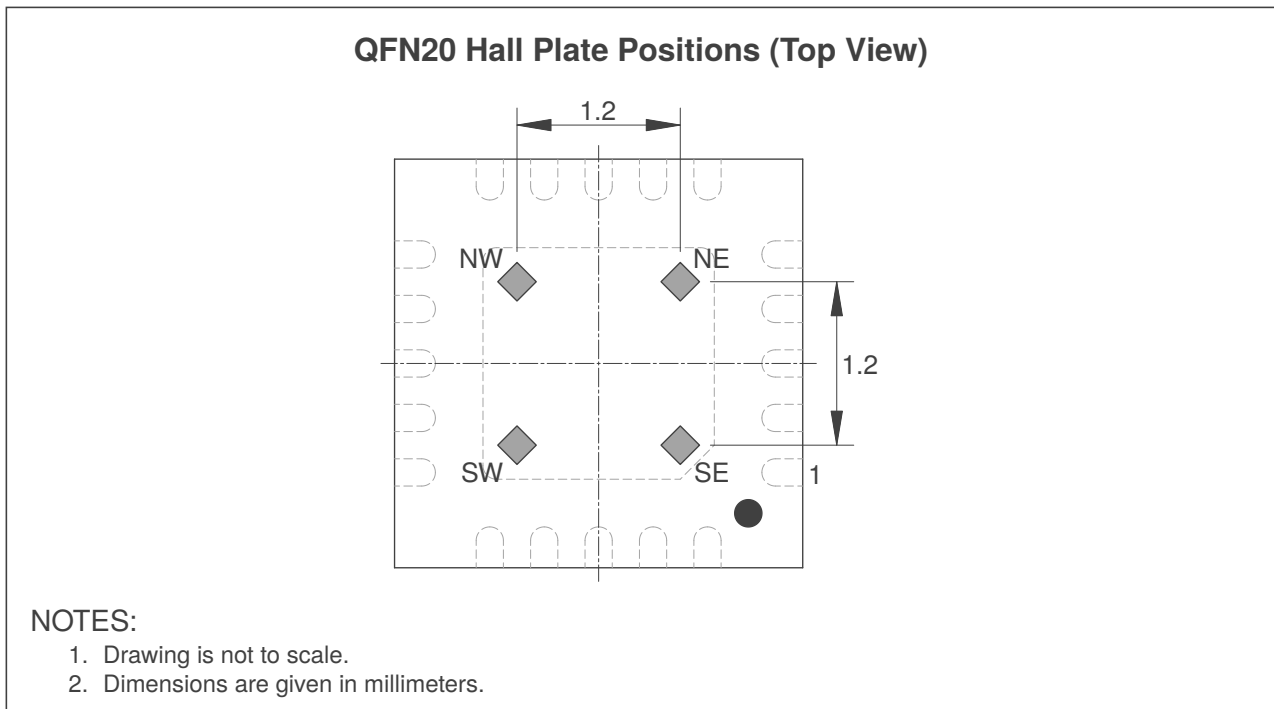

Figure 2.2: QFN20 Hall Plate Positions

2.3 Reference Schematic

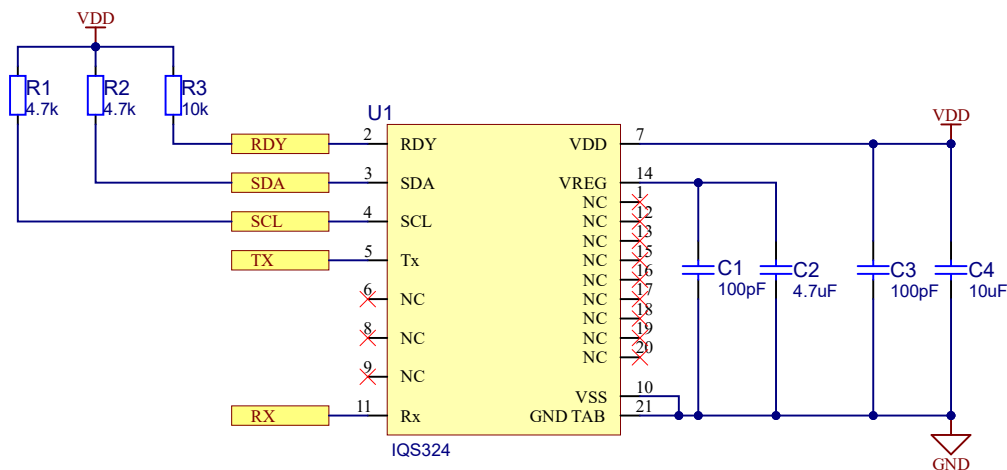

Figure 2.3: IQS324 Reference Schematic

2.3.1 RF Immunity

The IQS324 offers some immunity to high power RF noise. To improve the RF immunity, extra decoupling capacitors are suggested on VREG and VDD.

Place a 100 pF in parallel with the 4.7 μ F ceramic capacitor on VREG. Place a 10 μ F ceramic capacitor on VDD, along with an optional parallel 100 pF capacitor. All decoupling capacitors should be placed as close as possible to the VDD and VREG pads.



If needed, series resistors can be added to the Rx electrodes that are used to reduce RF coupling into the sensing pads. Normally, these are in the range of 100 Ω to 1 k Ω .

PCB ground planes also improve noise immunity.



3 Electrical Specifications

3.1 Absolute Maximum Ratings

Table 3.1: Absolute Maximum Ratings

Symbol	Rating	Min	Max	Unit
V _{DD}	Voltage applied at VDD pin (referenced to VSS)	-0.3	3.6	V
V _{IN}	Voltage applied to any ProxFusion® pin (referenced to VSS)	-0.3	V _{REG}	V
	Voltage applied to any other pin (referenced to VSS)	-0.3	V _{DD} + 0.3 (3.6 V max)	V
T _{stg}	Storage temperature	-40	85	°C

3.2 General Operating Conditions

Table 3.2: General Operating Conditions

Symbol	Parameter	Condition	Typ	Unit
f _{OSC}	Master clock frequency	f _{OSC} = 14 MHz	14	MHz
		f _{OSC} = 18 MHz	18	
f _{PROX}	ProxFusion® engine clock frequency		f _{OSC}	MHz
V _{REG}	Internally-regulated supply output	f _{OSC} = 14 MHz	1.53	V
		f _{OSC} = 18 MHz	1.8	

3.3 Recommended Operating Conditions

Table 3.3: Recommended Operating Conditions

Symbol	Parameter	Condition	Min	Rec ⁱ	Max	Unit
V _{DD}	Standard operating voltage, applied at VDD pin	f _{OSC} = 14 MHz	1.71		3.6	V
		f _{OSC} = 18 MHz	2.2			
T _A	Operating free-air temperature		-20		85	°C
C _{VDD}	Recommended capacitor at VDD		C _{VREG}	2×C _{VREG}		μF
C _{VREG}	Recommended external buffer capacitor at VREG (ESR ≤ 200 mΩ)		2.2 ⁱⁱ	4.7	10	μF

ⁱ Recommended value

ⁱⁱ Absolute minimum allowed capacitance value is 1 μF, after taking derating, temperature, and worst-case tolerance into account. Please refer to [AZD004](#) for more information regarding capacitor derating.



3.4 ProxFusion® Electrical Characteristics

Table 3.4: Recommended Operating Conditions for ProxFusion® Pins

Symbol	Parameter	Min	Max	Unit
$C_{X_{SELF-VSS}}$	Capacitance between ground and external electrodes, in self-capacitance mode	1	400 ⁱ	pF
$R_{C_{X(SELF)}}$	Series in-line resistance of self-capacitance electrodes	0	1 ⁱⁱ	kΩ

ⁱ $R_{C_{X}} = 0 \Omega$

ⁱⁱ Series resistance limit is a function of f_{xfer} and the circuit time constant, RC . $R_{max} \times C_{max} = 1/(10 \times f_{xfer})$, where C is the pin capacitance to VSS.

3.5 ESD Rating

Table 3.5: ESD Rating

			Value	Unit
$V_{(ESD)}$	Electrostatic discharge voltage	Human-body model (HBM), per ANSI/ESDA/JEDEC JS-001 ⁱ	±4000	V

ⁱ JEDEC document JEP155 states that 500 V HBM allows safe manufacturing with a standard ESD control process. Pins listed as ±4000 V may actually have higher performance.

3.6 Reset Levels

Table 3.6: Reset Levels

Parameter		Min	Max	Unit
V_{DD}	Power-up (Reset trigger) – slope > 100 V/s	1.65		V
	Power-down (Reset trigger) – slope < -100 V/s		0.9	



3.7 Digital I/O Characteristics

Table 3.7: Digital I/O Characteristics

Parameter		Test Conditions ⁱ	Min	Max	Unit
V _{OL}	Output low voltage of SDA and SCL pins	I _{OL} = 20 mA V _{DD} > 2 V		0.4	V
		I _{OL} = 20 mA V _{DD} ≤ 2 V		0.2 V _{DD}	
	Output low voltage of SDA and SCL pins in GPIO output mode	I _{OL} = 10 mA		0.1 V _{DD}	
	Output low voltage of MCLR/RDY	I _{OL} = 5 mA			
	Output low voltage of any other GPIO pin	I _{OL} = 10 mA			
V _{OH}	Output high voltage	I _{OH} = -5 mA	0.9 V _{DD}		V
V _{IL}	Input low voltage		V _{SS} - 0.3	0.3 V _{DD}	V
V _{IH}	Input high voltage		0.7 V _{DD}	V _{DD} + 0.3	V
C _b	SDA and SCL bus capacitance			550	pF

ⁱ Standard operating conditions:
V_{DD}: 1.8 V to 3.6 V, unless otherwise stated.
Operating temperature: -20 °C to 80 °C.

3.8 I²C Characteristics

Table 3.8: I²C Characteristics

Parameter		Min	Max	Unit
f _{SCL}	SCL clock frequency		1000	kHz
t _{HD,STA}	Hold time (repeated) START condition	0.26		μs
t _{LOW}	LOW period of the SCL clock	0.5		μs
t _{HIGH}	HIGH period of the SCL clock	0.26		μs
t _{SU,STA}	Set-up time for a repeated START condition	0.26		μs
t _{HD,DAT}	Data hold time	0		ns
t _{SU,DAT}	Data set-up time	50		ns
t _{SU,STO}	Set-up time for STOP condition	0.26		μs
t _{BUF}	Bus free time between a STOP and START condition	0.5		μs
t _{SP}	Pulse duration of spikes suppressed by input filter	0	50	ns

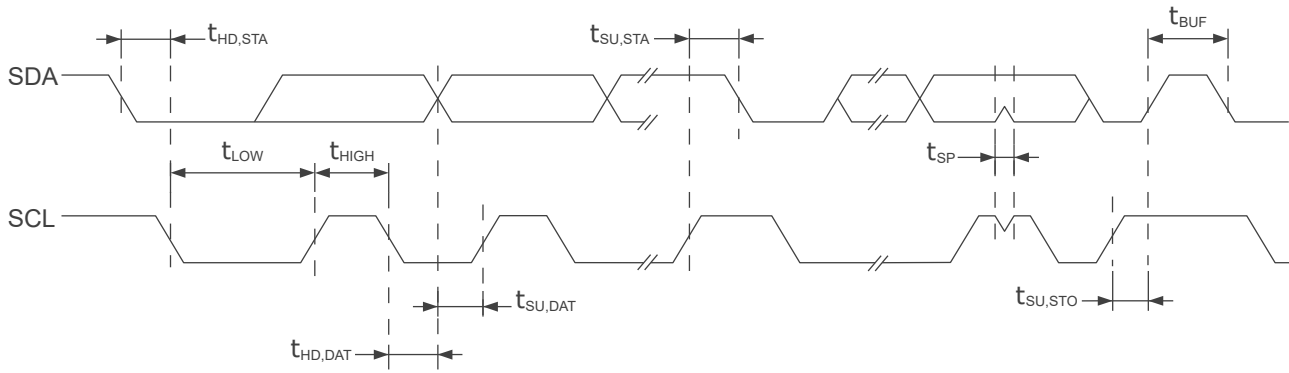

Figure 3.1: I²C Timing Diagram

3.9 Current Consumption

The current consumption of the IQS324 is highly dependent on the specific parameters configured during initialisation, as well as on the frequency and duration of I²C communications. Therefore, the following tables serve as an illustration of the expected power consumption for similar configurationsⁱ. All measurements are taken with *Event Mode* enabled, without any sensor activations, and without any I²C communications. All other settings, unless stated otherwise, are kept default.

Current consumption values are provided for both 14 MHz and 18 MHz f_{OSC} configurations. For more information, please refer to Section 8.2.

3.9.1 Current Consumption With Two Active Hall Plates

The following tables show the expected current consumption of the IQS324 in a diagonal off-axis configuration, where only two opposing corner Hall plates are sampled, as shown in Section 4.3.1.

Table 3.9: IQS324 Typical Current Consumption at 14 MHz f_{OSC}

Power Mode	Report Rate [ms]	Current Consumption [µA]		
		Hall & Touch	Hall	Touch
High Accuracy	4	490	420	230
Normal Power	20	113	110	63
Low Power	100	24	24	14
Ultra Low Power	500	6	5.5	3.6
Auto Prox		N/A	2.1	1.5

ⁱ These measurements are based on bench testing and have not been characterised over large volumes.



Table 3.10: IQS324 Typical Current Consumption at 18 MHz f_{osc}

Power Mode	Report Rate [ms]	Current Consumption [μ A]		
		Hall & Touch	Hall	Touch
High Accuracy	4	480	470	290
Normal Power	20	124	114	67
Low Power	100	26	24	15
Ultra Low Power	500	7	6	4
Auto Prox		N/A	2.3	1.5

3.9.2 Current Consumption With Four Active Hall Plates

The following tables show the expected current consumption of the IQS324 in a configuration that samples all four Hall plates. This applies to a “North-South” or “East-West” off-axis configuration.

Table 3.11: IQS324 Typical Current Consumption at 14 MHz f_{osc}

Power Mode	Report Rate [ms]	Current Consumption [μ A]		
		Hall & Touch	Hall	Touch
High Accuracy	4	560	460	230
Normal Power	20	128	121	63
Low Power	100	27	27	14
Ultra Low Power	500	7	5.5	3.6
Auto Prox		N/A	2.2	1.5

Table 3.12: IQS324 Typical Current Consumption at 18 MHz f_{osc}

Power Mode	Report Rate [ms]	Current Consumption [μ A]		
		Hall & Touch	Hall	Touch
High Accuracy	4	650	500	280
Normal Power	20	142	124	67
Low Power	100	30	27	15
Ultra Low Power	500	8	6.2	4
Auto Prox		N/A	2.3	1.5



4 ProxFusion® Hall Sensor Module

The IQS324 contains four equally-spaced Hall plates that measure the magnetic field strength and orientation of a nearby diametrically polarised magnet. These Hall plates are used to calculate the relative angle of an off-axis magnet with regards to the IC. The angle can be divided into discrete intervals using the Interval UI, providing a convenient interface for scroll wheel applications.

4.1 Magnet Orientation

The IQS324 is designed to be used in an off-axis orientation with regard to the magnet. Figure 4.1 shows the recommended configuration for an off-axis Hall-rotation sensor. Here, the magnet is oriented diagonally relative to the IC, and two diagonal plates are used for the rotation sensing. This is generally recommended if off-axis is required, as it provides the largest phase angle.

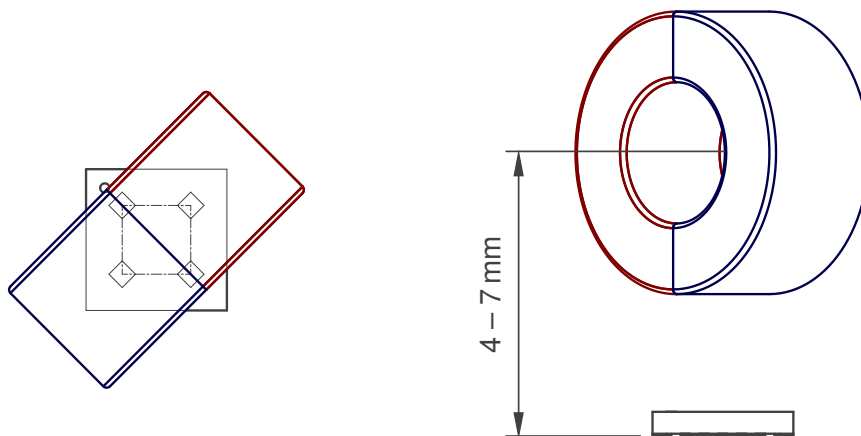

Figure 4.1: Recommended Magnet Orientation for an Off-Axis Angle Measurement Application

Figure 4.2 shows an alternate off-axis configuration that uses two plates per side to measure the Hall rotation. This configuration results in a smaller phase angle than when using the diagonal plates, and is thus only recommended for shorter distances between the magnet and IC.

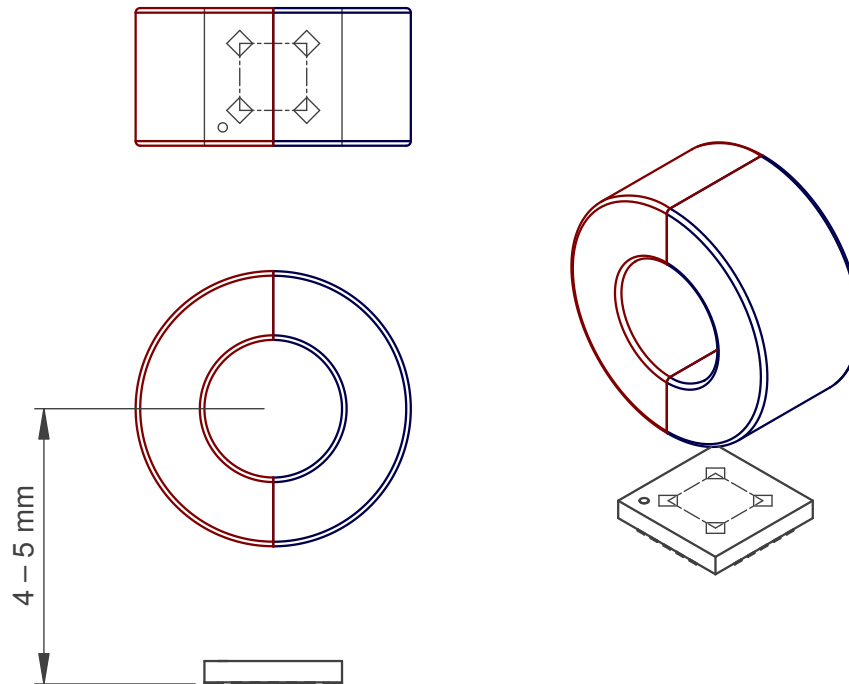

Figure 4.2: Alternate Magnet Orientation for Off-Axis Angle Measurement Applications

Please refer to Section 4.3.1 for settings related to off-axis configuration selections. Also refer to [AZD127](#) for more information regarding off-axis design guidelines.

4.2 Hall Rotation Measurements

The IQS324 provides the angle measurement in three different values:

- > **Absolute Angle:** Raw angle measurement, provided as an unsigned 16-bit value, where the range [0, 65536) maps to [0°, 360°). This represents the angle of the magnet relative to the IC.
- > **Processed Angle:** Angle measurement after post-processing, also an unsigned 16-bit value. This output is filtered and includes an angular offset. This output can be used for applications requiring high-resolution measurements.
- > **Interval:** The output of the interval UI, which divides the unsigned 16-bit processed angle into several sections, or intervals. This output is recommended for applications with mechanical ratchets and is supplemented by the hysteresis and auto-zero features.

4.3 Hall Rotation Channels

The Hall-effect rotation measurement on the IQS324 relies on two measurements on each of the four Hall plates, where the second measurement is inverted to the first. These two measurements allow for the calculation of a reference value and a differential value, from which the relative strength of the magnetic field can be inferred. The reference value is calculated as the average of the two measurements, and the differential value is calculated as the difference between the measurements.

As a result, the IQS324 performs up to eight Hall-effect measurements, four of which are inverted to the others. These measurement values (channels) are available in the [Hall Plate Counts](#) and [Hall Reference](#) registers.



4.3.1 Hall Plate Selection

By default, the IQS324 uses opposing diagonal plates to measure off-axis magnet rotation. Either pair can be selected by modifying the *Magnet Orientation* setting in the *Hall General Settings* register. The “diagonal axis” refers to the axis of rotation of the magnet. “NW to SE Axis” will use the NE and SW plates, and vice versa.

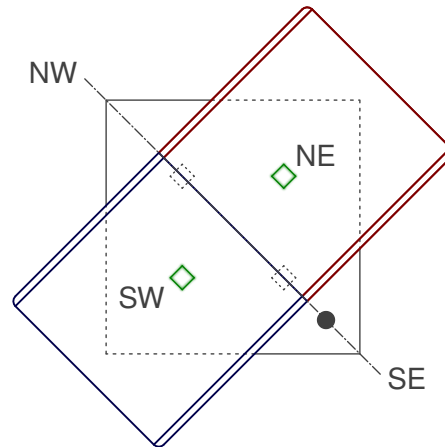

Figure 4.3: NW-SE Off-Axis Plate Selection

Alternatively, the “North-South (N-S)” or “West-East (W-E)” axes can be specified, which will use two pairs of plates to measure the off-axis rotation. “N-S” axis selection will use the East and West plates, and vice versa.

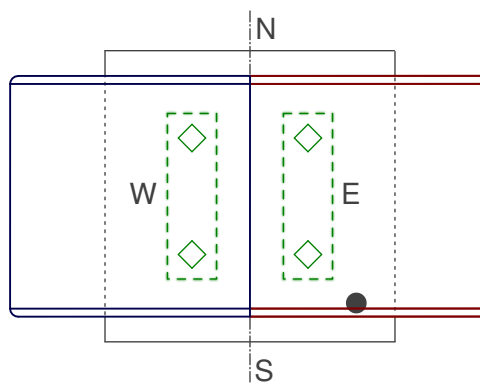

Figure 4.4: N-S Off-Axis Plate Selection

4.3.2 Hall Differentials and Phase Angle

For off-axis configurations, the Hall counts are combined into two *Hall Differential* signals, which are used to calculate the magnet’s angle. The phase angle between these two signals, illustrated in Figure 4.5, are dependent on the geometry of the application. This phase angle must be calibrated, and set in the *Phase Angle* registers. With a measured phase angle, θ , the register values must be set to:

$$\text{Phase Angle Sin} = 65536 \times \sin(\theta)$$

$$\text{Phase Angle Cos} = 65536 \times \cos(\theta)$$

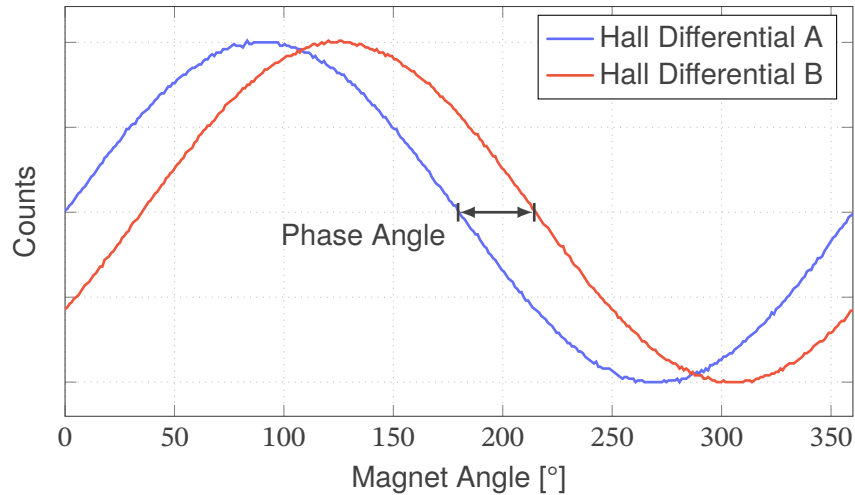

Figure 4.5: Hall Differential Signals

Off-axis applications typically have a smaller phase angle, in the range of 20° to 40°.

4.3.3 Calculating the Phase Angle

To calculate the phase angle of an off-axis magnet setup, the two Hall Differential signals must be recorded over at least one full rotation of the magnet. These signals then need to be normalised with:

$$A_{norm} = \frac{\frac{\max(A)-A}{A}}{\frac{\max(A)-\min(A)}{\min(A)}} \quad B_{norm} = \frac{\frac{\max(B)-B}{B}}{\frac{\max(B)-\min(B)}{\min(B)}}$$

The data will now range between 0 and 1.

Sample both signals where $A_{norm} \approx 0.5$. With these values, the phase angle, θ , can be calculated as:

$$\theta = \sin^{-1}(|B_{norm} - A_{norm}| \cdot 2) \quad (\text{where } A_{norm} \approx 0.5)$$

4.4 Automatic Tuning Implementation (ATI)

ATI is an automatic sensor calibration algorithm that configures the *Hall Plate Offsets* to ensure accurate Hall-effect sensing for a range of different magnet sizes and strengths. The ATI aims to modify the Hall plate settings such that the Hall channel reference values are within the range defined by the *Target* and *ATI Band* parameters. Recommended value for the target is between 8000 and 14000.

The overall gain of the Hall sensing circuitry is controlled by three parameters:

- > *Hall Amplifier Gain*
- > *Hall Dividers*
- > *Hall Offsets*

The first two parameters, Hall Amplifier Gain and Hall Dividers, must be chosen at design time. This can be done with the aid of the IQS324 GUI. Typically, these can be chosen such that the Hall channels swing around ± 2000 to ± 4000 counts from the reference over a full rotation of the magnet.



Once the gain parameters are chosen, they can be fixed for all modules across production. The ATI feature then uses the Hall Offset values to compensate automatically for any variation across production.

When tuning the Hall gain parameters, the Hall Amplifier Gain value (in the *Hall Plate Settings* register) can generally be set to a starting value of '1' (x2). Then, the Hall Dividers can be increased or decreased until the desired counts swing (± 2000 to ± 4000 counts) is achieved. Recommended Hall Divider values are given in Table A.2. It is generally recommended to keep the Hall Divider gain ratio lower than 1. If this provides insufficient gain, the Hall Amplifier Gain value should be increased as necessary.

4.4.1 Runtime ATI

ATI is performed automatically at start-up, as well as when all the following criteria are met:

- > The stationary flag is set; see Section 4.8.
- > The *Hall Reference* of a channel is outside the threshold defined by Equation (1).

$$|\text{Hall Target} - \text{Hall Reference}| > \text{Hall ATI Band} \quad (1)$$

- > Runtime ATI is enabled in *Hall UI Settings*.

4.5 Filtering

The IQS324 includes a dynamic angle filter that increases its bandwidth based on the magnet's current speed. This allows the filter to remove most high-frequency noise while the magnet is stationary, and prevents the filter from aliasing during high-speed rotations. The overall strength of the filter can be adjusted with the *Angle Filter Beta* value.

In Low and Ultra Low power modes, the *Low Power Beta* is used instead. This should be set to a *larger* value than the normal beta value, to reduce measured jitter at lower report rates.

4.6 Interval UI

The interval UI divides the 16-bit Processed Angle into a value between 0 and the *Number of Intervals*, where the size of each interval is defined as:

$$\text{Interval Size} = \frac{2^{16}}{\text{Number of Intervals}} \quad (2)$$

This is especially useful for applications that do not require a high measurement resolution or that use mechanical ratchets.

4.6.1 Interval Hysteresis

The Interval Hysteresis prevents the interval output from jittering between two intervals, causing unnecessary interval change events. The behaviour of the hysteresis is shown in Figure 4.6.

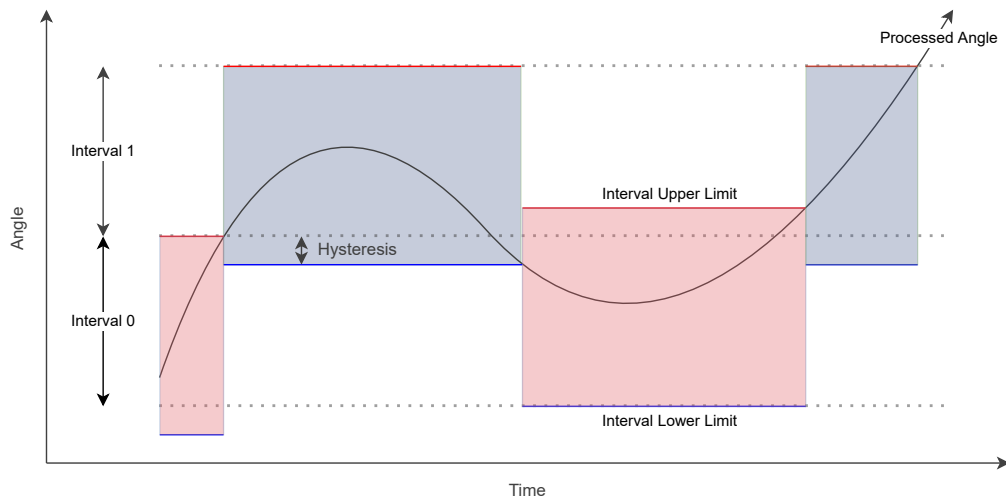

Figure 4.6: Illustration of the Interval Size and Interval Hysteresis

The amount of hysteresis applied can be modified by changing the *Interval Hysteresis* value. Hysteresis is a 16-bit value, in the same unit as the Processed Angle. Hysteresis should therefore be chosen based on the interval size calculated in the previous section, and on the amplitude of the noise on the Processed Angle.

4.7 High-Accuracy Mode

The High-Accuracy mode of the IQS324 will increase the report rate of the device to sample Hall rotation measurements more accurately and to reduce aliasing during high rotation rates. The IQS324 will enter High-Accuracy mode in the event of an interval change.

The *High-Accuracy* flag will remain set for the duration of the *High-Accuracy Timeout*. This flag is used to identify whether to transition into the High-Accuracy power mode and can be configured to signal an automatic interval centering event when High-Accuracy mode is exited.

4.8 Stationary Detection

The IQS324 will set a *Stationary* flag if no movement is detected during the period defined by the *Stationary Timeout* value. This Stationary flag is used to identify whether to go into a lower power mode. Runtime ATI for the Hall channels is also only executed when stationary.

4.9 Angle Offset Compensation

Angle offset compensation is applied to ensure the output angle corresponds to the angle of the wheel, rather than the raw angle of the magnet, as shown in Figure 4.7. This is especially important for ratchet applications, where the intervals generated by the IC must match the mechanically-defined intervals of the wheel.

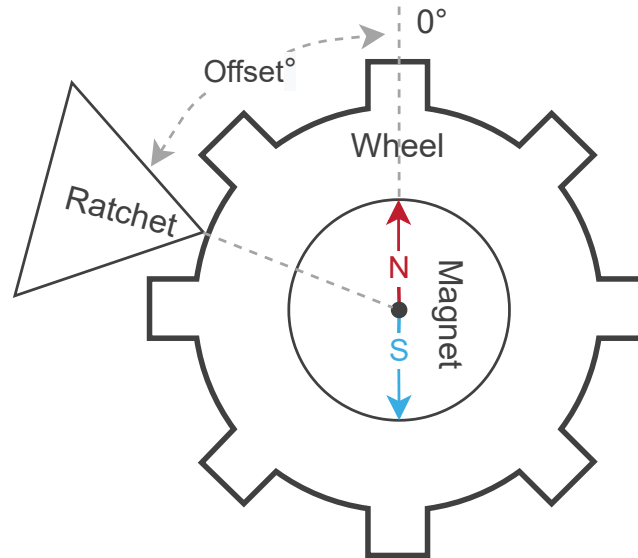

Figure 4.7: Illustration of the Absolute Angle Offset

The angle offset is updated when the *Zero* command in the [System Commands](#) register is set. This sets the Processed Angle to the centre of interval 0, and thus adjusts the angle offset accordingly. The *Zero* command is also set automatically on start-up.

The angle offset is also modified by the automatic interval centering functionality, to align the intervals with a mechanical ratchet automatically.

Finally, the angle offset can be manually changed via the [Angle Offset](#) register.

4.10 Automatic Interval Centering

The interval centering functionality (or “auto-zero”) of the IQS324 allows the device to modify the absolute angle offset of the Processed Angle such that the Processed Angle is at the centre of the current interval. This dynamically adjusts the absolute angle offset until the Processed Angle aligns with the physical intervals of a ratchet device.

The auto-zero functionality can be set to one of five different modes in the [Hall UI Settings](#):

- > **Off:** The device will never allow an automatic interval zero action to happen, and the master device will have to send an instruction over I²C to set the *Zero* bit.
- > **Stationary:** An auto-zero event will occur when the High-Accuracy timeout event occurs. A single adjustment is made to the absolute angle offset each time the device exits High-Accuracy mode. The [Auto-Zero Beta](#) parameter defines the size of the adjustment, with an auto-zero beta value of 0 resulting in a jump to the exact centre of the interval. This behaviour can be seen in Figure 4.8.
- > **Continuous:** The auto-zero filter will cause the Processed Angle to move continuously towards the centre of the current interval. It is recommended to use an auto-zero beta value of 10 or higher to allow the Processed Angle to move between intervals during slower rotations. This mode is recommended for devices without a mechanical ratchet. This behaviour can be viewed in Figure 4.9.
- > **Release:** An auto-zero event will occur on a Movement Exit event on the ProxFusion channel. If the ProxFusion channel is configured as a capacitive touch channel, this exit event could indicate that the user released the device.



- > **Continuous-Release:** Performs auto-zero using Continuous mode, but only while the ProxFusion Button event is not in activation. This automatically adjusts the angle offset as long as the user is not interacting or touching the device.

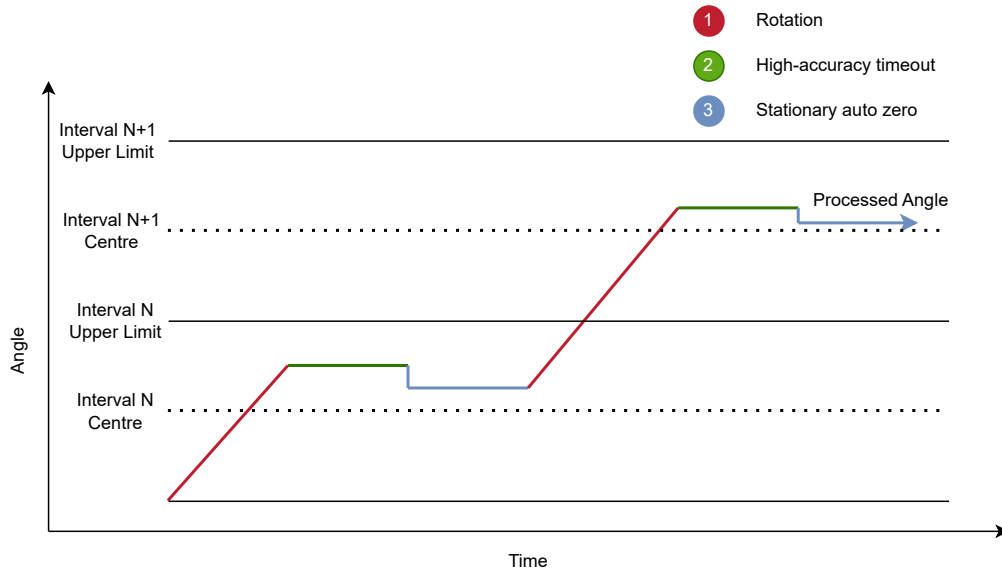

Figure 4.8: Stationary Auto-zero Behaviour

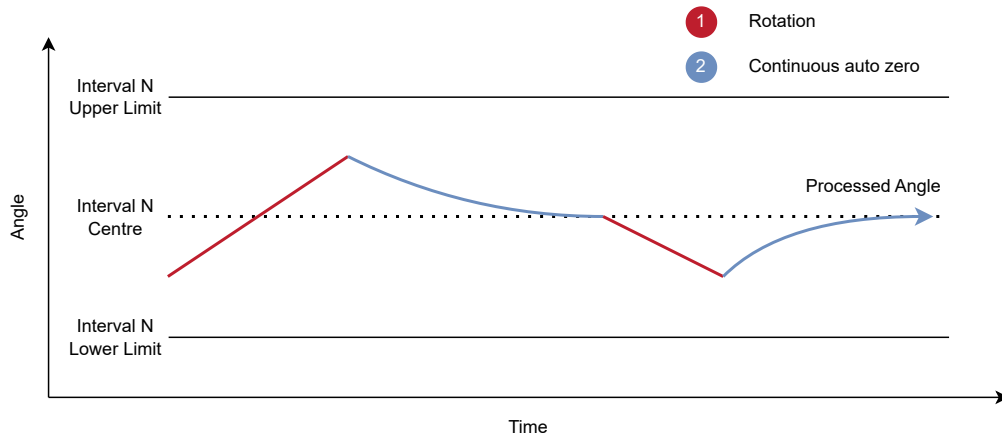

Figure 4.9: Continuous Auto-zero Behaviour



5 Hall Normalisation

Off-axis magnet orientations require extremely tight mechanical tolerances to ensure accurate Hall-rotation measurements. Magnet misalignments and wobble can result in differences in amplitudes of the measured magnetic field strengths across different Hall plates. To compensate for this, the IQS324 attempts to normalise the *Hall Differential* signals by tracking the minimum and maximum values of the Hall Differentials during runtime. These minimum and maximum values are then used to correct for differences in amplitude and DC offsets between the A and B Hall Differentials. Normalisation attempts to set the amplitude of the Differentials to approximately 16384 counts.

Min/max tracking is performed over the course of each full rotation, and the minimum and maximum values are stored in the *Normalisation Minimum/Maximum* registers. The resulting normalised Hall Differential signals are then stored in the *Normalised Hall Field* registers.

5.1 Normalisation Settings

Hall normalisation can be set to 'Off', 'Manual', or 'Auto'.

- > **Off:** Normalisation is disabled.
- > **Manual:** The Hall Differential signals are normalised based on the values stored in the Normalisation Min/Max registers. However, these normalisation values are static. The IQS324 does not perform any tracking of minimum and maximum Differentials.
- > **Auto:** The IQS324 performs min/max tracking with each rotation, continuously updating these values to track and compensate for any changes that may be introduced due to environmental drift. The stored minimum and maximum values are filtered based on the *Normalisation Beta* value after each rotation. This is the default, and recommended, setting for off-axis configurations.

5.2 Factory Calibration

In 'Auto' normalisation mode, normalisation is only applied once valid (non-zero) minimum and maximum values have been measured. However, after start-up, these values are only seeded after completing a few full rotations. As a result, the first rotation after start-up may have lower accuracy than expected. In order to improve the accuracy of the Hall-rotation sensing from power-on, initial minimum and maximum normalisation values can be written to the IQS324. This requires a factory calibration procedure to measure, read, and store the nominal normalisation parameters. On all subsequent starts, these values can then be written to the IQS324.

The following factory calibration procedure is recommended:

- > Initialise the IQS324 over I²C as normal, with the desired settings.
- > Perform an ATI by setting the *Hall ATI* bit in the *System Commands* register. This resets the minimum and maximum values to 0.
- > Wait for ATI to complete by waiting for the next communications (RDY) window.
- > Rotate the magnet by at least 540° (1.5 revolutions).
- > Read and store the values of the *Normalisation Minimum/Maximum* registers.

This calibration sequence only needs to be done once, during production. Once these compensation values are known, they can be written to the IQS324 every time on start-up.

The following procedure is then recommended for normal operation:

- > Initialise the IQS324 over I²C as normal, with the desired settings.



- > Perform an ATI by setting the *Hall ATI* bit in the *System Commands* register.
- > Wait for ATI to complete by waiting for the next communications (RDY) window.
- > Disable the I²C read-only protection by setting the *Disable Read-Only Check* bit in the *ULP and Watchdog Settings* register to '1'.
- > Write the stored min/max values to the *Normalisation Minimum/Maximum* registers of the IQS324.
- > Re-enable the I²C read-only protection.

5.2.1 Hall Runtime ATI

Note that on the IQS324, the Normalisation minimum and maximum values are reset to 0 after any Hall ATI event. This means that these values may be unintentionally cleared during normal operation, during a runtime ATI.

This can be addressed in two ways:

1. Disable Hall Runtime ATI. This will prevent the IQS324 from doing ATI boundary checks. This may make the device more sensitive to environmental changes; however the Hall-rotation sensing is typically robust against these changes.
2. Monitor the *ATI Event* flag in the *Event Flags* register, and re-write the Normalisation min/max values to the device if an ATI event occurs.



6 ProxFusion® Channel

The IQS324 features a ProxFusion® sensing channel that uses Azoteq’s patented on-chip ProxFusion® module to measure and process relative changes in capacitive and inductive sensors.

The channel provides two primary Event types – *Button* and *Movement* events. The Button event attempts to track slow changes and long term activations, whereas the Movement event detects smaller, fast changes. Each of these events store their own reference and delta values.

6.1 Sensing Modes

The ProxFusion® channel supports the following sensing modes:

- > Self-capacitive sensing
- > Resonated inductive sensing

The sensing mode can be modified in the *ProxFusion Settings 1* registers.

Please refer to the following [application notes](#) for more information:

- > AZD004: Overview of Azoteq’s ProxFusion® Sensing
- > AZD115: Design Guidelines for Inductive Sensing
- > AZD125: Design Guidelines for Capacitive Touch Sensing

6.2 Counts

The ProxFusion® module reports a capacitance or inductance measurement as a relative, unit-less value referred to as “Raw Counts”. These raw counts are related to the number of charge transfer cycles necessary to charge an internal sampling capacitor, and are typically inversely proportional to the signal measured on the external sensor.

6.2.1 Counts Linearisation

The IQS324 does not directly use the “Raw Counts” obtained from the sensing module, but uses “Linearised Counts”, which is calculated as

$$\text{Linearised Counts} = \frac{3276750}{\text{Raw Counts}} \quad (3)$$

All references to “Counts” in this datasheet, and in the I²C memory map, use these Linearised Counts values.

After linearisation, counts are filtered using a low-pass IIR filter to reduce the high-frequency noise in the measurement. The response of the filter can be adjusted with the *Counts Filter Beta* value in the *Filter Betas* registers. Higher beta values result in a slower filter response, with less noise on the channel.

6.3 Button Event Detection

The Button Event attempts to emulate the behaviour of a typical button, which stays in activation for as long as it is pressed.



6.3.1 Long-Term Average

Button events are detected by comparing the filtered counts value to a reference value, known as the Long-Term Average (LTA). While the channel is not in activation, the LTA is slowly updated to track changes in the environment using a low-pass filter.

The difference between the filtered counts and the LTA is stored as the *Delta* value.

$$\text{Delta} = \text{LTA} - \text{Counts} \quad (4)$$

The delta is used to detect user interaction by comparing it to the *Button Threshold*. The channel enters the active state when the delta exceeds the threshold, and the *Button Active* bit in the *Button Events* register will be set.

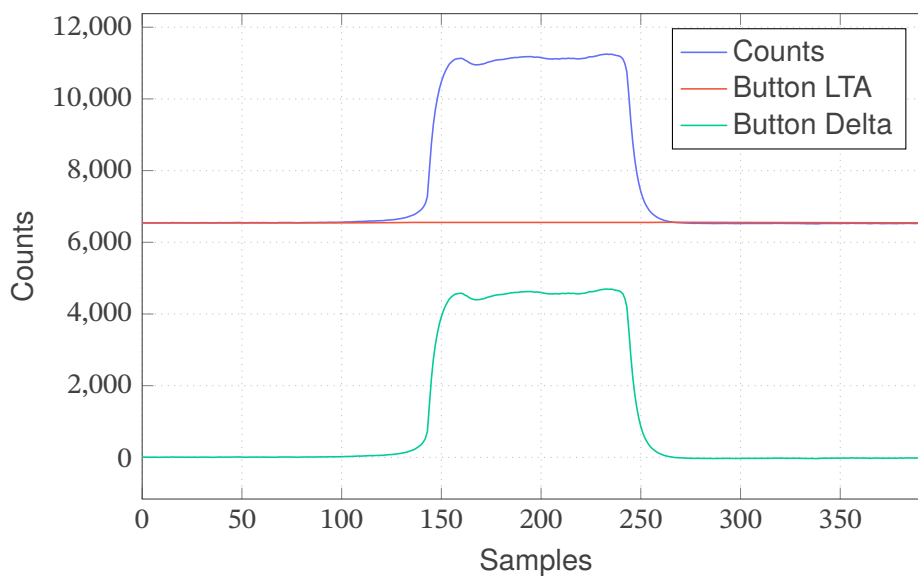

Figure 6.1: Button UI Activation

The LTA is then halted (kept constant) while the Button event is active, or while the delta exceeds the *LTA Halt Threshold*, as shown in Figure 6.1. The LTA Halt Threshold can typically be made smaller than the Button Threshold. This may help increase the sensitivity of the event detection during slower activations, preventing the LTA from drifting during user interaction.

The response of the LTA filter is controlled by the various *LTA Beta* values. The *LTA Beta* value sets the response of the filter during High-Accuracy and Normal power modes, whereas the *Low Power LTA Beta* is used during Low and Ultra-Low power modes. The Low Power Beta value should be set to a *larger* value than the Normal Beta value, to maintain adequate sensitivity at lower sampling rates.

6.3.2 Direction

Negative delta values are typically ignored, as they typically indicate an unexpected decrease in signal. If a negative delta value exceeds the *Fast LTA Bound* threshold, the LTA will be updated using the *Fast LTA Beta* filter. This behaviour can be disabled by setting the *Bi-Directional* bit, or the sign of the delta can be inverted by setting the *Inverse* bit in the *ProxFusion Settings 0* register.



6.3.3 LTA Reseeding

The reseed function of the device will replace the filtered counts and the long-term average value of the channel with the latest sampled counts value to reset the environmental reference of the channel. This may be necessary in certain instances when the Button event gets incorrectly stuck in an activation. Detection of stuck states is controlled by the *Button Timeout* parameter. If the Button event remains active for this timeout duration, the LTA is reseeded automatically. This behaviour can be disabled by setting the timeout parameter to 0.

A *Reseed* command can also be given manually by setting the corresponding bit in *System Commands*.

6.4 Movement Event Detection

The Movement Event detects small, rapid changes or movements on the ProxFusion channel. This may be used as a simple wake-up event, triggered as the user approaches the sensor.

6.4.1 Long-Term Average

The Movement event tracks its own LTA and delta values, separately from the Button event. In contrast to the Button event, the Movement event does not halt its LTA. Instead, it filters using the regular LTA Beta value while not in activation, and filters with the Fast LTA Beta while the event is active (while the delta is larger than the *Movement Threshold*).

The purpose of this is to track increases in the rate of change of counts. This typically occurs as a user is approaching or releasing a proximity sensor. Outside of activations, the LTA is updated slowly to maximise sensitivity to changes in counts. As soon as the delta exceeds the threshold, the fast LTA is used to exit the movement event as quickly as possible, to be ready to detect the next change in counts. An example of the Movement's response to a quick tap is shown in Figure 6.2.

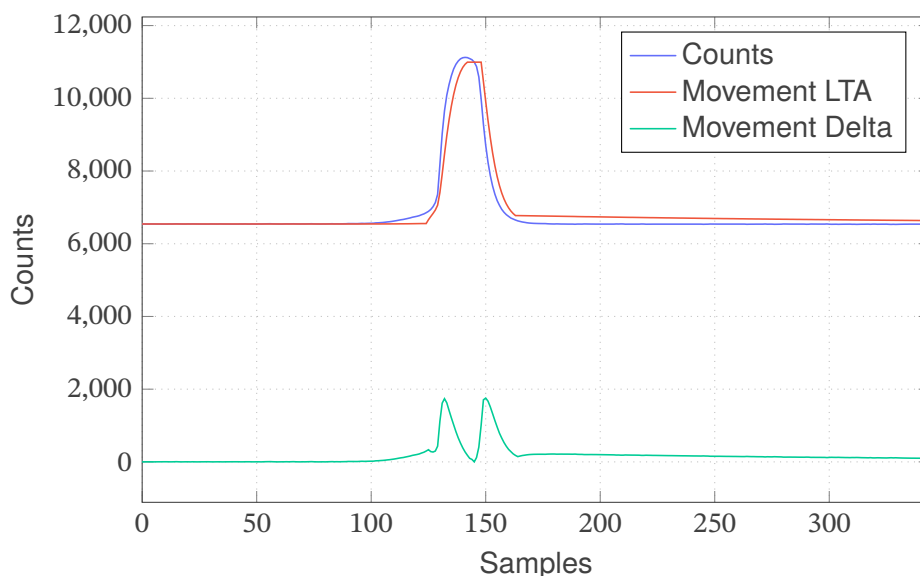

Figure 6.2: Movement UI Activation



6.4.2 Movement Flags

The primary outputs of the Movement Event are the *Movement Entered* and *Movement Exited* flags in the *Movement Event Flags* registers. The Movement Entered flag is set while the delta exceeds the threshold with a positive sign, and indicates that a user approached the sensor, or entered touch. The Movement Exited flag is set while the delta exceeds the threshold with a negative sign, indicating that the user released the sensor. These flags can be flipped by setting the *Inverse* bit.

Note that the Movement event is not affected by the *Bi-Directional* setting.

During slower movements, the same flag may be set multiple times consecutively. For example, an Enter event may occur repeatedly as the user approaches the sensor.

6.5 Dormancy

The touch dormancy flag will be set if the dormancy timeout event occurs after no touch input is received for the period defined in the *Dormancy Timeout* parameter. The IQS324 may only enter lower power states once the dormancy flag is set.

Note that the dormancy timer also acts as a timeout for the LTA Halt flag, if the channel's delta exceeds the LTA Halt Threshold while not in any active state. When dormancy is set, the LTA is reseeded, and will then continue to track environmental changes normally.

6.6 Automatic Tuning Implementation

The ATI is a sophisticated technology implemented in ProxFusion® devices to allow optimal performance of the devices for a wide range of sensing electrode designs, without modification to external components.

The ATI functions by using the *Base* and *Target* parameters to calculate appropriate *Divider* and *Compensation* values to achieve an LTA approximately equal to the ATI target value. Note that the base and target values are specified in terms of Linearised Counts, and the base value should always be larger than the target. Typically, a base value of 10000 to 30000 can be used, while a target value between 3500 and 10000 is recommended.

If the ATI algorithm cannot achieve a counts value within the ATI Band, the IQS324 will set the channel's ATI Error flag.

The Coarse Gain parameter in the *ProxFusion Dividers* register can be tuned in the GUI. The ATI will then adjust the Fine Divider parameter until the counts reach the base value. The Coarse Gain should be manually adjusted at design time until the Fine Divider reaches a value between '4' and '14' after ATI. It can then be fixed across production.

6.7 Automatic Re-ATI

One of the most important features of the automatic Re-ATI functionality of the IQS324 is that it allows easy and fast recovery from an incorrect ATI, such as when performing ATI during user interaction with the sensor. It is always recommended to have the automatic Re-ATI functionality enabled. When a Re-ATI is performed on the IQS324, the *ATI Event* status bit will be set momentarily to indicate that this has occurred.

An automatic Re-ATI operation is performed when the reference of a channel drifts outside the acceptable range around the ATI Target, which is defined by the *ATI Band* parameter. Automatic Re-ATI is also triggered on ATI Error states.



6.8 Debouncing and Hysteresis

Each of the Button and Movement events provides two mechanisms to prevent jitter: debouncing and hysteresis.

Debouncing occurs when the Button or Movement delta initially crosses the threshold. It forces the IQS324 to perform a number of quick measurements (at High-Accuracy report rate), checking that all measurements exceed the threshold. The event's *Debouncing* flag is set as long as debouncing is active. Once debouncing is complete, the event's *Active* flag is set.

The number of high-frequency measurements to execute can be configured independently for entering or exiting the event's active state in the *Debounce* register. Setting the debounce values to '0' or '1' will disable debouncing.

Hysteresis allows the channel to use different enter and exit thresholds for an event. Once the event has entered the active state by exceeding the normal threshold value, the exit threshold is calculated as

$$\text{Exit Threshold} = \text{Threshold} \times \left(1 - \frac{\text{Hysteresis Value}}{256}\right) \quad (5)$$

For example, with a Button threshold of 100 counts, and a hysteresis value of 50, the Button event will enter the Active state when the delta exceeds 100 counts, and will exit the Active state when the delta drops down to $100 \times (1 - 50/256) = 80$ counts.



7 Power Options

7.1 Power Modes

The IQS324 offers 5 power modes:

> High-Accuracy (HA)

- Highest current consumption
- High-accuracy mode is always entered during debouncing on the ProxFusion channel.
- When in automatic power mode, high-accuracy mode is entered when:
 - * The *Interval* value has changed.

> Normal Power Mode (NP)

- The default operating power mode
- When in automatic power mode, normal power mode is entered when:
 - * Exiting high-accuracy mode after the high-accuracy timeout.
 - * Touch or movement event on the ProxFusion channel.

> Low Power Mode (LP)

- Typically configured with a slower report rate to reduce current consumption.
- When in automatic power mode, low power mode is entered when the two following conditions are met:
 - * Hall *Stationary* flag is set.
 - * ProxFusion *Dormant* flag is set.

> Ultra-Low Power Mode (ULP)

- Recommended being configured for the slowest report rate.
- In automatic power mode, the device will enter ULP mode after the *ULP Timeout* Event occurs. The ULP timer is started when the device enters LP mode.
- By default, ULP mode still samples both the Hall plates and the ProxFusion channel every cycle. ULP mode can instead be configured to use AutoProx, which only samples a single channel each cycle to further reduce current consumption.

> Halt Mode

- Is entered and exited by an I²C command.
- Places device in standby mode.
- No analog sampling events occur during halt mode.
- Entering halt mode safely requires the manual configuration of a *Watchdog Period* of 4000 ms.
- To exit halt mode the master device must open a forced communications window (Refer to Section 9.11.2) and select an alternative power mode for the IQS324.

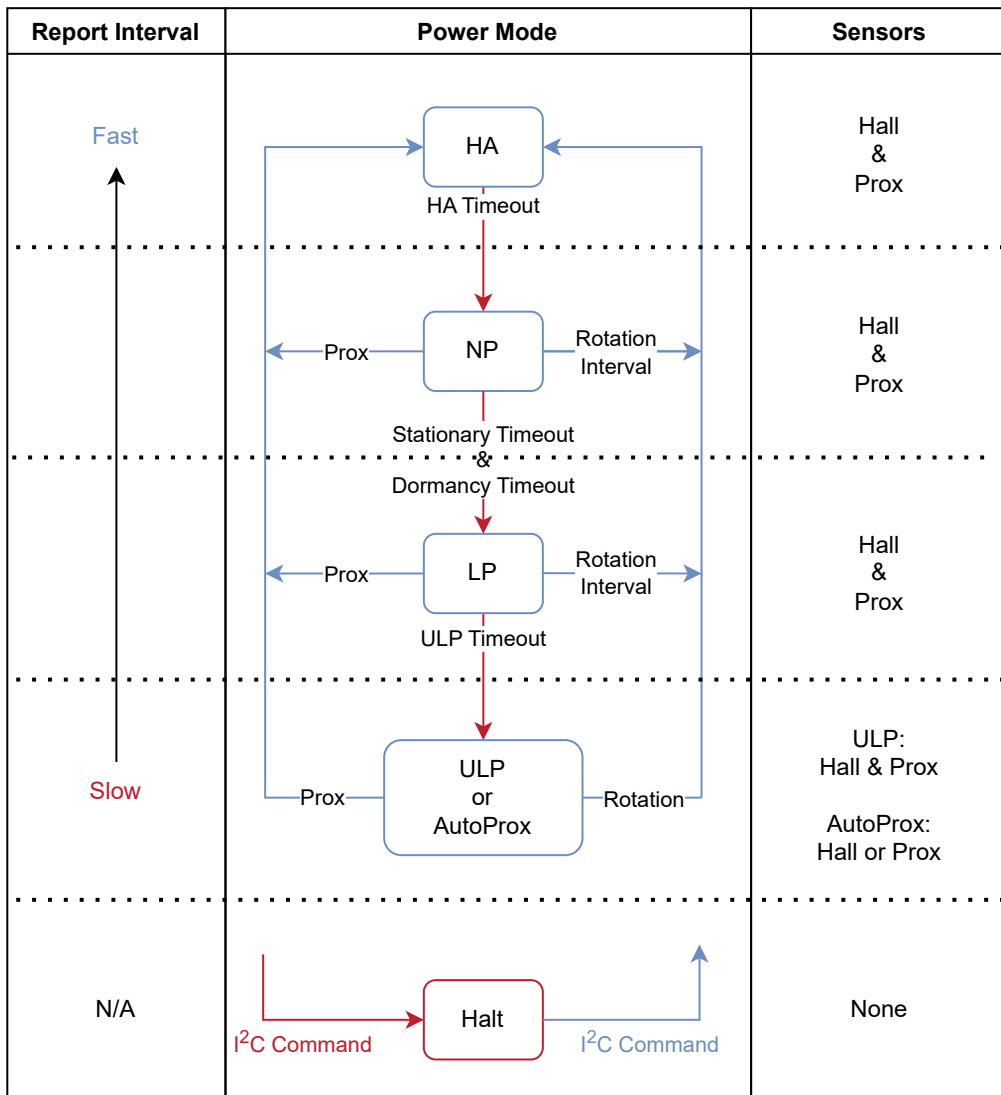

Figure 7.1: Power Modes

7.2 AutoProx

The IQS324 can be configured to use AutoProx when entering ULP Mode to further reduce current consumption. AutoProx is a feature that allows the IC to sample a single channel and perform basic limit checks on the counts, without running any power-intensive UIs or calculations. The channel then acts as a basic wake-up sensor. If the counts exceed the configured limit, the IQS324 will wake up and perform a full measurement and processing cycle.

AutoProx is enabled by setting the *AutoProx Enable* bit in the *ULP And Watchdog Settings* register. The wake-up channel can be selected as either the ProxFusion channel, or one of the Hall channels. This allows the IC to wake up on either a touch event, or when the magnet is rotated.

Note that AutoProx then replaces the regular ULP mode, and samples at the same rate as the ULP report rate. AutoProx should only be used with the Power Mode set to 'Auto'.



7.2.1 AutoProx Limits

The AutoProx counts limit is set in the *AutoProx Threshold* register. Typical threshold values lie between 100 and 500 counts.

For the ProxFusion channel, the AutoProx threshold may be set to the same value as the *ProxFusion LTA Halt Threshold*.

For the Hall channels, the threshold can be chosen based on the size of the swing on the Hall channels, as well as the interval size. Ideally, the IQS324 should wake up within half an interval of rotation. For example, with 24 intervals (15° per interval) the device should wake up after a rotation of 7.5° or less. If the Hall Gain is adjusted to get ±4000 counts of swing on the Hall channels, the maximum allowed AutoProx limit is

$$\text{Max Threshold} = 4000 \sin(7.5^\circ) = 522.$$

Note that certain invalid AutoProx Threshold configurations may result in an *AutoProx Error*, which is indicated in the *Device Status* register. At design time, it should be ensured that the chosen threshold does not cause this error flag to be set.

Note that if the AutoProx error flag is set during runtime, the IQS324 will fall back to performing regular measurements rather than AutoProx conversions while in ULP. Please contact Azoteq for more information.

7.2.2 AutoProx Update Rate

After a certain number of AutoProx measurements, the IQS324 will automatically wake up and sample all channels for a single cycle. This is configured in the *ULP and Watchdog Settings* register, and can be configured to wake the device up periodically after 4, 8, 16, or 32 AutoProx measurements.



8 Additional Features

8.1 Debug and Display Software (GUI)

The Azoteq IQS324 GUI can be utilised to configure the optimal settings required for a specific hardware setup or application. The device performance can be easily monitored and evaluated in the graphical environment until the optimal device configuration is obtained.

Once the IQS324 is configured in the GUI as desired, a C header file (.h file) can be exported that stores the values of all the read-write registers of the IQS324. The .h file displays the start address of each block of data, with each address containing one byte. An example of the .h file exported by the GUI is shown below.

```
/* Change the System Control Settings */  
/* Memory Map Position 0x1000 - 0x1011 */  
#define AUTO_CLEAR_SETTINGS          0x00  
#define SETTINGS_0                   0xC4  
...
```

8.2 Main Oscillator

The main oscillator frequency can be configured for 14 MHz or 18 MHz. This is configured in the [Power Settings](#) register. The lower-frequency configuration reduces the requirements on VDD, as shown in Section 3.3.

The higher-frequency configuration allows for larger amplification of the Hall plate signals, reducing noise in situations with low magnetic fields. This can be achieved by setting the [Hall Plate Bias](#) register to a higher value. The following table provides recommended values:

Table 8.1: Recommended Hall Bias Values for Different f_{OSC} Values

f_{OSC} [MHz]	Hall Bias Value
14	30
18	37

8.3 Watchdog Timer (WDT)

A software watchdog timer is implemented to improve system reliability. The watchdog timer is reset at the start of the main loop before any measurements take place. If the timer expires, the device is reset, performing a soft reboot. The *Watchdog Period* in the [Watchdog Settings](#) register determines the period of the timer in milliseconds before the device will reset.

Note: Ensure that the watchdog timeout period is greater than the I²C timeout period.

8.4 Reset

8.4.1 Reset Indication

After a reset, the *Show Reset* bit in the [Device Status](#) register will be set by the system to indicate that the reset event occurred. This device reset bit will clear when the master sets the *Ack Reset* bit in the [System Commands](#) register. If the Show Reset bit becomes set again, the master will know a reset has occurred and can react appropriately.



8.4.2 Software Reset

The IQS324 can be reset by means of an I²C command, by setting the *Soft Reset* bit in the *System Commands* register.



9 I²C Interface

9.1 I²C Module Specification

The device features a standard two-wire I²C interface, complemented by a RDY (ready interrupt) line, supporting a maximum bit rate of up to 1 Mbit/s. The memory structures accessible over the I²C interface are byte-addressable with 16-bit address values. 16-bit or 32-bit values are packed with little-endian byte order and are stored in word-aligned addresses.

- > Standard two-wire interface with RDY interrupt line
- > *Fast-Mode Plus* I²C with up to 1 Mbit/s bit rate
- > 7-bit device address
- > 16-bit little-endian register addressing
- > One data byte stored per register address

9.2 I²C Address

The IQS324 has a default I²C address of 0x54 (0b1010100). The full address byte will thus be 0xA8 (write) or 0xA9 (read).

9.2.1 Reserved I²C Address

When communicating with the IQS324, it will acknowledge (ACK) communication attempts made to an additional address derived from its slave address. This derived address is obtained by flipping the least significant bit of the slave address.

For example, with the default slave address of 0x54, the derived address would be 0x55 (0b1010101), obtained by changing the LSB from '0' to '1'. This derived address is reserved for internal use and should not be used. Even though the device will acknowledge communication attempts to this address, it will not function as normal, and should therefore be avoided.

9.3 I³C Compatibility

This device is not compatible with an I³C bus due to clock stretching allowed for data retrieval.

9.4 Memory Map Addressing

All memory locations are 16-bit addressable in little-endian byte order.

9.5 Memory Map Data

Each 16-bit memory map address stores a single byte (8 bits), making the memory map byte-addressable. Since the data is packed in a little-endian sequence, a 16-bit value starting at, for example, address 0x1014 will have its least significant byte at address 0x1014 and its most significant byte at address 0x1015.

9.6 RDY/IRQ

The IQS324 has an open-drain active low RDY signal to inform the master that updated data is available. The IQS324 will pull the RDY line low to indicate that it has opened a communications window, or "RDY window", for the master to read the new updated data. While the master can communicate



with the device at any time according to the *Force Comms Method*, it is recommended to use the RDY signal for optimal power consumption. Integrating the RDY signal as an interrupt input allows the master MCU to read and write data efficiently.

The device provides both streaming and event modes. In streaming mode, the RDY line toggles continuously, with each sensing cycle, whereas in event mode the RDY toggles only when specific events occurs. The types of events that trigger the RDY window are configurable in the *Event Mask* register.

9.7 Read and Write Operations

9.7.1 I²C Read From Specific Address

A typical read operation is displayed in Figure 9.1. The master device waits for the RDY line of the IQS324 to go low, indicating the availability of new data and an available communication window. Once the RDY interrupt is triggered, the master initiates communication by sending a start condition followed by the device address and a write command. The IQS324 responds with an acknowledgement, after which the master device will transmit two bytes defining the register address. The master then sends a repeated start condition, followed by the device address with a read command. The IQS324 transmits data from the requested address and will continue to do so while the master acknowledges each byte. The read operation is ended when the master does not acknowledge the last byte received and produces a stop condition.

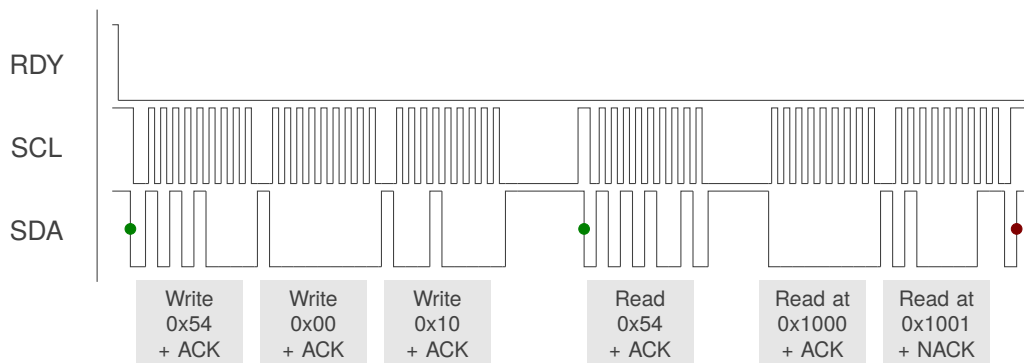

Figure 9.1: I²C Read Example — Read Status Registers 0x1000 and 0x1001

9.7.2 I²C Write To Specific Address

The write operation is displayed in Figure 9.2. Similar to the read transaction, when the RDY interrupt is triggered, the master initiates communication by sending a start condition followed by the device address and a write command. The IQS324 responds with an acknowledgement, after which the master device transmits two bytes defining the register address. The slave acknowledges the register address bytes. The master may then write a series of bytes to the register address and the addresses that follow, with each byte being acknowledged by the slave. The write operation is ended when the master produces a stop condition.

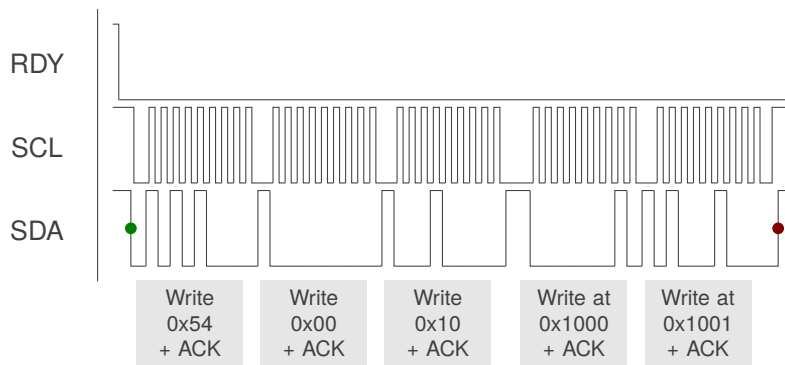

Figure 9.2: I²C Write Example — Write Two Bytes to Button Settings Registers 0x1000 and 0x1001

9.7.3 Modifying Bits Over I²C

When modifying individual bits in a register, it is recommended to read the register first, make the necessary modifications, and then write the updated value back to the IQS324 register to prevent unintentional bit changes.

For example, setting the *Ack Reset* bit and *Power Mode* setting would involve:

- > Read the *System Control* Registers (0x1000 and 0x1001) as illustrated in Figure 9.1.
- > Set the *Ack Reset* bit using the bitwise OR operator. For example:

$$\text{READ_VALUE OR } 0x01$$

- > Set the *Power Mode* setting by clearing the bit field using a bitwise AND operation, then setting the bit field value with an OR operation. For example, to set the *Power Mode* to 'Auto':

$$(\text{READ_VALUE AND } 0xF8) \text{ OR } 0x04$$

- > Write the new values back over I²C, as shown in Figure 9.2.

Read-modify-write transactions should be done in a single communication window, using I²C restart conditions. Please refer to Section 9.9 for more information regarding multiple I²C transactions in a single communication window.

9.8 I²C Timeout

If the communication window is not serviced within the *I²C Timeout* period (in milliseconds), the session is ended (RDY goes HIGH), and processing continues as normal. This allows the system to continue and keep reference values up to date even if the master is not responsive. However, the corresponding data will be lost, so this should be avoided. The default I²C timeout period is set to 250 ms.

9.9 Terminate Communication

With the *Terminate Comms Window* setting enabled in the *Power Settings* register, a standard I²C STOP ends the current communication window. If multiple I²C transactions need to be done, then they should be strung together using repeated-start conditions instead of giving a STOP. Allowing an I²C STOP to terminate the communication window is the recommended method, as illustrated in Figures 9.1 and 9.2.



This behaviour can be temporarily disabled by clearing the *Terminate Comms Window* setting. In this case, an I²C STOP will NOT terminate the communication window. Instead, the communication window can be closed manually, as desired, by setting the *Terminate Comms Window* bit as the final I²C transaction, followed by a STOP.

9.10 Invalid Communications Return

The device will give an invalid communication response (0xEE) under the following conditions:

- > The host is trying to read from a memory map register that does not exist.
- > The host is trying to read from the device outside a communication window (while RDY is high).

9.11 Event Mode Communication

The device can be set up to bypass the communication window when no activity is sensed by setting the *Event Mode* bit in the *Power Settings* register. This is usually enabled since the master does not need to be interrupted unnecessarily during every cycle if no activity occurs. The communication will resume (RDY will indicate available data) if an enabled event occurs. It is recommended that the RDY be placed on an interrupt-on-pin-change input on the master.

Event mode can only be entered if the following requirements are met:

- > Events must be serviced by reading from the *Event Flags* register to ensure all events flags are cleared, otherwise continuous reporting (RDY interrupts) will persist after every cycle, similar to streaming mode.
- > The *Show Reset* bit in the *Device Status* register has been cleared by setting the *Ack Reset* bit in *System Commands*.

9.11.1 Events

Numerous events can be individually enabled in the *Event Mask* register to trigger communication in Event Mode:

- > Power mode changes
- > ATI events
- > Touch/button events
- > Movement detection
- > Hall rotation event

9.11.2 Force Communication

In streaming mode, the IQS324 I²C will provide RDY windows at regular intervals specified by the relevant power mode report rate. This will provide the master with regular opportunities to perform I²C communication as necessary.

If the device is placed in Event Mode or Halt Mode, the IQS324 will not open RDY windows unless certain conditions are met. A new RDY window can be requested by writing 0xFF over I²C, followed by a stop condition. After a short delay, the IQS324 will pull the RDY line low and open a new communication window. This is shown in Figure 9.3.

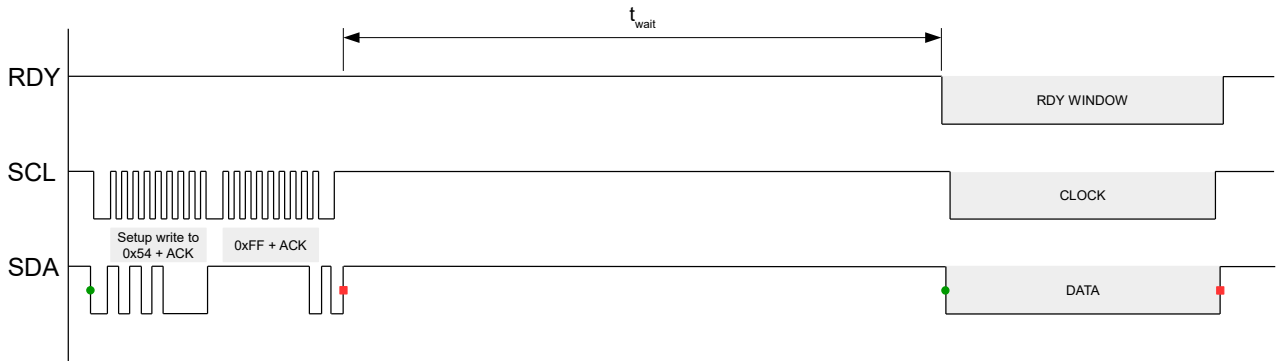

Figure 9.3: Force Comms Diagram

After a short delay, a new communication window will be made available, indicated by the RDY signal. The delay between the communication request and the opening of a RDY window (t_{wait}) is application specific, but will typically be under 2 milliseconds.



10 I²C Memory Map

Table 10.1: I²C Memory Map

Address	Length	Description	Default	Notes
Read-Only	No. Bytes	Version Info		
0x00	2	Product Number	2389	
0x01				
0x02	2	Major Version	1	
0x03				
0x04	2	Minor Version	2	
0x05				
Read-Write	No. Bytes	System Control Settings		
0x1000	1	System Commands	0	Section A.1
0x1001	1	Power Settings	196	Section A.2
0x1002	1	Event Masks	29	Section A.3
0x1003	1	ULP and Watchdog Settings	115	Section A.4
0x1004	2	AutoProx Threshold	200	
0x1005				
0x1006	2	HA Report Rate	2	0 – 3000
0x1007				
0x1008	2	NP Report Rate	20	0 – 3000
0x1009				
0x100A	2	LP Report Rate	100	0 – 3000
0x100B				
0x100C	2	ULP Report Rate	500	0 – 3000
0x100D				
0x100E	2	ULP Timeout	5000	
0x100F				
0x1010	2	I ² C Timeout	250	
0x1011				
Read-Write	No. Bytes	ProxFusion® Settings		
0x1014	1	ProxFusion Settings 0	203	Section A.5
0x1015	1	ProxFusion Settings 1	55	Section A.6
0x1016	2	Button Touch Timeout	8000	
0x1017				
0x1018	2	Button Dormancy Timeout	4000	
0x1019				
0x101A	2	Button ATI Timeout	1000	
0x101B				
0x101C	1	Counts Filter Beta	2	0 – 15
0x101D	1	LTA Filter Beta	8	0 – 15
0x101E	1	Fast LTA Filter Beta	4	0 – 15
0x101F	1	LP LTA Filter Beta	10	0 – 15
0x1020	2	Fast LTA Filter Band	5	
0x1021				



Table 10.1: I²C Memory Map (Continued)

0x1022	2	Button Threshold	500	
0x1023				
0x1024	1	Button Debounce	18	Section A.7
0x1025	1	Button Hysteresis	20	
0x1026	2	Movement Threshold	200	
0x1027				
0x1028	1	Movement Debounce	18	Section A.8
0x1029	1	Movement Hysteresis	100	
0x102A	2	ProxFusion ATI Band	1000	
0x102B				
0x102C	2	LTA Halt Threshold	100	
0x102D				
Read-Write	No. Bytes	ProxFusion® ATI Settings		
0x102E	2	ProxFusion ATI Base	15000	
0x102F				
0x1030	2	ProxFusion ATI Target	6500	
0x1031				
0x1032	2	ProxFusion Dividers		Section A.9
0x1033				
0x1034	2	ProxFusion Compensation		
0x1035				
Read-Write	No. Bytes	Hall Sensor Settings		
0x1036	2	Hall Plate Offset NW		
0x1037				
0x1038	2	Hall Plate Offset NE		
0x1039				
0x103A	2	Hall Plate Offset SE		
0x103B				
0x103C	2	Hall Plate Offset SW		
0x103D				
0x103E	2	Hall Dividers	19942	Section A.10
0x103F				
0x1040	2	Hall Target	13000	
0x1041				
0x1042	2	Hall ATI Band	2000	
0x1043				
0x1044	1	Hall Plate Bias	222	Section A.11
0x1045	1	Hall General Settings	91	Section A.12
0x1046	1	Reserved	3	
0x1047	1	Hall Init Length	3	Section A.13
0x1048	2	Phase Angle Sin		
0x1049				
0x104A	2	Phase Angle Cos		
0x104B				
Read-Write	No. Bytes	Hall UI Settings		
0x1062	1	Hall UI Settings	20	Section A.14

Continued on next page...



Table 10.1: I²C Memory Map (Continued)

0x1063	1	Reserved	0	
0x1064	2	Wheel To Magnet Angle Offset		
0x1065				
0x1066	2	High Accuracy Timeout	300	
0x1067				
0x1068	2	Stationary Timeout	5000	
0x1069				
0x106A	1	Auto Zero Beta	1	0 – 15
0x106B	1	Angle Filter Beta	12	0 – 31
0x106C	1	LP Angle Filter Beta	20	0 – 31
0x106D	1	CORDIC Resolution	14	
Read-Write	No. Bytes	Interval UI Settings		
0x106E	2	Number of Intervals	24	
0x106F				
0x1070	2	Interval Hysteresis	250	Same unit as Processed Angle
0x1071				
0x1072	2	Reserved	0	
0x1073				
Read-Write	No. Bytes	Hall Normalisation Settings		
0x1074	1	Normalisation Beta	2	0 – 15
0x1075	1	Normalisation Mode	1	Section A.15

Continued on next page...



Table 10.1: I²C Memory Map (Continued)

Read-Only	No. Bytes	System Flags	
0x2000	1	Power Mode Flags	Section A.16
0x2001	1	Device Status	Section A.17
0x2002	1	Hall Flags	Section A.18
0x2003	1	Event Flags	Section A.19
0x2004	1	ProxFusion® States	Section A.20
0x2005	1	Reserved	
0x2006	1	Button Event Flags	Section A.21
0x2007	1	Movement Event Flags	Section A.22
Read-Only	No. Bytes	Hall Field Data	
0x2008	2	Hall Plate Reference NW	
0x2009			
0x200A	2	Hall Plate Reference NE	
0x200B			
0x200C	2	Hall Plate Reference SE	
0x200D			
0x200E	2	Hall Plate Reference SW	
0x200F			
0x2010	4	Hall Field Buffer NW	Signed 32-bit value
0x2011			
0x2012			
0x2013			
0x2014	4	Hall Field Buffer NE	Signed 32-bit value
0x2015			
0x2016			
0x2017			
0x2018	4	Hall Field Buffer SE	Signed 32-bit value
0x2019			
0x201A			
0x201B			
0x201C	4	Hall Field Buffer SW	Signed 32-bit value
0x201D			
0x201E			
0x201F			
0x2020	4	Field Differential A	Signed 32-bit value
0x2021			
0x2022			
0x2023			
0x2024	4	Field Differential B	Signed 32-bit value
0x2025			
0x2026			
0x2027			

Continued on next page...



Table 10.1: I²C Memory Map (Continued)

Read-Only	No. Bytes	Hall Counts		
0x202A	2	Hall Counts NW		
0x202B				
0x202C	2	Reserved		
0x202D				
0x202E	2	Hall Inverse Counts NW		
0x202F				
0x2030	2	Reserved		
0x2031				
0x2032	2	Hall Counts NE		
0x2033				
0x2034	2	Reserved		
0x2035				
0x2036	2	Hall Inverse Counts NE		
0x2037				
0x2038	2	Reserved		
0x2039				
0x203A	2	Hall Counts SE		
0x203B				
0x203C	2	Reserved		
0x203D				
0x203E	2	Hall Inverse Counts SE		
0x203F				
0x2040	2	Reserved		
0x2041				
0x2042	2	Hall Counts SW		
0x2043				
0x2044	2	Reserved		
0x2045				
0x2046	2	Hall Inverse Counts SW		
0x2047				
Read-Only	No. Bytes	ProxFusion® Counts		
0x204A	2	ProxFusion® Counts		
0x204B				
0x204C	2	ProxFusion® Filtered Counts		
0x204D				
0x204E	2	Reserved		
0x204F				
0x2050	2	ProxFusion® Button LTA		
0x2051				
0x2052	2	Reserved		
0x2053				
0x2054	2	ProxFusion® Movement LTA		
0x2055				
0x2056	2	Reserved		
0x2057				

Continued on next page...



Table 10.1: I²C Memory Map (Continued)

0x2058	2	ProxFusion® Button Delta		Signed 16-bit value
0x2059				
0x205A	2	ProxFusion® Movement Delta		Signed 16-bit value
0x205B				
Read-Only	No. Bytes	Hall Rotation Data		
0x2064	2	Current Interval		
0x2065				
0x2066	2	Interval Upper Limit		Same unit as Processed Angle
0x2067				
0x2068	2	Interval Lower Limit		Same unit as Processed Angle
0x2069				
0x206A	2	Processed Angle		0 – 65536 → 0° – 360°
0x206B				
0x206C	2	Absolute Angle		0 – 65536 → 0° – 360°
0x206D				
Read-Only	No. Bytes	Hall Normalisation Data		
0x206E	4	Normalised Hall Field A		Signed 32-bit value
0x206F				
0x2070				
0x2071				
0x2072	4	Normalised Hall Field B		Signed 32-bit value
0x2073				
0x2074				
0x2075				
0x2076	2	Minimum Hall Field A		Unsigned 16-bit value
0x2077				
0x2078	2	Reserved		
0x2079				
0x207A	2	Minimum Hall Field B		Unsigned 16-bit value
0x207B				
0x207C	2	Reserved		
0x207D				
0x207E	2	Maximum Hall Field A		Unsigned 16-bit value
0x207F				
0x2080	2	Reserved		
0x2081				
0x2082	2	Maximum Hall Field B		Unsigned 16-bit value
0x2083				
0x2084	2	Reserved		
0x2085				



11 Ordering Information

11.1 Ordering Code

IQS324 zzz ppb

Table 11.1: Order Code Description

IC NAME			IQS324
CONFIGURATION	zzz	=	001 I ² C address: 0x54
PACKAGE TYPE	pp	=	QF QFN-20 Package
BULK PACKAGING	b	=	R QFN-20 Reel (2000 pcs/reel)

Example : IQS324001QFR

11.2 Top Marking

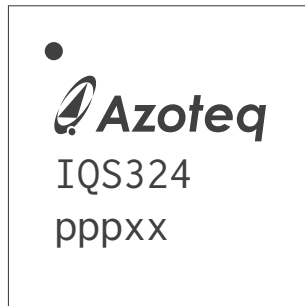

“IQS324” = Product Name

“ppp” = Product Code

“xx” = Batch Code

Figure 11.1: IQS324-QFN20 Package Top Marking



“IQS3hd” = Product Name

“ppp” = Product Code

“xx” = Batch Code

Figure 11.2: QFN20 Generic Package Top Marking



12 Package Information

12.1 QFN20 Package Outline

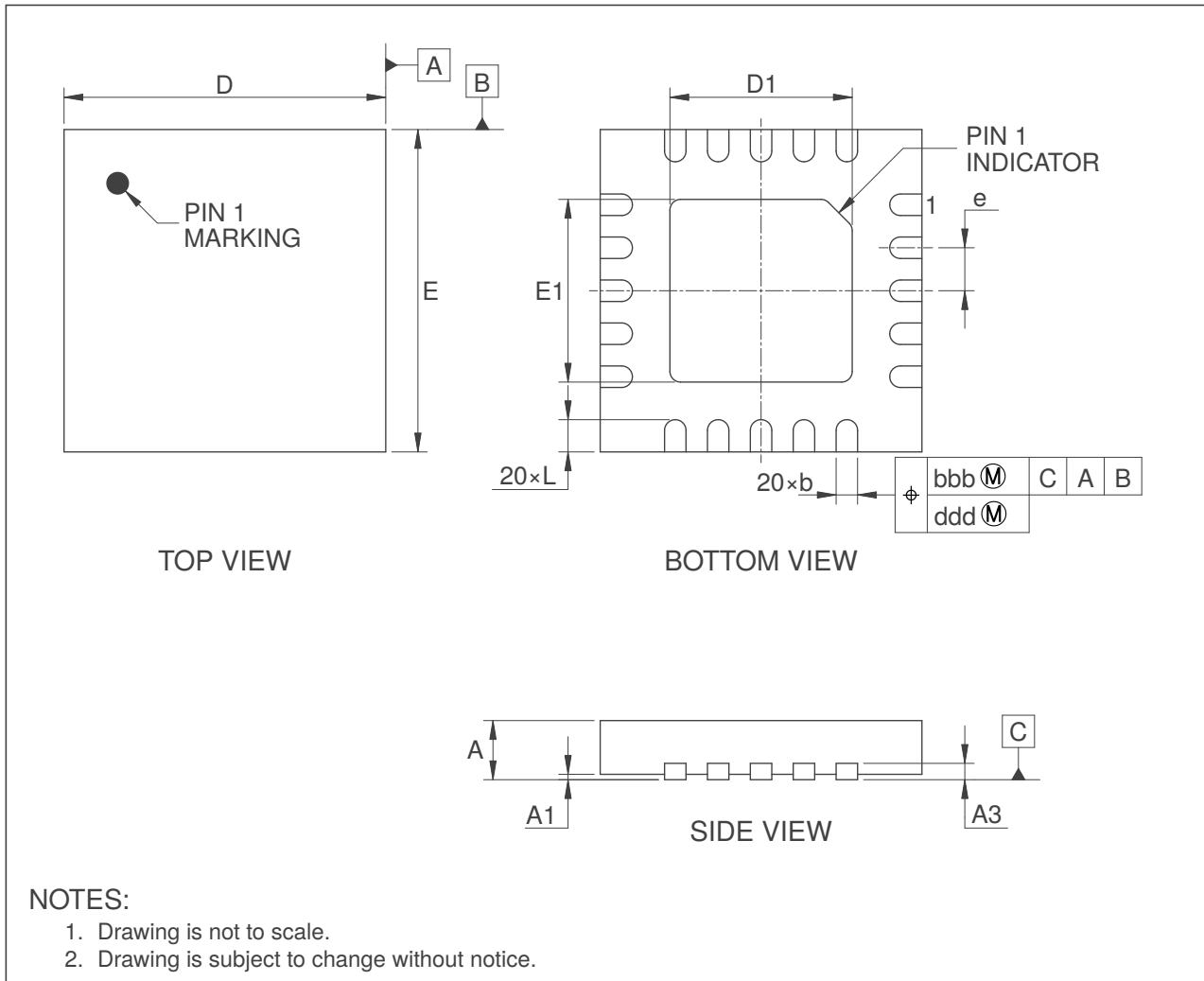

Figure 12.1: QFN20 Package Outline



Table 12.1: QFN20 Package Dimensions [mm]

Dimension	Millimeters		
	Min	Typ	Max
A	0.50	0.55	0.60
A1	0.00	0.02	0.05
A3	0.152 REF		
b	0.15	0.20	0.25
D	3.00 BSC		
E	3.00 BSC		
D1	1.60	1.70	1.80
E1	1.60	1.70	1.80
e	0.40 BSC		
L	0.25	0.30	0.35

Table 12.2: QFN20 Package Tolerances [mm]

Tolerance	Millimeters
bbb	0.07
ddd	0.05

12.3 Tape and Reel Specifications

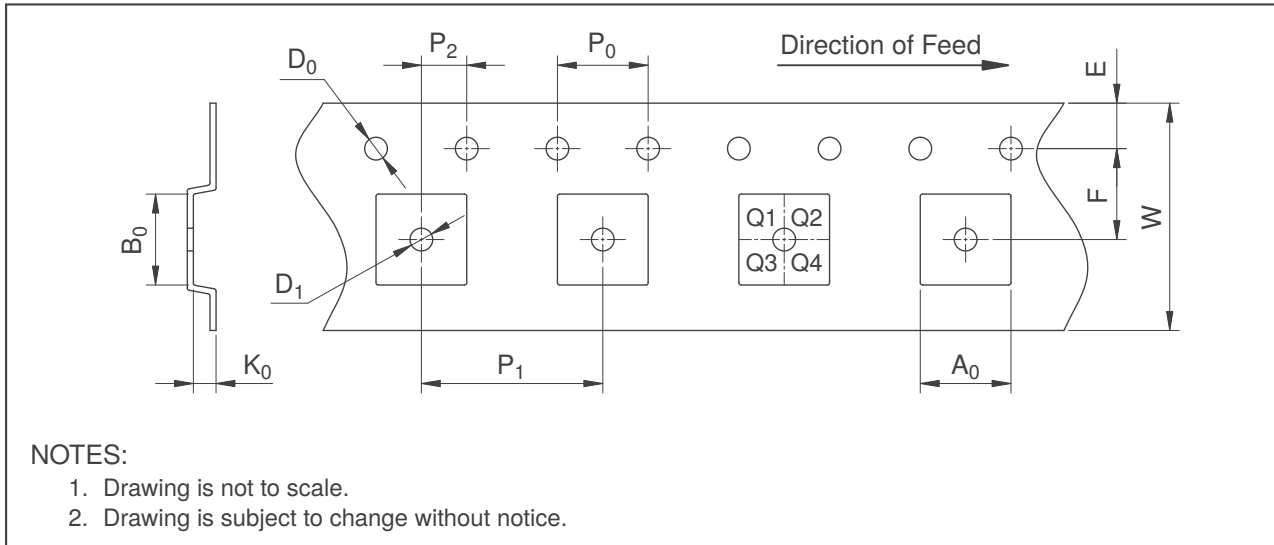

Figure 12.3: Carrier Tape Specification

Table 12.3: Carrier Tape Dimensions [mm]

Dimension	Package
	QFN20
A ₀	3.30
B ₀	3.30
K ₀	0.75
D ₀	1.50
D ₁	1.55
E	1.75
F	5.50
P ₀	4.00
P ₁	8.00
P ₂	2.00
W	12.00
Pin 1 Quadrant	Q2

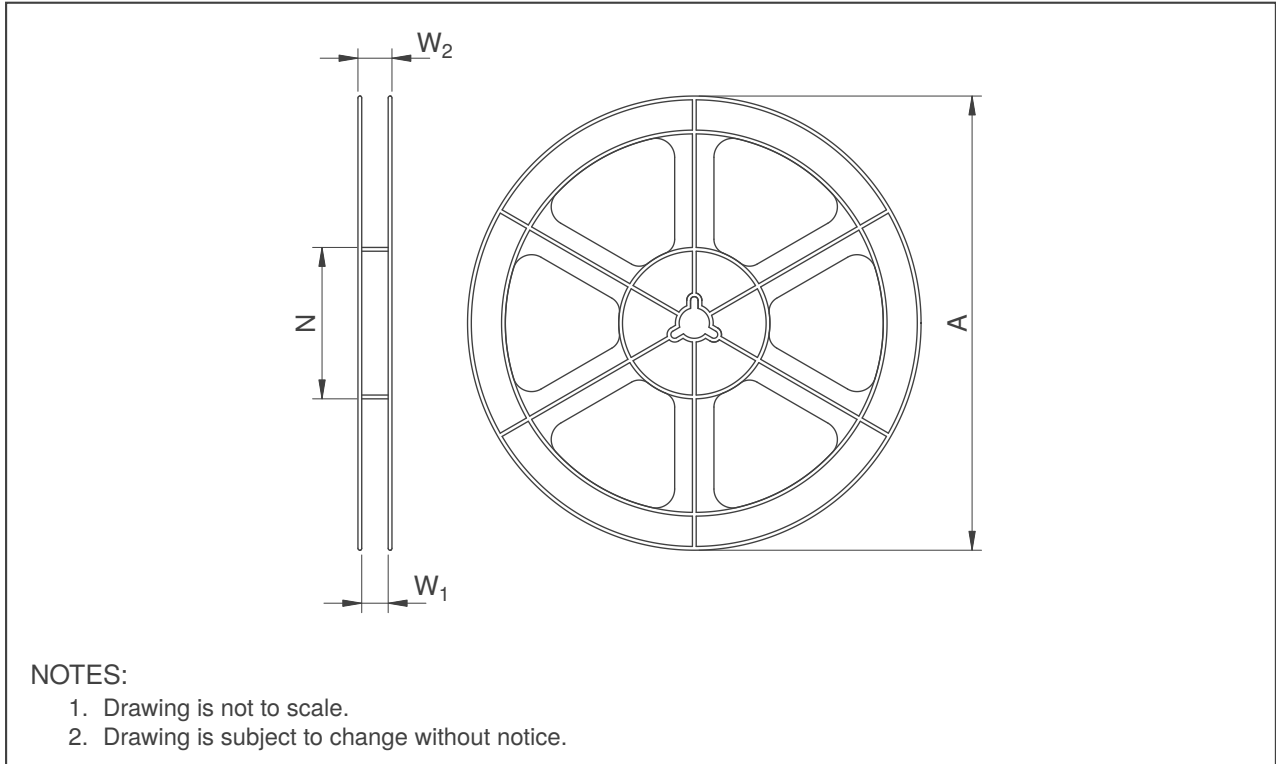

Figure 12.4: Reel Specification

Table 12.4: Reel Dimensions [mm]

Dimension	Package
	QFN20
A	178
N	60
W ₁	12.4
W ₂ (Max)	18.4



A Memory Map Descriptions

A.1 System Commands (0x1000)

Bit	7	6	5	4	3	2	1	0
Description	Reserved		Reseed Proxfusion Channel	Zero	ATI Hall	ATI ProxFusion Channel	Soft Reset	Ack Reset

> Bit 5: **Reseed Proxfusion Channel**

- 0: No action
- 1: Reseed the Proxfusion channel LTA
- Bit automatically cleared

> Bit 4: **Zero**

- 0: No action
- 1: Set the processed Hall angle to the centre of interval 0
- Bit automatically cleared

> Bit 3: **ATI Hall**

- 0: No action
- 1: Perform ATI calibration of the Hall channels
- Bit automatically cleared

> Bit 2: **ATI ProxFusion Channel**

- 0: No action
- 1: Perform ATI calibration of the ProxFusion channel
- Bit automatically cleared

> Bit 1: **Soft Reset**

- 0: No action
- 1: Soft reset the device
- Bit automatically cleared

> Bit 0: **Ack Reset**

- 0: No action
- 1: Acknowledge a device reset
- Bit automatically cleared

A.2 Power Settings (0x1001)

Bit	7	6	5	4	3	2	1	0
Description	Terminate Comms	Event Mode	Reserved		FOSC Select	Power Mode Setting		

> Bit 7: **Terminate Comms on Stop**

- 0: Keep I²C communications window open on I²C stop condition
- 1: Close I²C communications window on I²C stop condition

> Bit 6: **Event Mode**

- 0: Streaming mode enabled. An I²C communications window is opened every cycle.
- 1: Event mode enabled. An I²C communications window is opened only if an enabled event occurs.

> Bit 3: **f_{osc} Select**

- 0: 14 MHz
- 1: 18 MHz

> Bit 0-2: **Power Mode Setting**

- 0: High Accuracy
- 1: Normal Power
- 2: Low Power
- 3: Ultra Low Power
- 4: Auto



- 7: Halt

A.3 Event Masks (0x1002)

Bit	7	6	5	4	3	2	1	0
Description	Reserved			Hall Interval	Movement	Button	ATI	Power Mode

- > Bit 4: **Hall Interval**
 - 0: Disabled
 - 1: Open an I²C communications window on Hall interval changes
- > Bit 3: **Movement**
 - 0: Disabled
 - 1: Open an I²C communications window on Movement events
- > Bit 2: **Button**
 - 0: Disabled
 - 1: Open an I²C communications window on Button events
- > Bit 1: **ATI**
 - 0: Disabled
 - 1: Open an I²C communications window on ATI events
- > Bit 0: **Power Mode**
 - 0: Disabled
 - 1: Open an I²C communications window on power mode changes

A.4 ULP and Watchdog Settings (0x1003)

Bit	7	6	5	4	3	2	1	0
Description	Disable Read-Only Check	Watchdog Period			AutoProx Channel	AutoProx Enable	AutoProx Conversion Setting	

- > Bit 7: **Disable Read-Only Check**
 - 0: Disabled
 - 1: Enabled
- > Bit 4-6: **Watchdog Period**
 - 0: Off
 - 1: 50 ms
 - 2: 125 ms
 - 3: 250 ms
 - 4: 500 ms
 - 5: 1000 ms
 - 6: 2000 ms
 - 7: 4000 ms
- > Bit 3: **AutoProx Channel**
 - 0: Use ProxFusion channel as wake-up channel in AutoProx mode
 - 1: Use Hall channels as wake-up channel in AutoProx mode
- > Bit 2: **AutoProx Enable**
 - 0: AutoProx disabled
 - 1: AutoProx enabled
- > Bit 0-1: **AutoProx Conversion Setting**
 - 0: Update all channels and UIs after 4 AutoProx conversions
 - 1: Update all channels and UIs after 8 AutoProx conversions
 - 2: Update all channels and UIs after 16 AutoProx conversions
 - 3: Update all channels and UIs after 32 AutoProx conversions



A.5 ProxFusion Settings 0 (0x1014)

Bit	7	6	5	4	3	2	1	0
Description	ATI Mode		Dual Threshold	Inverse	Reserved			

> Bit 6-7: **ATI Mode**

- 0: Disabled
- 1: Divider Only
- 2: Compensation Only
- 3: Divider And Compensation

> Bit 5: **Dual Threshold**

- Allow button events to trigger for both positive and negative delta values
- 0: Disabled
- 1: Enabled

> Bit 4: **Inverse**

- Set button events to trigger for negative deltas. May be necessary for inductive sensing.
- 0: Disabled
- 1: Enabled

A.6 ProxFusion Settings 1 (0x1015)

Bit	7	6	5	4	3	2	1	0
Description	FOSC Tx	Sensing Mode			Button Conversion Frequency			

> Bit 7: **f_{osc} Tx**

- 0: Disabled
- 1: Run sensor with TX at f_{osc} frequency. Recommended only for inductive sensing.

> Bit 4-6: **Sensing Mode**

- 0: Disabled
- 3: Self-Capacitance
- 4: Inductance

> Bit 0-3: **Conversion Frequency**

The following are recommended example values:

- 0: 7 MHz / 9 MHz
- 1: 3.5 MHz / 4.5 MHz
- 3: 1.750 MHz / 2.25 MHz
- 7: 0.875 MHz / 1.125 MHz
- 15: 0.4375 MHz / 0.5625 MHz

Note: The maximum recommended conversion frequency for capacitive sensing is 1 MHz.

A.7 Button Debounce (0x1024)

Bit	7	6	5	4	3	2	1	0
Description	Debounce Exit				Debounce Enter			

> Bit 4-7: **Debounce Exit**

- 4-bit value
- Number of high-frequency samples while exiting Button state

> Bit 0-3: **Debounce Enter**

- 4-bit value
- Number of high-frequency samples while entering Button state



A.8 Movement Debounce (0x1028)

Bit	7	6	5	4	3	2	1	0
Description	Debounce Exit				Debounce Enter			

- > Bit 4-7: **Debounce Exit**
 - 4-bit value
 - Number of high-frequency samples while exiting Movement state
- > Bit 0-3: **Debounce Enter**
 - 4-bit value
 - Number of high-frequency samples while entering Movement state

A.9 ProxFusion Dividers (0x1032)

Bit	15	14	13	12	11	10	9	8	
Description	Reserved		Fine Divider					Coarse Gain	

Bit	7	6	5	4	3	2	1	0
Description	Coarse Gain							

- > Bit 9-13: **Fine Divider**
 - 5-bit value
- > Bit 0-8: **Coarse Gain**
 - 9-bit value
 - Coarse Gain can be chosen based on the following values:

Table A.1: Coarse Gain Recommended Values

Gain Ratio	Register Value
4.00	258
2.00	130
1.00	66
0.50	68
0.43	206
0.29	71
0.14	78
0.07	91

A.10 Hall Dividers (0x103E)

Bit	15	14	13	12	11	10	9	8
Description	Hall Divider							

Bit	7	6	5	4	3	2	1	0
Description	Hall Divider							

- > Bit 0-15: **Hall Divider**
 - Hall Gain can be chosen based on the following values:



Table A.2: Hall Divider Recommended Values

Gain Ratio	Register Value
3.00	0x4721
2.25	0x4921
1.33	0x4702
0.82	0x5721
0.47	0x6721
0.29	0x4E82
0.25	0x4DE6
0.17	0x4644
0.10	0x4A44

A.11 Hall Plate Settings (0x1044)

Bit	7	6	5	4	3	2	1	0
Description	Hall Amp Gain		Hall Plate Bias					

> Bit 6-7: **Hall Amplifier Gain**

- 2-bit value
- 0: x1
- 1: x2
- 2: x4
- 3: x8

> Bit 0-5: **Hall Plate Bias**

- 6-bit value
- Refer to Table 8.1

A.12 Hall General Settings (0x1045)

Bit	7	6	5	4	3	2	1	0
Description	Hall At FOSC	Runtime ATI	Magnet Orientation				Reserved	

> Bit 7: **Hall At FOSC**

- 0: Disabled
- 1: Run Hall measurements at f_{OSC} frequency.

> Bit 6: **Runtime ATI**

- 0: Disabled
- 1: Enabled

> Bit 1-5: **Magnet Orientation**

- 1: Off-axis N-S axis
- 17: Off-axis W-E axis
- 11: Off-axis NW to SE diagonal axis
- 13: Off-axis NE to SW diagonal axis
- 6: Hall sensing disabled

A.13 Hall Init Length (0x1047)

Bit	7	6	5	4	3	2	1	0
Description	Reserved				Hall Init Length			

> Bit 0-2: **Hall Init Length**



- 0: 8 counts
- 1: 16 counts
- 2: 32 counts
- 3: 64 counts
- 4: 256 counts (recommended)
- 5: 512 counts
- 6: 1024 counts
- 7: 2048 counts

A.14 Rotation UI Settings (0x1062)

Bit	7	6	5	4	3	2	1	0
Description	Reserved	Auto Zero Mode			Reserved		Reverse	Reserved

> Bit 4-6: **Auto Zero Mode**

- 0: Off
- 1: Stationary
- 2: Continuous
- 3: Stationary-Release
- 4: Continuous-Release

> Bit 1: **Reverse**

- 0: Disabled
- 1: Reverse direction of sampled rotation

A.15 Normalisation Mode (0x1075)

Bit	7	6	5	4	3	2	1	0
Description	Reserved						Norm Mode	

> Bit 0-1: **Normalisation Mode**

- 0: Off
- 1: Auto
- 2: Manual

A.16 Power Mode Flags (0x2000)

Bit	7	6	5	4	3	2	1	0
Description	Reserved						Power Mode	

> Bit 0-1: **Power Mode**

- 0: High Accuracy
- 1: Normal Power
- 2: Low Power
- 3: Ultra Low Power

A.17 Device Status (0x2001)

Bit	7	6	5	4	3	2	1	0
Description	Reserved						AutoProx Error	Show Reset

> Bit 1: **AutoProx Error**

- 0: Disabled



- 1: An error occurred with the AutoProx limits. The device will perform regular measurements rather than AutoProx conversions in Ultra Low power mode.

> **Bit 0: Show Reset**

- 0: Disabled
- 1: System reset event occurred

A.18 Hall Flags (0x2002)

Bit	7	6	5	4	3	2	1	0
Description	Reserved				High Accuracy	Stationary	Direction	Interval Change

> **Bit 3: High Accuracy**

- 0: Device not in high-accuracy mode
- 1: IQS324 sampling at high-accuracy report rate to avoid aliasing

> **Bit 2: Stationary**

- 0: Magnet moved recently. IQS324 samples at normal or high-accuracy report rate.
- 1: Magnet is considered stationary when interval has not changed for some time. IQS324 may transition to lower power mode.

> **Bit 1: Direction**

- 0: Interval change in negative direction
- 1: Interval change in positive direction

> **Bit 0: Interval Change**

- 0: No interval change occurred
- 1: Interval change occurred

A.19 Event Flags (0x2003)

Bit	7	6	5	4	3	2	1	0
Description	Reserved			Hall Interval	Movement Event	Button Event	ATI Event	Power Mode Event

> **Bit 4: Hall Interval**

- 0: No event
- 1: Interval change occurred
- Cleared on read

> **Bit 3: Movement Event**

- 0: No event
- 1: Movement event occurred
- Cleared on read

> **Bit 2: Button Event**

- 0: No event
- 1: Button event occurred
- Cleared on read

> **Bit 1: ATI Event**

- 0: No event
- 1: ATI event occurred
- Cleared on read

> **Bit 0: Power Mode Event**

- 0: No event
- 1: Power mode change occurred
- Cleared on read



A.20 Proxfusion States (0x2004)

Bit	7	6	5	4	3	2	1	0
Description	Reserved						ATI Error	Dormant

> Bit 1: **ATI Error**

- 0: No error
- 1: ProxFusion channel failed to calibrate correctly

> Bit 0: **Dormant**

- 0: Recent activity on the ProxFusion channel occurred
- 1: ProxFusion channel is considered dormant after some period of inactivity. Allows device to transition to a lower power mode.

A.21 Button Event Flags (0x2006)

Bit	7	6	5	4	3	2	1	0
Description	Reserved		Button Exit	Button Enter	LTA Halt	Debounce	Reserved	Button Event Active

> Bit 5: **Button Exit**

- 0: No event
- 1: "Button release" event. *Button Active* state transitioned from '1' to '0'.

> Bit 4: **Button Enter**

- 0: No event
- 1: "Button press" event. *Button Active* state transitioned from '0' to '1'.

> Bit 3: **LTA Halt**

- 0: LTA is filtering normally
- 1: LTA filter is halted to improve channel sensitivity

> Bit 2: **Button Debounce**

- 0: Button UI not currently debouncing
- 1: Button UI currently debouncing by sampling at high-accuracy report rate

> Bit 0: **Button Event Active**

- 0: Button UI delta currently below threshold
- 1: Button UI delta currently above threshold. Button is considered "pressed".

A.22 Movement Event Flags (0x2007)

Bit	7	6	5	4	3	2	1	0
Description	Reserved		Movement Exit	Movement Enter	Reserved	Debounce	Direction	Movement Active

> Bit 5: **Movement Exit**

- 0: No event
- 1: "Release" event. *Movement Active* state transitioned from '0' to '1' with a negative delta.

> Bit 4: **Movement Enter**

- 0: No event
- 1: "Touch" event. *Movement Active* state transitioned from '0' to '1' with a positive delta.

> Bit 2: **Movement Debounce**

- 0: Movement UI not currently debouncing
- 1: Movement UI currently debouncing by sampling at high-accuracy report rate

> Bit 1: **Movement Direction**

- 0: Movement delta is less than 0
- 1: Movement delta is greater than 0



> Bit 0: **Movement Event Active**

- 0: No movement detected
- 1: Movement occurring on ProxFusion channel. The movement UI delta is currently above the threshold.



B Known Issues

B.1 Soft Reset During Force Comms

An I²C transaction that addresses the IQS324 outside a valid communication window, such as a force communication request when the RDY pin is high, may cause the IQS324 to soft reset. This reset risk is present in a short time window (over a few microseconds) at the end of each measurement cycle, when the IQS324 enters a deep sleep mode. The reset risk is only present for report periods higher than 5 ms.

Application MCU firmware should reliably be able to handle a reset condition and reconfigure the IQS324. This can be done by checking the state of the reset bit on every RDY window. An example of this can be found in the Arduino example code provided on Azoteq's website.

The following strategies can help reduce the likelihood of encountering the reset issue:

- > Make use of the IQS324's automatic communications windows as far as possible. Avoid addressing the IQS324 while the RDY pin is high, and keep force communication requests to a minimum.
- > If a large amount of data needs to be written to the IQS324 over multiple I²C transactions, enable the device's Streaming Mode and then write the data within the automatic RDY windows. Streaming mode is enabled by writing a 0 to the *Event Mode* bit in the *Power Settings* register. To re-enter Event Mode, write a 1 to the *Event Mode* bit.
- > Device addressing and force communication requests should not be performed within 300 μs of a previous communications window (after the RDY pin transitioned to HIGH).

B.2 Force Communication Request may Close a Communication Window

A force communication request (0xFF command) may unintentionally close a communication window instead of opening it. This occurs if the IQS324 receives the force communication request while the RDY is low. The I²C STOP condition at the end of the 0xFF byte triggers the IQS324 to close its communication window, causing the RDY to go back high immediately. This may also happen if the communication window automatically opens during the transmission of the 0xFF byte, as shown in Figure B.1.

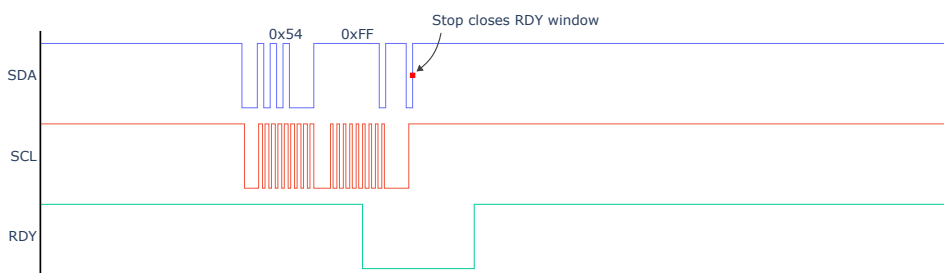

Figure B.1: Force Communication Closing a Communication Window

As a result, the MCU may observe the RDY pin change, and then attempt to communicate with the IC as soon as the force communication transaction is complete. This will cause the IQS324 to respond with the error code 0xEE.

The following protocol can be used to minimise the likelihood of this error condition.



- Step 1: Before sending the 0xFF command, read the state of the RDY pin and verify that it is high (the communication window is closed). If the RDY pin is already low, the communications window is open and can be handled as normal.
- Step 2: If the RDY pin is high, issue the force communication I²C command.
- Step 3: As soon as the I²C transmission of the force communication command has started, wait for the RDY window.
- Step 4: Once the RDY is received, the MCU should wait at least 300 μs, then re-check the state of the RDY pin.
 - (a) If the RDY pin is high, then the window was closed due to the STOP condition. Re-issue the 0xFF command, repeating the above procedure.
 - (b) If the RDY pin is low, the communication window is still open, and normal I²C operations may resume.

Figure B.2 shows an example of this process. The first force communication request occurred simultaneously with a RDY window, and the RDY window was closed due to the STOP condition. The MCU detected the RDY window, waited 300 μs, then checked the RDY pin state. The pin was HIGH, and the force communication request was repeated.

The second request opened the RDY window after some time, and the MCU waited 300 μs again before checking the RDY pin state. The RDY was low, and normal communication could continue.



Figure B.2: Force Communication With RDY Check

It is also recommended to add checks for 0xEE error codes. All status and event flags have reserved upper bits that are always 0. Therefore, the value of those registers can be checked, and considered invalid if they are 0xEE.



C Revision History

Release	Date	Comments
v1.0	September 2024	> Initial document released.
v1.1	March 2025	> Added Known Issues sections regarding force communication. > Added block diagram. > Added Hall Amplifier Gain bits to memory map, register 0x1044. > Updated Hall ATI subsection to include Hall Amplifier Gain. > Added ProxFusion Coarse Gain table with recommended values, register 0x1032. > Added Hall Dividers table with recommended values, register 0x103E. > Updated <i>Minor Version</i> value from '0' to '2'.
v1.2	June 2026	> Updated tape and reel dimensions. > Corrected Digital IO Electrical Specifications. > Updated ESD level for QFN20 package to 4000 V.



Contact Information

	South Africa (Headquarters)	China
Physical Address	1 Bergsig Avenue Paarl 7646 South Africa	Room 501A, Block A T-Share International Centre Taoyuan Road, Nanshan District Shenzhen, Guangdong, PRC
Tel	+27 21 863 0033	+86 755 8303 5294 ext 808
Email	info@azoteq.com	info@azoteq.com

	USA	Taiwan
Physical Address	7000 North Mopac Expressway Suite 200 Austin TX 78731 USA	Xintai 5th Road, Sec. 1 No. 99, 9F-12C Xizhi District 221416 New Taipei City Taiwan
Tel	+1 512 538 1995	+886 932 219 444
Email	info@azoteq.com	info@azoteq.com

*Visit www.azoteq.com
for a list of distributors and worldwide representation.*

Patents as listed on www.azoteq.com/patents-trademarks/ may relate to the device or usage of the device.

Azoteq®, Crystal Driver®, IQ Switch®, ProxSense®, ProxFusion®, LightSense™, SwipeSwitch™, Dycal™, TriggerMax™, WearMax™, and the  logo are trademarks of Azoteq.

The information in this Datasheet is believed to be accurate at the time of publication. Azoteq uses reasonable effort to maintain the information up-to-date and accurate, but does not warrant the accuracy, completeness or reliability of the information contained herein. All content and information are provided on an “as is” basis only, without any representations or warranties, express or implied, of any kind, including representations about the suitability of these products or information for any purpose. Azoteq disclaims all warranties and conditions with regard to these products and information, including but not limited to all implied warranties and conditions of merchantability, fitness for a particular purpose, title and non-infringement of any third party intellectual property rights. Azoteq assumes no liability for any damages or injury arising from any use of the information or the product or caused by, without limitation, failure of performance, error, omission, interruption, defect, delay in operation or transmission, even if Azoteq has been advised of the possibility of such damages. The applications mentioned herein are used solely for the purpose of illustration and Azoteq makes no warranty or representation that such applications will be suitable without further modification, nor recommends the use of its products for application that may present a risk to human life due to malfunction or otherwise. Azoteq products are not authorized for use as critical components in life support devices or systems. No licenses to patents are granted, implicitly, express or implied, by estoppel or otherwise, under any intellectual property rights. In the event that any of the abovementioned limitations or exclusions does not apply, it is agreed that Azoteq’s total liability for all losses, damages and causes of action (in contract, tort (including without limitation, negligence) or otherwise) will not exceed the amount already paid by the customer for the products. Azoteq reserves the right to alter its products, to make corrections, deletions, modifications, enhancements, improvements and other changes to the content and information, its products, programs and services at any time or to move or discontinue any contents, products, programs or services without prior notification. For the most up-to-date information and binding Terms and Conditions please refer to www.azoteq.com.