



IQS243 Datasheet

3 Channel Capacitive Sensor with I²C™ compatible interface and Compensation for Sensitivity Reducing Objects

Unparalleled Features

- Sub 3uA current consumption
- Automatic tuning for optimal operation in various environments

The IQS243 ProxSense® IC is a fully integrated 3 channel capacitive contact and proximity sensor with market leading sensitivity and automatic tuning to the sense electrode. The IQS243 provides a cost effective implementation in a small outline package. The device is ready for use in a large range of applications while the I²C™ compatible interface provides full control to a host.

Main Features

- 3 Channel input device
- Proximity & Touch on each channel
- I²C™ Compatible data output
- ATI: Automatic tuning to optimum sensitivity
- Supply Voltage 1.8V (abs min) to 3.6V (abs max)
- Multiple Power Modes
- Internal voltage regulator and reference capacitor
- Large proximity detection range
- Automatic drift compensation
- Development tools available (IQS243 GUI and USB dongles)
- Small outline MSOP–10

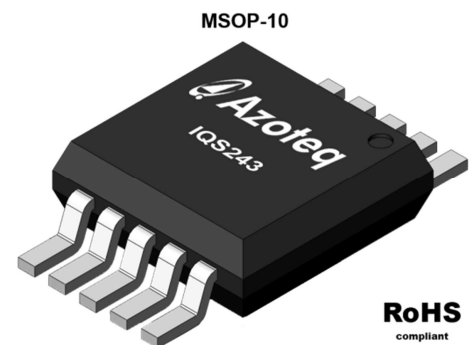

Applications

- White goods and appliances
- Office equipment, toys, sanitary ware
- Proximity detection that enables backlighting activation (Patented)
- Wake-up from standby applications
- Replacement for electromechanical switches
- GUI trigger and GUI control proximity detection

Available options

T _A	MSOP-10
-40°C to 85°C	IQS243



Functional Overview

1 Introduction

The IQS243 is a three channel capacitive proximity and touch sensor featuring an internal voltage regulator and reference capacitor (Cs).

The device has three dedicated input pins for the connection of the sense electrodes. Three output pins are used for serial data communication through the I²C™ compatible protocol, including an optional RDY pin.

The device automatically tracks slow varying environmental changes via various filters, detect noise and has an Auto Tuning Implementation (ATI) to tune the device for optimal sensitivity.

1.1 Applicability

All specifications, except where specifically mentioned otherwise, provided by this datasheet are applicable to the following ranges:

- Temperature -40°C to +85°C
- Supply voltage (VDDHI) 1.8V to 3.6V

1.2 Pin-outs

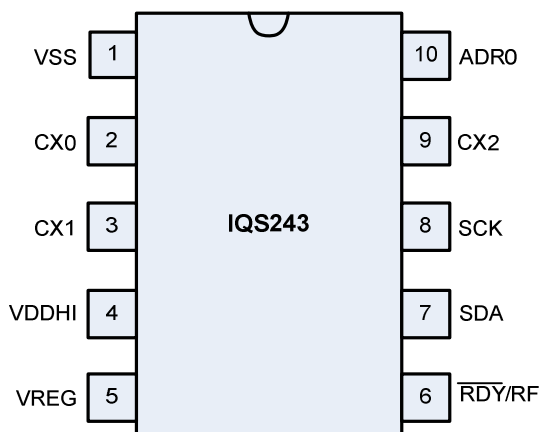

Figure 1.1 IQS243 Pin layout.

Table 1.1 IQS243 Pin-outs.

Pin	IQS243 MSOP 10	Function
1	VSS	Ground
4	VDDHI	Power Input
5	VREG	Regulator Pin
2	CX0	Sense Electrode
3	CX1	Sense Electrode
9	CX2	Sense Electrode
10	ADR0	I ² C™ Sub Address Selection
6	RDY/RF	I ² C™ Ready or RF input pin
7	SDA	I ² C™ Data
8	SCK	I ² C™ Clock

2 Analogue Functionality

The analogue circuitry measures the capacitance of the sense electrodes attached to the Cx pins through a charge transfer process that is periodically initiated by the digital circuitry. The capacitance measurement circuitry makes use of an internal reference capacitor Cs and voltage reference (VREG).

The measuring process is referred to as a conversion and consists of the discharging of Cs and Cx capacitors, the charging of Cx and then a series of charge transfers from Cx to Cs until a trip voltage is reached. The number of charge transfers required to reach the trip voltage is referred to as the Current Sample (CS).

The analogue circuitry further provides functionality for:

- Power On Reset (POR) detection.
- Brown Out Detection (BOD).

3 Digital Functionality

The digital processing functionality is responsible for:

- Management of BOD and WDT events.

- Initiation of conversions at the selected rate.
- Processing of CS and execution of algorithms.
- Monitoring and automatic execution of the ATI algorithm.
- Signal processing and digital filtering.
- Detection of PROX and TOUCH events.
- Managing outputs of the device.
- Managing serial communications.

Detailed Description

4 Reference Design

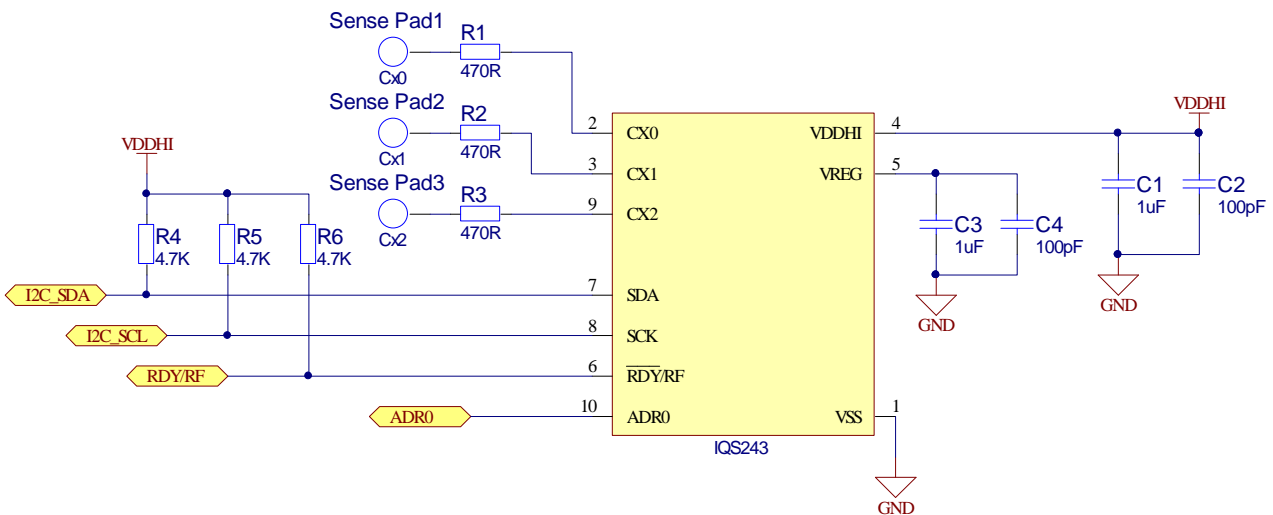

Figure 4.1 Reference Design.

- Use C2 and C4 for added RF noise immunity.
- Place C1-C4 as close as possible to IC, connected to good GND.
- R4, R5 and R6 used as pull up resistors for I²C™ protocol (4.7k to 10k typical).
- RDY Pin and R6 required for Event Mode.
- Refer to Application Note (AZD008) on key pad design.

5 High Sensitivity

Through patented design and advanced signal processing, the device is able to provide extremely high sensitivity to detect proximity. This enables designs that can detect proximities at a much greater range than other

capacitive sensors. When the device is used in the presence of noise or floating metal that lower the sensitivity, a reduced proximity threshold is proposed to ensure reliable functioning of the sensor. The high sensitivity allows the device to sense accurately through overlays with low dielectric constant materials such as wood or even air-gaps.



Please refer to the Application Note Section on the Azoteq website for more design tips and other application dependent recommendations.

$$T_{TH} = < LTA - CS$$

With lower average CS (therefore lower LTA) values the touch threshold will be lower and vice versa. Individual touch threshold can be set for each channel.

6 Adjustable Proximity Threshold

The proximity threshold is selected by the designer to obtain the desired proximity sensitivity and is selectable between 1 (most sensitive) to 254 (least sensitive). The IQS243 has a default proximity threshold (P_{TH}) of 4 for all channels. Proximity thresholds for the sense electrodes are individually adjustable between the specified limits.

A proximity event is identified when for at least 6 consecutive samples the following equation holds:

$$P_{TH} = < LTA - CS$$

Where LTA is the Long Term Average

7 Adjustable Touch Thresholds

The touch threshold is selected by the designer to obtain the desired touch sensitivity and is selectable between 1/255 (most sensitive) to 254/255 (least sensitive). The IQS243 has a default touch threshold (T_{TH}) of 32/255 (for all 3 channels). The touch threshold is expressed as a fraction of the LTA as follows:

$$T_{TH} = \text{Selected Touch Threshold} \times LTA$$

Where LTA is the Long Term Average

The touch event is triggered based on T_{TH} , CS and LTA. A touch event is identified when for at least 2 consecutive samples the following equation holds:

8 Charge Transfers

The IQS243 samples in 4 timeslots. The charge sequence is shown in Figure 8.1, where CH0 is the Prox channel, which charges before each of the 3 input channels. CH0 is realised by connecting all three touch electrodes with internal switches. Therefore: CH0 is a distributed electrode formed by the 3 touch electrodes.

Proximity can be detected by the distributed electrode ($CRX0 + CRX1 + CRX2$) AND each individual sense electrode ($CRX0$, $CRX1$ and $CRX2$).

9 I2C Communication

The IQS243 device interfaces to a master controller via a 2 wire serial interface bus that is I²C™ compatible. An optional RDY pin is available to indicate the communication window (required for Event Mode).

The IQS243 has four available sub addresses, 44H (default) to 47H that is selected upon purchase of the IC. The ADR0 pin can also be pulled low to increase the I2C address by one decimal value (for example from 44H to 45H).

The maximum I²C™ compatible communication speed for the IQS243 is 400kbit/s.

Please refer to the IQS243 Communications Interface and Sample Code Document for further details.

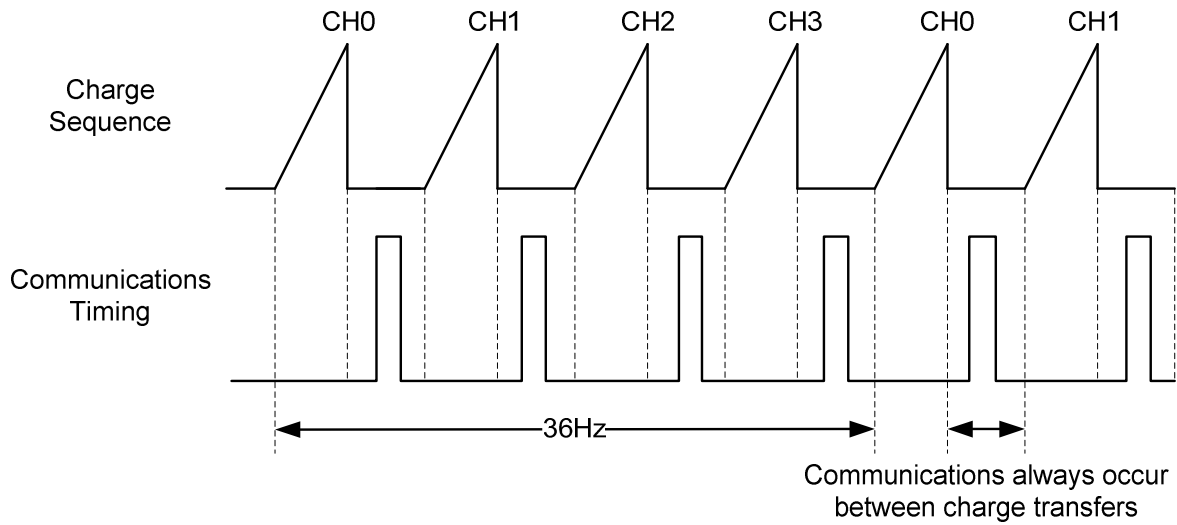

Figure 8.1 Charging and communications sequence for the IQS243.

9.1 Memory Mapping

Address	Size(Bytes)	Access
00h-0Fh	16	R/W, R
10h-30h	32	R/W
31h-34h	4	R/W, R
35h-38h	4	R/W, R

Device Information	R/W
	R

Device Specific Data	R/W
----------------------	-----

Proximity Status Bytes	R/W
	R

Touch Status Bytes	R/W
	R



39h-3Ch

4

Halt Bytes	R/W
	R

3Dh-41h

4

Active Bytes (indicate cycle)	R/W
	R

42h-82h

64

Current Samples	R/W
	R

83h-C3h

64

LTAs	R/W
	R

C4h-FDh

64

Device Settings	R/W
	W



9.1.1 Device Information

Information regarding the device type and version is recorded here. Any other information specific to the device version can be stored here. Each Azoteq ROM has a unique Product- and Version number.

00H	Product Number (PROD_NUM)								R/W	
	Bit	7	6	5	4	3	2	1	0	
		36D								R

01H	Version Number (VERSION_NUM)								R/W	
	Bit	7	6	5	4	3	2	1	0	
		01D								R

9.1.2 Device Specific Data

10H	System Status Flags (SYSFLAGS)								R/W	
	Bit	7	6	5	4	3	2	1	0	
		System use	System use	System use	System use	System use	ATI Busy	RF Noise	Zoom	R

ATI BUSY	Indicates whether the device is performing an ATI ‘0’: ATI not Busy ‘1’: ATI Busy
RF Noise	Indicates whether RF noise is detected “0”: Not Detected “1”: Detected
Zoom	Indicates whether the device is in Zoom mode “0”: Not in Zoom “1”: In Zoom

9.1.3 Proximity Status Bytes



The proximity status of all the channels on the device are shown here. If a byte is set it indicates a proximity condition on the specified channel.

31H	Proximity (PROX_STAT)								R/W
	Bit	7	6	5	4	3	2	1	0
	System use	System use	System use	System use	CH3	CH2	CH1	CH0	R

The SHOW_RESET byte is automatically set whenever the device is reset. Setting the Ack Reset byte in the Proxsense Module Settings 2 register clears the SHOW_RESET byte.

32H	Show Reset (SHOW_RESET)								R/W
	Bit	7	6	5	4	3	2	1	0
	SHOW_RESET	System use	System use	System use	System use	System use	System use	System use	R

9.1.4 Touch Status Bytes

The touch status of all the channels on the device are shown here. If a byte is set it indicates a touch condition on the specified channel.

35H	Touch Status 0 (TOUCH_STAT0)								R/W
	Bit	7	6	5	4	3	2	1	0
	System use	System use	System use	System use	CH3	CH2	CH1	System use	R

36H	Touch Status 1 (TOUCH_STAT1)								R/W
	Bit	7	6	5	4	3	2	1	0
	System use	System use	System use	System use	System use	System use	System use	System use	R



9.1.5 Halt Bytes

The filter halt status of all the channels on the device are shown here. If a byte is set it indicates that the filters have been halted on the specified channel.

39H	Halt 0 (HALT_STAT0)								R/W	
	Bit	7	6	5	4	3	2	1	0	
		System use	System use	System use	System use	CH3	CH2	CH1	CH0	R

3AH	Halt 1 (HALT_STAT1)								R/W	
	Bit	7	6	5	4	3	2	1	0	
		System use	System use	System use	System use	System use	System use	System use	System use	R

9.1.6 Channel Number

The decimal number in the Active Channel register indicates the active channel.

3DH	Active Channel (ACT_CHAN)								R/W	
	Bit	7	6	5	4	3	2	1	0	
		Decimal Number indicating active channel (CH0 – CH3)								R

9.1.7 Current Samples

The Current Samples stored in this register are from the current cycle only as indicated in the Active Channel register.

42H	Current Sample High (CUR_SAM_HI)								R/W	
	Bit	7	6	5	4	3	2	1	0	
		HIGH byte								R

43H	Current Sample Low (CUR_SAM_LO)								R/W	
	Bit	7	6	5	4	3	2	1	0	
		LOW byte								R



9.1.8 Long-Term Averages

The Long-Term Averages stored in this register are from the current cycle only.

83H	Long-Term Average High (LTA_HI)								R/W	
	Bit	7	6	5	4	3	2	1	0	
		HIGH byte								R

84H	Long-Term Average Low (LTA_LO)								R/W	
	Bit	7	6	5	4	3	2	1	0	
		LOW byte								R

9.1.9 Device Settings

Target Count 0 and 1 sets the target CS value for the respective channels. If data is written to one of these channels and the LTA is out of range a re-ATI event will occur, unless a touch condition is active on the channel where the re-ATI will wait until the touch condition is lifted. The default target CS for CH0 with a register value Target Count CH0 = 128 then becomes $128 \times 8 = 1024$. The device will re-ATI when the LTA drifts out of the Target ± 128 (default) range.

C4H	Target Count CH0 (TARGET_CNT0)								R/W	
	Bit	7	6	5	4	3	2	1	0	
		Target Count Value (x8)								R/W
	Default: 128 Decimal (re-ATI boundary)									

C5H	Target Count (TARGET_CNT1)								R/W	
	Bit	7	6	5	4	3	2	1	0	
		Target Count Value (x8) for CH1 – CH3								R/W
	Default: 128 Decimal (re-ATI boundary)								R/W	



The compensation for each channel can be set by writing the appropriate value to the corresponding channels Compensation Register. The Compensation directly influences the sensitivity of a Channel and will trigger a re-ATI when the LTA of the respective channels are out of range.

C6H	Channel 0 Compensation Setting (CH0_COMP)								R/W	
	Bit	7	6	5	4	3	2	1	0	
		Compensation 0 <5:0>							R/W	

C7H	Channel 1 Compensation Setting (CH1_COMP)								R/W	
	Bit	7	6	5	4	3	2	1	0	
		Compensation 1 <5:0>							R/W	

C8H	Channel 2 Compensation Setting (CH2_COMP)								R/W	
	Bit	7	6	5	4	3	2	1	0	
		Compensation 2 <5:0>							R/W	

C9H	Channel 3 Compensation Setting (CH3_COMP)								R/W	
	Bit	7	6	5	4	3	2	1	0	
		Compensation 3 <5:0>							R/W	

CAH	System Use								R/W	
	Bit	7	6	5	4	3	2	1	0	
		System Use							R/W	

CBH	System Use								R/W	
	Bit	7	6	5	4	3	2	1	0	
		System Use							R/W	



CCH

	System Use								R/W
Bit	7	6	5	4	3	2	1	0	
	System Use								R/W

CDH

	System Use								R/W
Bit	7	6	5	4	3	2	1	0	
	System Use								R/W

CEH

	System Use								R/W
Bit	7	6	5	4	3	2	1	0	
	System Use								R/W

CFH

	System Use								R/W
Bit	7	6	5	4	3	2	1	0	
	System Use								R/W

The Multiplier Setting register for each Channel sets the gain values which determine the sensitivity and compensation to reach the ATI routine target. The Table below provides a description of the bits that can be set in the CH0 – CH3 Multiplier Setting registers. By writing to the Multiplier Settings of a channel, the individual channel that is active in that specific time slot (indicated in the Channel Sequence 0 and 1 registers) will undergo a re-ATI event if the new multiplier settings results in the LTA being out of range



Base7:6	The base value influences the overall sensitivity of the channel and establishes a base count from where the ATI algorithm starts executing. The following options are available: "00" – 200 "01" – 50 "10" – 100 "11" – 250
Mul5:Mul4	Sensitivity Multiplier
Mul3:0	Compensation Multiplier

D0H

Channel 0 Multiplier Setting (MULT_CH0)									R/W
Bit	7	6	5	4	3	2	1	0	
	Base1	Base0	Mul5	Mul4	Mul3	Mul2	Mul1	Mul0	R/W

D1H

Channel 1 Multiplier Setting (MULT_CH1)									R/W
Bit	7	6	5	4	3	2	1	0	
	Base1	Base0	Mul5	Mul4	Mul3	Mul2	Mul1	Mul0	R/W

D2H

Channel 2 Multiplier Setting (MULT_CH2)									R/W
Bit	7	6	5	4	3	2	1	0	
	Base1	Base0	Mul5	Mul4	Mul3	Mul2	Mul1	Mul0	R/W

D3H

Channel 3 Multiplier Setting (MULT_CH3)									R/W
Bit	7	6	5	4	3	2	1	0	
	Base1	Base0	Mul5	Mul4	Mul3	Mul2	Mul1	Mul0	R/W



D4H	System Use									R/W
	Bit	7	6	5	4	3	2	1	0	
		System Use	System Use	System Use	System Use	System Use	System Use	System Use	System Use	R/W

D5H	System Use									R/W
	Bit	7	6	5	4	3	2	1	0	
		System Use	System Use	System Use	System Use	System Use	System Use	System Use	System Use	R/W

D6H	System Use									R/W
	Bit	7	6	5	4	3	2	1	0	
		System Use	System Use	System Use	System Use	System Use	System Use	System Use	System Use	R/W

D7H	System Use									R/W
	Bit	7	6	5	4	3	2	1	0	
		System Use	System Use	System Use	System Use	System Use	System Use	System Use	System Use	R/W

D8H	System Use									R/W
	Bit	7	6	5	4	3	2	1	0	
		System Use	System Use	System Use	System Use	System Use	System Use	System Use	System Use	R/W

D9H	System Use									R/W
	Bit	7	6	5	4	3	2	1	0	
		System Use	System Use	System Use	System Use	System Use	System Use	System Use	System Use	R/W



The proximity sensitivity settings of each respective channel sets the CS threshold for a proximity event on the specified channel (refer to Section 6). A custom value between 1 and 254 can be selected by setting bits PT_7 to PT_0.



DAH

Proximity Sensitivity Settings CH0 (PROX_TH_CH0)										R/W
Bit	7	6	5	4	3	2	1	0		
	PT_7	PT_6	PT_5	PT_4	PT_3	PT_2	PT_1	PT_0	R/W	
	Custom value between 1 and 254									
Default	0	0	0	0	0	1	0	0		

DBH

Proximity Sensitivity Settings CH1 (PROX_TH_CH1)										R/W
Bit	7	6	5	4	3	2	1	0		
	PT_7	PT_6	PT_5	PT_4	PT_3	PT_2	PT_1	PT_0	R/W	
	Custom value between 1 and 254									
Default	0	0	0	0	0	1	0	0		

DCH

Proximity Sensitivity Settings CH 2 (PROX_TH_CH2)										R/W
Bit	7	6	5	4	3	2	1	0		
	PT_7	PT_6	PT_5	PT_4	PT_3	PT_2	PT_1	PT_0	R/W	
	Custom value between 1 and 254									
Default	0	0	0	0	0	1	0	0		

DDH

Proximity Sensitivity Settings CH3 (PROX_TH_CH3)										R/W
Bit	7	6	5	4	3	2	1	0		
	PT_7	PT_6	PT_5	PT_4	PT_3	PT_2	PT_1	PT_0	R/W	
	Custom value between 1 and 254									
Default	0	0	0	0	0	1	0	0		



DEH

	System Use								R/W
Bit	7	6	5	4	3	2	1	0	
	System Use	System Use	System Use	System Use	System Use	System Use	System Use	System Use	R/W

The touch sensitivity setting of each respective channel sets the CS threshold for a touch event on the specified channel. A custom value between 1 and 254 can be selected by setting bits.

DFH

	Touch Sensitivity Settings CH1 (TOUCH_TH_CH1)								R/W
Bit	7	6	5	4	3	2	1	0	
	TT_7	TT_6	TT_5	TT_4	TT_3	TT_2	TT_1	TT_0	R/W
	Custom value between 1 and 254, used as value/255								R/W
Default	32/255								

E0H

	Touch Sensitivity Settings CH2 (TOUCH_TH_CH2)								R/W
Bit	7	6	5	4	3	2	1	0	
	TT_7	TT_6	TT_5	TT_4	TT_3	TT_2	TT_1	TT_0	R/W
	Custom value between 1 and 254, used as value/255								R/W
Default	32/255								

E1H

	Touch Sensitivity Settings CH3 (TOUCH_TH_CH3)								R/W
Bit	7	6	5	4	3	2	1	0	
	TT_7	TT_6	TT_5	TT_4	TT_3	TT_2	TT_1	TT_0	R/W
	Custom value between 1 and 254, used as value/255								R/W
Default	32/255								



E2H

	System Use								R/W
Bit	7	6	5	4	3	2	1	0	
	System Use	System Use	System Use	System Use	System Use	System Use	System Use	System Use	R/W

E3H

	System Use								R/W
Bit	7	6	5	4	3	2	1	0	
	System Use	System Use	System Use	System Use	System Use	System Use	System Use	System Use	R/W

E4H

	System Use								R/W
Bit	7	6	5	4	3	2	1	0	
	System Use	System Use	System Use	System Use	System Use	System Use	System Use	System Use	R/W

E5H

	System Use								R/W
Bit	7	6	5	4	3	2	1	0	
	System Use	System Use	System Use	System Use	System Use	System Use	System Use	System Use	R/W

E6H

	System Use								R/W
Bit	7	6	5	4	3	2	1	0	
	System Use	System Use	System Use	System Use	System Use	System Use	System Use	System Use	R/W

E7H

	System Use								R/W
Bit	7	6	5	4	3	2	1	0	
	System Use	System Use	System Use	System Use	System Use	System Use	System Use	System Use	R/W



E8H

ProxSense Module Settings 0 (PROX_SETTINGS0)									
Bit	7	6	5	4	3	2	1	0	R/W
	ATI Off	Partial ATI	ATI Current Channel	Redo_ATI	Reseed	CS Size	System Use	System Use	R/W
Default	0	0	0	0	0	0	1	0	

ATI Off	If this bit is set, the ATI routine will be disabled ‘0’: ATI On ‘1’: ATI Off
Partial ATI	Uses the Multipliers to determine the sensitivity and compensation to reach the ATI target, instead of the full ATI routine “0”: Disabled “1”: Enabled
ATI Current Channel	Performs a re-ATI on the current channel, as indicated by the Sequence register 3DH
Redo ATI	Forces the ATI routine to run when a ‘1’ is written into this bit position. ATI Off in address E8H bit 7 takes priority
Reseed	All channels are reseeded when a ‘1’ is written into this bit position. The LTA’s are set to 8 counts below the current samples
CS Size	The internal charge capacitor is normally 29.9pF, if this bit is set the charge capacitor becomes 59.8pF

E9H

ProxSense Module Settings 1 (PROX_SETTINGS1)									
Bit	7	6	5	4	3	2	1	0	R/W
	System Use	CRX Float	Turbo Mode	Halt Charge/ULP	Noise Detect On	System Use	System Use	System Use	R/W
Default	0	0	0	0	0	0	0	0	



CRX Float	During conversions the inactive channels are grounded in order to minimize noise coupling. If this bit is set the receiver electrodes will float when inactive
Turbo mode	If this bit is set, conversions are performed as fast as processing and communication allows, thereby maximizing detection speed
Halt Charge/ULP	Set this bit to stop all conversions. The device will now draw the minimum amount of power
Noise Detect On	Enables the noise detection '0': Disabled '1': Enabled

EAH

ProxSense Module Settings 2 (PROX_SETTINGS2)									R/W
Bit	7	6	5	4	3	2	1	0	
	Ack Reset	WDT Off	Force Halt	AC Filter Disable	Timeout Disable	Event Mode	Halt1	Halt0	R/W
Default	0	0	0	0	0	0	0	0	

Note: The WDT will RESET the IC if there is a break in communication for longer than 13ms after the master initialised communication. The Timeout Disable feature will exit the communication window if comms is not initialised within 20ms by the master controller.



Ack Reset	Clears the reset bit 0 = Default 1 = Clears SHOW_RESET
WDT Off	Disable the watchdog timer 0 = Enabled 1 = Disabled
Force Halt	Forces the Long Term Average of all channels to stop being calculated '0': LTA updates normally '1': LTA is halted
AC filter Disable	Set the AC filter. Disabling the AC filter will enable a faster response time 0 = Enabled 1 = Disabled
Timeout Disable	If this bit is set, a timeout will be allowed on the communication 0 = Disabled 1 = Enabled
Event Mode	Sets Event driven I ² C communication 0 = Event Mode 1 = Streaming Mode
Halt1:Halt0	Sets the Halt time for the LTA (time before recalibration) 00 = 20 Seconds 01 = 40 Seconds 10 = Never 11 = Permanent



EBH

		ProxSense Module Settings 3 (PROX_SETTINGS3)							R/W
Bit	7	6	5	4	3	2	1	0	
	Beta1 CH0	Beta0 CH0	Beta1	Beta0	Alternative ATI Enable	System Use	Charge Xfer Speed 1	Charge Xfer Speed 0	R/W
Default	0	1	0	1	0	n/a	0	1	

Note: Beta values are constants used in the calculation of the LTA filter. A smaller Beta value will cause the LTA to track the CS faster. This means, there is less chance of a false proximity event with environmental changes such as temperature change, but also means more chance of reduced proximity detection distance when the user approaches slowly.

Beta1:0 CH0	Beta CH0 "00": 1/32 "01": 1/64 "10": 1/128 "11": 1/256
Beta1:0	Beta (CH1 to CH3) "00": 1/32 "01": 1/64 "10": 1/128 "11": 1/256
Alternative ATI Enable	Set the alternative ATI function "0" = Disable "1" = Enable
Charge Xfer Speed0:1	Charge Transfer Speed "00": 1MHz "01": 500kHz "10": 250kHz (Period will be too long and negatively impact times) "11": 125kHz (Period will be too long and negatively impact times)



ECH

	Channel Enable for CH0 – CH3 (CHAN_ENABLE)								R/W
Bit	7	6	5	4	3	2	1	0	
	System use	System Use	System Use	System Use	CH3	CH2	CH1	CH0	R/W

CH3:CH0	Software enable or disable of channels: 0 = Channel Disabled 1 = Channel Enabled
---------	--

EDH

	System Use								R/W
Bit	7	6	5	4	3	2	1	0	
	System Use	System Use	System Use	System Use	System Use	System Use	System Use	System Use	R/W

EEH

	Low Power Settings (LOW_POWER)								R/W
Bit	7	6	5	4	3	2	1	0	
	Custom value between 1 and 256 – value x 16ms = LP period								R/W
Default	Normal power default (00H). See Note below.								R/W

NOTE: While in any power mode the device will zoom to Boost Power (BP) mode whenever a current sample (CS) indicates a possible proximity or touch event. This improves the response time. The device will remain in BP for t_{zoom} seconds (~5s) and then return to the selected power mode. The Zoom function allows reliable detection of events with current samples being produced at the BP rate. The t_{zoom} timer will be restarted with every undebounced proximity (or larger) event.

F0H

	Default Comms Pointer (DFLT_COMMS_PTR)								R/W
Bit	7	6	5	4	3	2	1	0	
Default	10H								W



10 Auto Tuning Implementation (ATI)

ATI is a sophisticated patented technology implemented on the second generation ProxSense® devices that optimises the performance of the sensor in a wide range of applications and environmental conditions (refer to application note AZD0027 - Auto Tuning Implementation).

ATI is a combination of semiconductor hardware and signal processing algorithms.

Internal circuitry is adjusted according to two parameters, the ATI multiplier and the ATI compensation. The ATI multiplier can be viewed as a course adjustment and the ATI compensation as a fine adjustment.

An algorithm will adjust the ATI parameters to optimise the sensing electrode's connection to the device.

The algorithm 'hunts' for optimal settings at power-up and whenever the count value is outside pre-determined boundaries.

The adjustment of the ATI parameters will result in variations in the count value and sensitivity. Sensitivity can be observed as the change in counts as the result of a fixed change in sensed capacitance. The ATI parameters have been chosen to provide significant overlap. It may therefore be possible to select various combinations of ATI multiplier and ATI compensation settings to obtain the same current sample. The sensitivity of the various options may however be slightly different for the same count.

While the ATI algorithm is executed, the condition is indicated in the streaming data and proximity and touch events are briefly disabled. The device will only enter re-calibration when relatively large shifts in the count value are detected.

The ATI function aims to maintain a constant count value, regardless of the capacitance of the sense electrode (within the range of the device).

The effects of ATI on the application are the following:

- Automatic adjustment of the device configuration and processing parameters for a wide range of PCB and application designs to maintain an optimal configuration for proximity and touch detection.
- Automatic tuning of the sense electrode at start-up to optimise the sensitivity of the application.
- Automatic re-tuning when the device detects changes in the sensing electrodes' capacitance to accommodate a large range of changes in the environment of the application that influences the sensing electrodes.
- Re-tuning only occurs during device operation when a relatively large sensitivity reduction is detected. This is to ensure smooth operation of the device during operation.
- Re-tuning may temporarily influences the normal functioning of the device, but in most instances the effect will be hardly noticeable.
- Shortly after the completion of the re-tuning process the sensitivity of Proximity detection may be reduced slightly for a few seconds as internal filters stabilises.

ATI can be implemented so effectively due to:

- Excellent system Signal to Noise Ratio (SNR).
- Effective digital signal processing to remove AC and other noise.
- The very stable core of the devices.
- The built in capability to accommodate a large range of sensing electrode capacitances.



10.1 Partial ATI

Partial ATI allows the designer to manually adjust the gain of the various channels to fit the specific needs of the application.

By default (Address: E8H bit 6 = 0) the ATI routine sets the required base value of the touch channels to 250 counts. The required base value for the proximity channel is specified through I²C commands in address D0H bits [7:6] with the default being 200. The base value for each individual channel can be set via bits [7:6] on the address range D0H to D9H.

Alternatively, the user can set the multiplier bits [5:0] in addresses D0H through D9H which would determine the sensitivity, and

compensation (scaled) to reach the ATI target.

With the base value set, the Partial ATI routine would use a convergence technique with a fixed amount of steps to reach its aimed target.

10.2 Alternative ATI

The Alternative ATI implementation ensures that the base and multiplier values are identical for all the channels and adjusts only the compensation in order to achieve the desired count value. The Alternative ATI can be enabled by setting bit [3] of address EBH.



11 Specifications

11.1 Absolute Maximum Specifications

The following absolute maximum parameters are specified for the device:

Exceeding these maximum specifications may cause damage to the device.

<input type="checkbox"/> Operating temperature	-40°C to 85°C
<input type="checkbox"/> Supply Voltage (VDDHI – VSS)	3.6V
<input type="checkbox"/> Maximum pin voltage exceed VDDHI max)	VDDHI + 0.5V (may not
<input type="checkbox"/> Maximum continuous current (for specific Pins)	10mA
<input type="checkbox"/> Minimum pin voltage	VSS - 0.5V
<input type="checkbox"/> Minimum power-on slope	100V/s
<input type="checkbox"/> ESD protection	±4kV Human body model
<input type="checkbox"/> Package Moisture Sensitivity Level (MSL)	1

Table 11.1 IQS243 General Operating Conditions¹

DESCRIPTION	Conditions	PARAMETER	MIN	TYP	MAX	UNIT
Supply voltage	-	V _{DDHI}	1.8	3.3V	3.6	V
Internal regulator output	$1.8 \leq V_{DDHI} \leq 3.6$	V _{REG}	1.62	1.7	1.79	V
Boost Operating Power	VDDHI: 3.3V LOW_POWER register:0 Turbo Mode: ON	I _{IQS243_BP}	-	152	-	μA
Normal Operating Power	VDDHI: 3.3V LOW_POWER register: 0 Turbo Mode: OFF	I _{IQS243_NP}	-	148	-	μA
LP Mode 1*	VDDHI: 3.3V LOW_POWER register: 4	I _{IQS243_LP1}	-	45	-	μA
LP Mode 2*	VDDHI: 3.3V LOW_POWER register: 8	I _{IQS243_LP2}	-	20.7	-	μA
LP Mode 3*	VDDHI: 3.3V LOW_POWER register: 16	I _{IQS243_BP3}	-	10.6	-	μA
LP Mode 4*	VDDHI: 3.3V LOW_POWER register:32	I _{IQS243_LP4}	-	5.6	-	μA

¹ Operating current shown in this datasheet, does not include power dissipation through I²C pull up resistors.



DESCRIPTION	Conditions	PARAMETER	MIN	TYP	MAX	UNIT
LP Mode 5*	VDDHI: 3.3V LOW_POWER register: 64	I _{IQS243_LP5}	-	3.5	-	μA
LP Mode 6*	VDDHI: 3.3V LOW_POWER register: 128	I _{IQS243_LP6}	-	2.5	-	μA

*LP interval period = Low power value x 16ms

Table 11.2 Start-up and shut-down slope Characteristics

DESCRIPTION	Conditions	PARAMETER	MIN	MAX	UNIT
Power On Reset	V _{DDHI} Slope ≥ 100V/s @25°C	POR	1.2	1.6	V
Brown Out Detect	V _{DDHI} Slope ≥ 100V/s @25°C	BOD	1.15	1.6	V

Table 11.3 Initial Touch Times

DESCRIPTION	PARAMETER	Typical	Unit
BP ¹	Response time	13	ms
NP	Response time	45	ms
LP6	Response time	2000	ms

¹ Communication and charge frequency to comply with sample rate as reported earlier in this datasheet.



12 Mechanical Dimensions

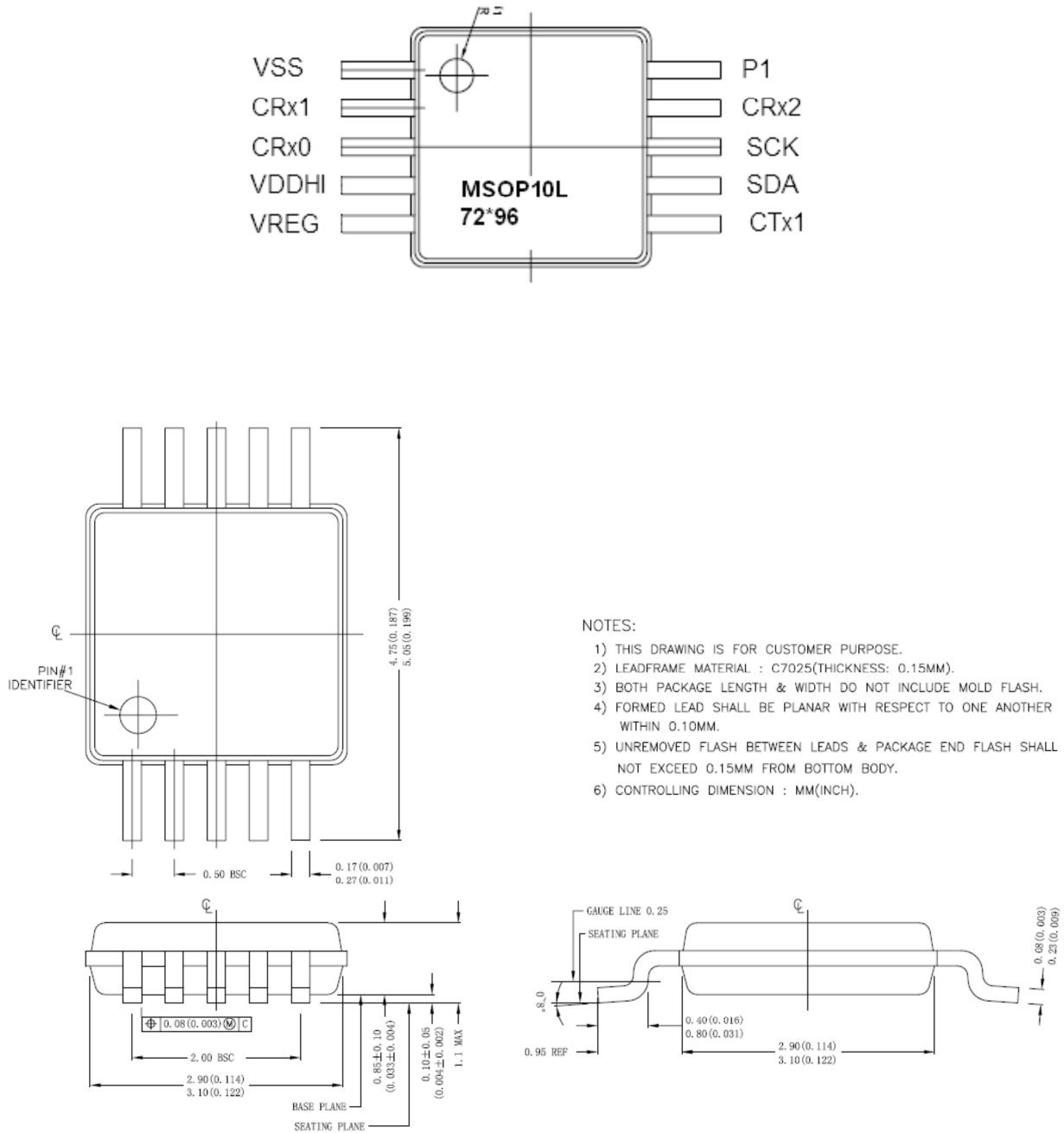
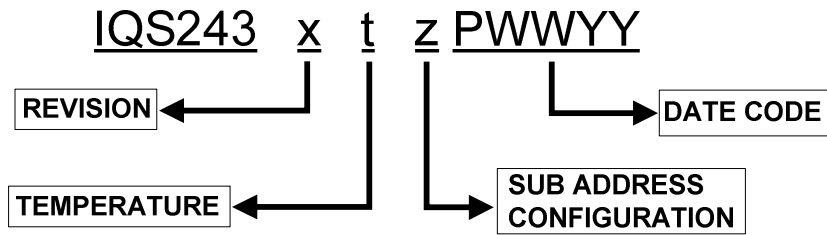

Figure 12.1 MSOP-10 Package Dimensions



13 Device Marking



REVISION	x	=	IC Revision Number
TEMPERATURE RANGE	t	=	I -40°C to 85°C (Industrial) C 0°C to 70°C (Commercial)
IC CONFIGURATION	z	=	Sub Address Configuration (Hexadecimal) 0 = 44H 1 = 45H 2 = 46H 3 = 47H
DATE CODE	P	=	Package House
	WW	=	Week
	YY	=	Year

14 Ordering Information

Order quantities will be subject to multiples of a full reel. Contact the official distributor for sample quantities. A list of the distributors can be found under the “Distributors” section of www.azoteq.com.

For large orders, Azoteq can provide pre-configured devices.

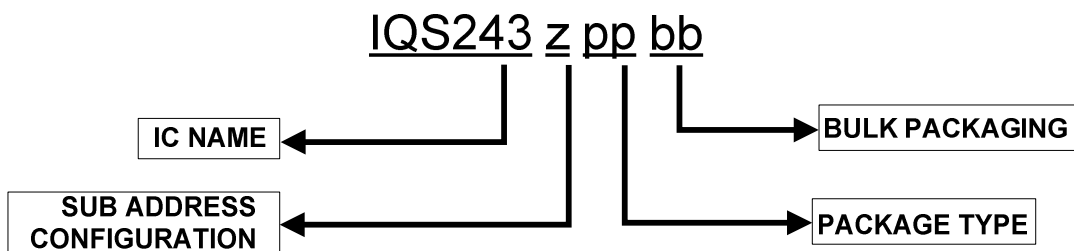

IC NAME	IQS243	=	IQS243
CONFIGURATION	z	=	Sub Address Configuration (hexadecimal)
PACKAGE TYPE	MS	=	MSOP-10
BULK PACKAGING	RR	=	Reel (4000pcs/reel)
	TT	=	Tube (96pcs/tube) Special order only

**Appendix A. Contact information**

	USA	Asia	South Africa
Physical Address	6507 Jester Blvd Bldg 5, suite 510G Austin TX 78750 USA	Rm2125, Glittery City Shennan Rd Futian District Shenzhen, 518033 China	109 Main Street Paarl 7646 South Africa
Postal Address	6507 Jester Blvd Bldg 5, suite 510G Austin TX 78750 USA	Rm2125, Glittery City Shennan Rd Futian District Shenzhen, 518033 China	PO Box 3534 Paarl 7620 South Africa
Tel	+1 512 538 1995	+86 755 8303 5294 ext 808	+27 21 863 0033
Fax	+1 512 672 8442		+27 21 863 1512
Email	kobusm@azoteq.com	linayu@azoteq.com.cn	info@azoteq.com

Appendix B. Please visit www.azoteq.com for a list of distributors and worldwide representation.

The following patents relate to the device or usage of the device: US 6,249,089 B1; US 6,621,225 B2; US 6,650,066 B2; US 6,952,084 B2; US 6,984,900 B1; US 7,084,526 B2; US 7,084,531 B2; US 7,265,494 B2; US 7,291,940 B2; US 7,329,970 B2; US 7,336,037 B2; US 7,443,101 B2; US 7,466,040 B2 ; US 7,498,749 B2; US 7,528,508 B2; US 7,755,219 B2; US 7,772,781 B2; US 7,781,980 B2; US 7,915,765 B2; US 7,994,726 B2; US 8,035,623 B2; US RE43,606 E; US 8,288,952 B2; US 8,395,395 B2; US 8,531,120 B2; US 8,659,306 B2; US 8,823,273 B2 B2; EP 1 120 018 B2; EP 1 206 168 B1; EP 1 308 913 B1; EP 1 530 178 A1; EP 2 351 220 B1; EP 2 559 164 B1; CN 1330853; CN 1783573; AUS 761094; HK 104 1401

IQ Switch[®], SwipeSwitch[™], ProxSense[®], LightSense[™], AirButton[™] and the logo are trademarks of Azoteq.

The information in this Datasheet is believed to be accurate at the time of publication. Azoteq uses reasonable effort to maintain the information up-to-date and accurate, but does not warrant the accuracy, completeness or reliability of the information contained herein. All content and information are provided on an "as is" basis only, without any representations or warranties, express or implied, of any kind, including representations about the suitability of these products or information for any purpose. Azoteq disclaims all warranties and conditions with regard to these products and information, including but not limited to all implied warranties and conditions of merchantability, fitness for a particular purpose, title and non-infringement of any third party intellectual property rights. Azoteq assumes no liability for any damages or injury arising from any use of the information or the product or caused by, without limitation, failure of performance, error, omission, interruption, defect, delay in operation or transmission, even if Azoteq has been advised of the possibility of such damages. The applications mentioned herein are used solely for the purpose of illustration and Azoteq makes no warranty or representation that such applications will be suitable without further modification, nor recommends the use of its products for application that may present a risk to human life due to malfunction or otherwise. Azoteq products are not authorized for use as critical components in life support devices or systems. No licenses to patents are granted, implicitly, express or implied, by estoppel or otherwise, under any intellectual property rights. In the event that any of the abovementioned limitations or exclusions does not apply, it is agreed that Azoteq's total liability for all losses, damages and causes of action (in contract, tort (including without limitation, negligence) or otherwise) will not exceed the amount already paid by the customer for the products. Azoteq reserves the right to alter its products, to make corrections, deletions, modifications, enhancements, improvements and other changes to the content and information, its products, programs and services at any time or to move or discontinue any contents, products, programs or services without prior notification. For the most up-to-date information and binding Terms and Conditions please refer to www.azoteq.com.

WWW.AZOTEQ.COM

info@azoteq.com