



# IQS232/43EV02 Evaluation Kit User Manual

IQ Switch® - ProxSense® Series

## Table of Contents

IQS232/43EV02 EVALUATION KIT USER MANUAL.....	1
TABLE OF CONTENTS .....	1
1 INTRODUCTION.....	1
2 EV-KIT MAINBOARD.....	1
3 MODULE BOARDS .....	2
4 REFERENCE DESIGNS.....	5

## 1 Introduction

This user manual describes the operation of the IQS232/43EV02 Evaluation Kit. The EV-Kit is manufactured in three parts, consisting of a mainboard, and three separate plug-in module boards. To adjust IC OTP settings, the main board can be interfaced to any personal computer with the Azoteq Configuration Tool (CTxxx), and making the adjustments by means of the USBProg software. The purpose of the IQS232/43EV02 EV-Kit is to help application and development engineers in evaluating the IQS232 and IQS243 proximity and touch sensors.

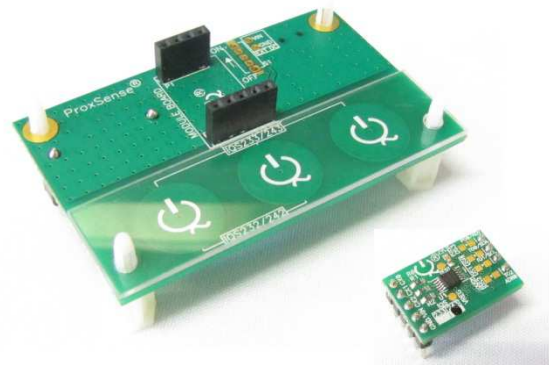

**Figure 2.1 IQS232/43EV02 Mainboard and controller modules**

## 2 EV-Kit Mainboard

Figure 2.1 illustrates the evaluation kit mainboard and the three supplied controller modules. The mainboard supplies power and other functions to the controller module boards and is easily operated. Simply plug in the desired module board into the mainboard and turn on the mainboard by means of the on/off slide switch. Features included in the EV-Kit mainboard:

- Modular design: Connect one of the supplied IC modules into the mainboard, or wire into a prototype for rapid prototyping
- Reference designs for IQS232 and IQS243 with user proximity & touch detection ability
- LEDs to indicate proximity AND contact to the buttons for IQS232

- Can be used in Data Streaming Mode:  
For details see the IQS232 and IQS243 datasheets (EV-KIT requires Azoteq Configuration Tool CT, or Azoteq Data Streamer DS)
- Can be used in Direct mode (IQS232 only): Battery or USB powered
- OTP bits can be programmed on the kit (requires CTxxx)

Figure 2.2 illustrates the bottom view of the EV-Kit mainboard. The EV-Kit is powered by two 3V coin cell batteries in series, which is regulated to 3.3V and supplied to the module board. The EV-Kit mainboard can also draw power from a USB source by means of the mini-USB connector provided on the mainboard.

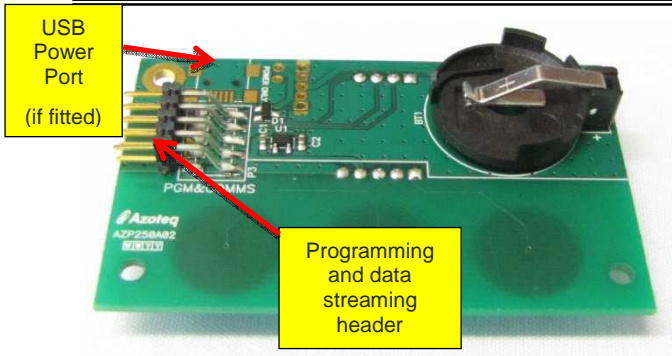

**Figure 2.2 Bottom view of EV-Kit mainboard**

The mainboard includes a programming and data streaming header as also illustrated in the figure.

The EV-Kit is interfaced to a personal computer for data streaming and programming OTP options, by means of the Azoteq Configuration Tool (CTxxx). For IC programming and visual data streaming please utilize the IQS232 GUI, IQS243 GUI and USBProg software, provided on the Azoteq website. ([www.azoteq.com](http://www.azoteq.com)).

### 3 Module Boards

#### 3.1 IQS232 Module board

Figure 3.1 illustrates the IQS232 Module board. Its features include:

- 1 x Proximity indication LED
- 2 x Touch indication LEDs (One for each channel)
- Small and compact PCB layout, which is easily wired to prototype applications

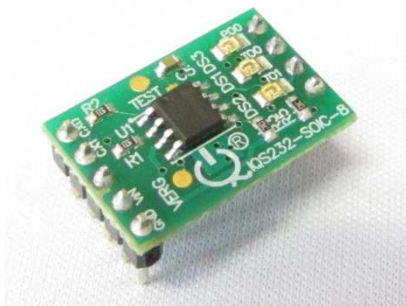

**Figure 3.1 IQS232 Module board**

Descriptions of the components are given in Table 3.1.

**Table 3.1 IQS232 Module board component description**

Component	Purpose	Typical value
C1, C2	Power supply decoupling capacitors	1µF, 100pF
C3, C4	Internal regulator decoupling capacitors	1µF, 100pF
R6, R7, R8	LED current limiting resistors	2kΩ
R1, R2	Sense electrode (Cx) series resistors (Added ESD Protection)	470Ω
R3, R4, R5	Debug mode pull-up resistors	10kΩ

#### 3.2 IQS243 Module Board

Figure 3.2 illustrates the IQS243 Module board. Its features include:

- I<sup>2</sup>C Communication interface
- Small and compact PCB layout, which can be easily wired to prototype applications

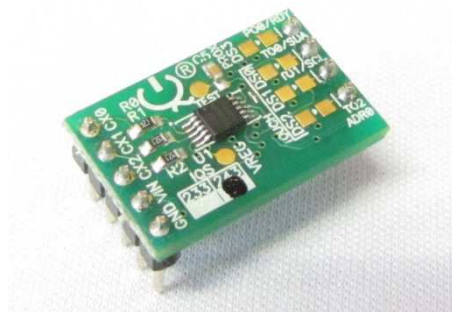

**Figure 3.2 Top view of the IQS243 module board**

Descriptions of the IQS243 module board components are given in Table 3.2.



**Table 3.2 IQS243 Module board component description**

CT200 Configuration Tool. The IQS243 GUI is used to stream and visualize data in real-time.

Component	Purpose	Typical value
C1, C2	Power supply decoupling capacitors	1 $\mu$ F, 100pF
C3, C4	Internal regulator decoupling capacitors	1 $\mu$ F, 100pF
R7	RDY pull-up resistor	4.7k $\Omega$
R8	SDA pull-up resistor	4.7k $\Omega$
R9	SCL pull-up resistor	4.7k $\Omega$
R10	Sub Address Select resistor	10k $\Omega$
R0, R1, R2	Sense electrode (Cx) series resistors (Added ESD Protection)	470 $\Omega$

For operation and data visualization, it is necessary to interface the IQS243 module to a personal computer by means of the Azoteq

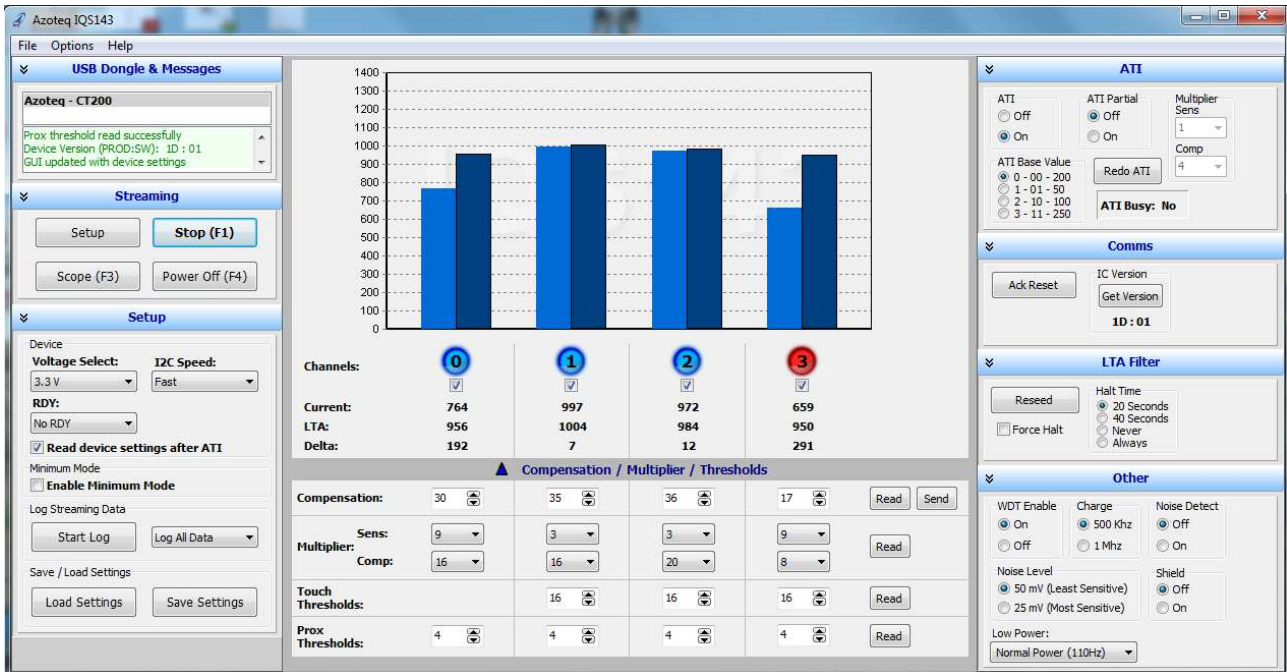

Figure 3.3 IQS243 Graphical User Interface

The IQS243 Software GUI can be downloaded from the following link:

[http://www.azoteq.com/images/stories/software/azoteq\\_iqs243\\_setup.zip](http://www.azoteq.com/images/stories/software/azoteq_iqs243_setup.zip)

- Plug in the IQS243 module into the Mainboard
- Connect the Mainboard to the Azoteq CT
- Run the IQS243 Software GUI and Click on "Start".

The GUI display is illustrated in Figure 3.4 where channel 3 shows a valid touch, and proximity is detected on all other channels.



## 4 Reference Designs

### 4.1 IQS232 Reference Design

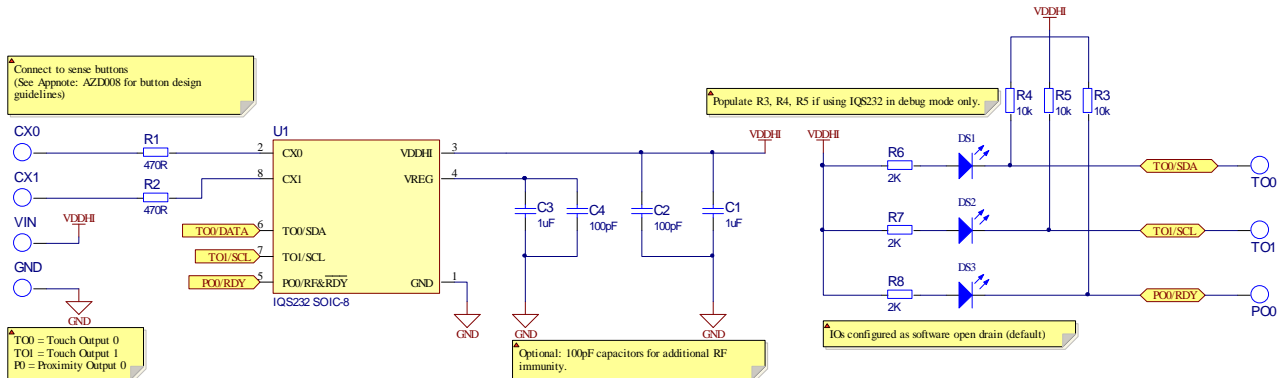

Figure 4.1 IQS232 Reference design

### 4.2 IQS243 Reference Design

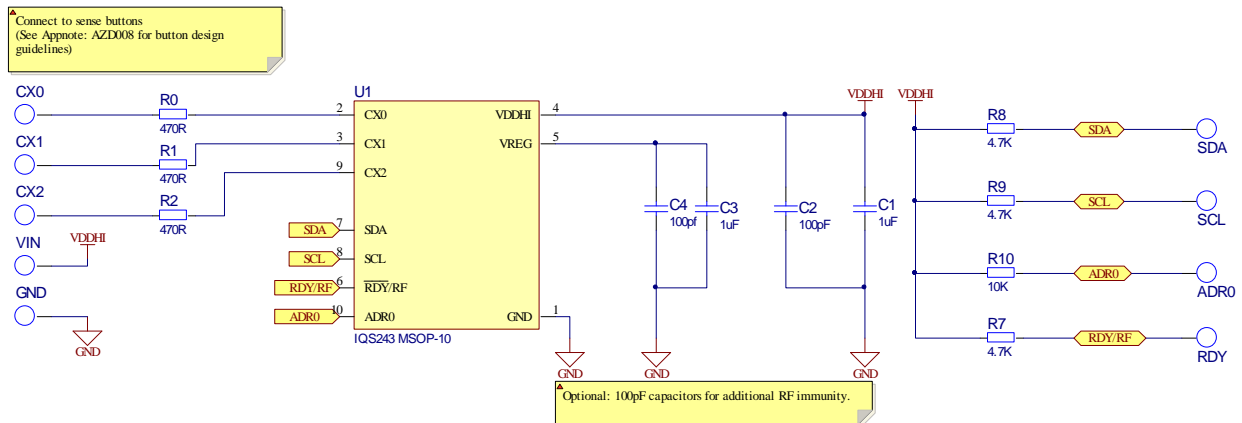



Figure 4.2 IQS243 Reference design



The following patents relate to the device or usage of the device: US 6,249,089 B1, US 6,621,225 B2, US 6,650,066 B2, US 6,952,084 B2, US 6,984,900 B1, US 7,084,526 B2, US 7,084,531 B2, US 7,119,459 B2, US 7,265,494 B2, US 7,291,940 B2, US 7,329,970 B2, US 7,336,037 B2, US 7,443,101 B2, US 7,466,040 B2, US 7,498,749 B2, US 7,528,508 B2, US 7,755,219 B2, US 7,772,781, US 7,781,980 B2, US 7,915,765 B2, EP 1 120 018 B1, EP 1 206 168 B1, EP 1 308 913 B1, EP 1 530 178 B1, ZL 99 8 14357.X, AUS 761094

IQ Switch<sup>®</sup>, ProxSense<sup>®</sup>, LightSense™, AirButton<sup>®</sup> and the  logo are trademarks of Azoteq.

The information in this Datasheet is believed to be accurate at the time of publication. Azoteq assumes no liability arising from the use of the information or the product. The applications mentioned herein are used solely for the purpose of illustration and Azoteq makes no warranty or representation that such applications will be suitable without further modification, nor recommends the use of its products for application that may present a risk to human life due to malfunction or otherwise. Azoteq products are not authorized for use as critical components in life support devices or systems. No licenses to patents are granted, implicitly or otherwise, under any intellectual property rights. Azoteq reserves the right to alter its products without prior notification. For the most up-to-date information, please refer to [www.azoteq.com](http://www.azoteq.com).

**[WWW.AZOTEQ.COM](http://WWW.AZOTEQ.COM)**

**[ProxSenseSupport@azoteq.com](mailto:ProxSenseSupport@azoteq.com)**