



# IQS158 Datasheet

## IQ Switch<sup>®</sup> - ProxSense<sup>®</sup> Series

8Channel Capacitive Sensor with Two-wire Serial Interface and Compensation for Sensitivity Reducing Objects

### Unparalleled Features

- ⌚ Automatic tuning for optimal operation in various environments
- ⌚ 8 Button capacitive sensor in 10 pin package

The IQS158 ProxSense<sup>®</sup> IC is a fully integrated 8 channel capacitive contact and proximity sensor with market leading sensitivity and automatic tuning to the sense electrodes. The IQS158 provides a cost effective implementation in a small outline package. The device is ready for use in a large range of applications while the two-wire serial interface provides full control to a host.

### Main Features

- ⌚ 8 Channel input device
- ⌚ Touch detection on all 8 keys with single Prox key – **OR** -
- ⌚ Touch detection on 7 keys with distributed Prox on 3 keys
- ⌚ Two-wire serial data output
- ⌚ ATI: Automatic tuning to optimum sensitivity
- ⌚ Supply Voltage 3V to 5.5V
- ⌚ Internal voltage regulator and reference capacitor
- ⌚ Large proximity detection range
- ⌚ Automatic drift compensation
- ⌚ Development tools available (VisualProxSense and USB dongles)
- ⌚ Small outline MSOP-10

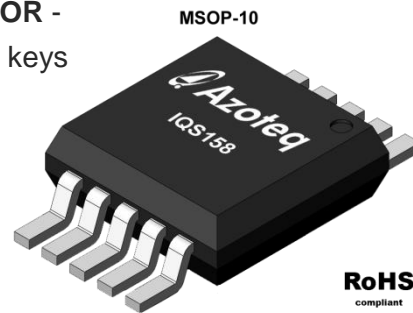

**RoHS**  
compliant

**MSOP-10**  
Representations only,  
not actual markings

### Applications

- ⌚ White goods and appliances
- ⌚ Office equipment, toys, sanitary ware
- ⌚ Flame proof, hazardous environment Human Interface Devices
- ⌚ Proximity detection that enables backlight activation (Azoteq Patent)
- ⌚ Wake-up from standby applications
- ⌚ Replacement for electromechanical switches
- ⌚ GUI trigger on proximity detection.

#### Available options

T <sub>A</sub>	MSOP-10
-40°C to 85°C	IQS158



## Functional Overview

### 1 Introduction

The IQS158 is an eight channel capacitive proximity and touch sensor featuring internal voltage regulator and reference capacitor ( $C_s$ ).

The device has five dedicated (and one shared) input pins for the connection of the sense electrodes, which comprises of three receivers, and three transmitters. Two output pins are used for serial data communication.

The device automatically tracks slow varying environmental changes via various filters, detects noise and has an Automatic Tuning Implementation (ATI) to tune the device for optimal sensitivity.

#### 1.1 Applicability

All specifications, except where specifically mentioned otherwise, provided by this datasheet are applicable to the following ranges:

- ⌚ Temperature  $-40^{\circ}\text{C}$  to  $+85^{\circ}\text{C}$
- ⌚ Supply voltage ( $V_{DDHI}$ ) 3V to 5.5V

#### 1.2 Pin-outs

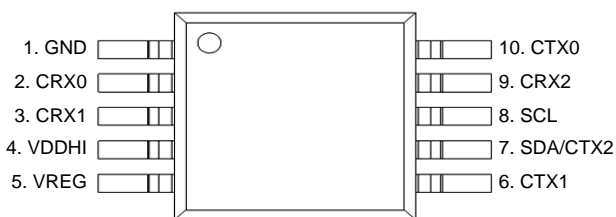

Figure 1.1 IQS158 Pin-outs.

Table 1.1 IQS158 Pin-outs.

Pin	Serial Data	Function
1	GND	Ground
4	VDDHI	Power Input
5	VREG	Regulator Pin
2	CRX0	Receive Electrode
3	CRX1	Receive Electrode
9	CRX2	Receive Electrode
10	CTX0	Transmit Electrode
6	CTX1	Transmit Electrode
7	SDA/CTX2	Data/Transmit Electrode
8	SCL	Clock

### 2 Analogue Functionality

The analogue circuitry measures the capacitance of the sense electrodes attached to the transmit and receive pins through a charge transfer process that is periodically initiated by the digital circuitry. The measuring process is referred to a conversion and consists of the discharging of  $C_s$  and  $C_x$ , the charging of  $C_x$  and then a series of charge transfers from  $C_x$  to  $C_s$  until a trip voltage is reached. The number of charge transfers required to reach the trip voltage is referred to as the count values (CS).

The capacitance measurement circuitry makes use of an internal  $C_s$  and voltage reference ( $V_{REG}$ ).



The analogue circuitry further provides functionality for:

- ⌚ Power on reset (POR) detection.
- ⌚ Brown out detection (BOD).
- ⌚ An on chip regulator further provides for accurate sampling and reduces BOM cost.

### 3 Digital Functionality

The digital processing functionality is responsible for:

- ⌚ Management of BOD and WDT events.
- ⌚ Initiation of conversions at the selected rate.
- ⌚ Processing of CS and execution of algorithms.
- ⌚ Monitoring and automatic execution of the ATI algorithm.
- ⌚ Signal processing and digital filtering.
- ⌚ Detection of PROX and TOUCH events.
- ⌚ Managing outputs of the device.
- ⌚ Managing serial communications.

## Detailed Description

### 4 Reference Design

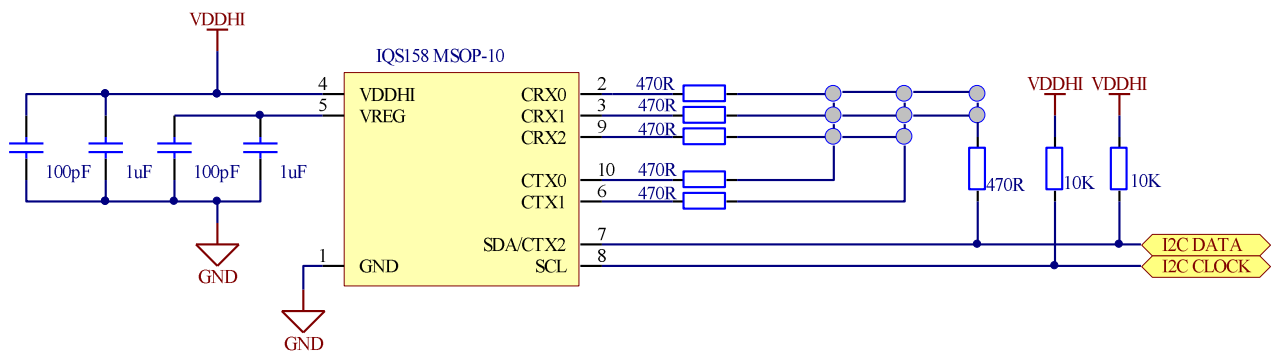

**Figure 4.1 Reference Design.**

- ⌚ Use C3 and C4 for added RF immunity.
- ⌚ Place C1-C4 as close as possible to IC, connected to good GND.
- ⌚ R7 and R8 used as optional (for long tracks, 20k pull-up resistors internal) pull up resistors for two-wire serial protocol.
- ⌚ Refer to Application Note on key pad design

### 5 High Sensitivity

Through patented design and advanced signal processing, the device is able to provide extremely high sensitivity to detect Proximity. This enables designs that can detect proximities at distances that cannot be equalled by most other products. When the device is used in environments where noise or ground effects exist that lower the sensitivity, a reduced proximity threshold is proposed to ensure reliable functioning of the sensor.

### 6 Adjustable Proximity Threshold

The IQS158 has a single proximity detection channel. The channel can be set to single (CTX0 & CRX0, with 8 touch keys) or distributed (CTX0 & CRX0 + CRX1 + CRX2, with 7 touch keys). The IQS158 has a default proximity threshold of 4. The proximity threshold is selected by the designer (1 to 63) to obtain the desired sensitivity and noise immunity through the two-wire serial interface. The proximity event is triggered based on the selected proximity threshold; the CS and LTA (Long Term



Average). The threshold is expressed in terms of counts; the same as CS.

A proximity event is identified when for at least 4 consecutive samples the following equation holds:

$$P_{TH} < LTA - CS$$

Where LTA is the Long Term Average

## 7 Adjustable Touch Thresholds

The IQS158 has a default touch threshold of  $24/64 \times LTA$  (for all 8 channels). Each channel has 14 different selectable touch thresholds (as a fraction of the LTA). The touch thresholds are selected by the designer to obtain the desired touch sensitivity for each channel. A touch threshold is expressed as a fraction of the LTA as follows:

$$T_{TH} = \text{Selected Touch Threshold} \times LTA$$

Where LTA is the Long Term Average

The touch event is triggered based on  $T_{TH}$ , CS and LTA. A touch event is identified when for at least 4 consecutive samples the following equation holds:

$$T_{TH} < LTA - CS$$

With lower average CS (therefore lower LTA) values the touch threshold will be lower and vice versa. For available selections, please refer to Section 9.5.9.

## 8 Charge Transfers

The IQS158 samples in 8 timeslots, with one internal Cs capacitor. The charge sequence is shown in Figure 8.1, where CH0 is the Prox channel, and charges before each of the 7 touch channels.

To improve touch performance, the charge sequence can be changed to fast order, illustrated in Figure 8.2. The Prox channel is only charged once before the 7 touch channels are charged.

CH0 is realised by CTX0, and CRX0 (for single, which also forms a touch channel), or with CTX0 & CRX0 + CRX1 + CRX2. Therefore: CH0 is a distributed electrode

formed by one transmitter and 3 receive electrodes.

The channel numbering is indicated in Figure 8.3.

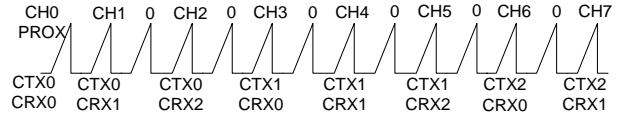

**Figure 8.1 IQS158 Charge transfer (default).**

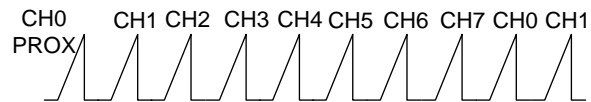

**Figure 8.2 IQS158 Charge transfer (Fast order).**

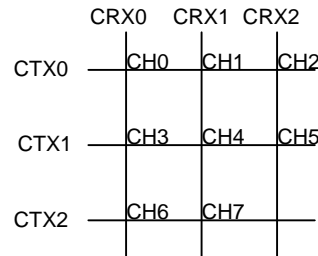

**Figure 8.3 IQS158 channel numbering.**

### 8.2 Long Term Average (LTA)

Capacitive touch devices detect changes in capacitance that are not always related to the intended proximity or touch of a human. This is a result of changes in the environment of the sense plate and other factors. These changes need to be compensated for in various manners in order to reliably detect touch events and especially to detect proximity events. One mechanism the IQS158 employs is the use of a Long Term Averaging filter (IIR type filter) which tracks slow changes in the environment (expressed as changes in the counts). The result of this filter is a Long Term Average (LTA) value that forms a dynamic reference used for various functions such as identification of proximity and touch events.



The LTA is calculated from the counts (CS). The filter only executes while no proximity or touch event is detected to ensure compensation only for environmental changes. However there may be instances where sudden changes in the environment or changes in the environment while a proximity or touch event has been detected cause the CS to drift away from the LTA. To compensate for these situations a Halt Timer ( $t_{HALT}$ ) has been defined.

The Halt Timer is started when a proximity or touch event occurs and when it expires the LTA filter is recalibrated. Recalibration causes  $LTA > CS$ , thus the disappearance of proximity or touch events.

The designer needs to select a Halt Timer value to best accommodate the required application. Refer to Section 0 for  $t_{HALT}$  timings.

Refer to Application note “AZD024 – Graphical Representation of the IIR Filter” for details regarding the execution of the LTA filter.

## 9 Data Streaming

The IQS158 device interfaces to a master controller via a 2 wire serial interface bus that is I<sup>2</sup>C<sup>™</sup> compatible, with minor deviations.

The IQS158 only functions as a slave device on the bus (but not with other devices). The bus is controlled by a master device which generates the serial clock (SCL), controls bus access, and generates the START and STOP conditions.

The serial clock (SCL) and serial data lines (SDA) are open-drain (during communication window) and therefore must be pulled high to the operating voltage with a pull-up resistor (typically 10k). These external pull-up resistors are only required for applications with very long communication lines. The IQS158 has internal pull-ups (20k) which are active in the communication window. Outside the communication window, the data line is used as the third transmit electrode (CTX2), and the internal 20k pull-up resistor is not connected. After power on, the master device should wait approximately 8ms before initiating communication with the IQS158.

### 9.1 Communication Window

Outside the communication window, the IQS158 keeps the SCL line low (during conversions, the SDA line functions as a transmit electrode). Thus the master device should monitor when the IQS158 releases the clock line (and SDA is high), as indication when the communication window is open.

### 9.2 Bus Characteristics

The following bus protocol has been defined:

- ⚡ Data transfer may only be initiated when the bus is not busy
- ⚡ During data transfer the data line must remain stable whenever the clock line is HIGH. Changes in the data line while the clock is HIGH will be interpreted as START and STOP conditions.

The following conditions have been defined for the bus (refer to Figure 9.1):

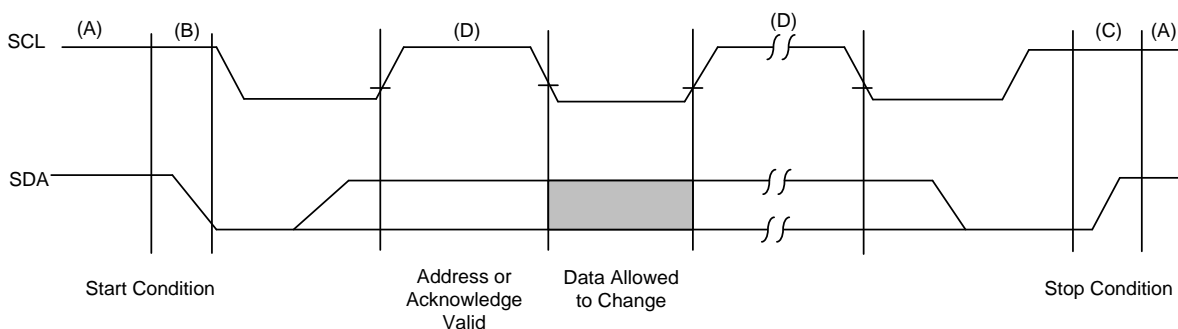

Figure 9.1 Data Transfer Sequence on the Serial Bus.



### 9.2.2 Bus Idle (A)

The SCL and SDA lines are both HIGH.

### 9.2.3 START Condition (B)

A start condition is implemented as a HIGH to LOW transition of SDA, while the SCL is HIGH. All serial communication must be preceded by a START condition.

### 9.2.4 STOP Condition (C)

A stop condition is implemented as a LOW to HIGH transition of SDA, while the SCL is HIGH. All serial communication must be ended by a STOP condition. NOTE: When a STOP condition is sent, the device will exit the communications window and continue with conversions.

### 9.2.5 Data Valid (D)

The state of the SDA line represents valid data when, after a START condition, the SDA is stable for the duration of the HIGH period of the clock signal.

The data on the line must be changed during the LOW period of the clock signal. There is one clock pulse per bit of data.

Each data transfer is initiated with a START condition and terminated with a STOP condition.

### 9.2.6 Acknowledge

The slave device must acknowledge (ACK) after the reception of each byte. The master device must generate an extra (9th) clock pulse which is associated with this acknowledge bit. The device that

acknowledges, has to pull down the SDA line during the acknowledge clock pulse. NOTE: The IQS158 does not generate any acknowledge bits while it is not in its communication window.

## 9.3 Control Byte Format

A control byte is the first byte received following the start condition from the master device. The control byte consists of a 7 bit device address and the Read/Write indicator bit (refer to Figure 9.2). The Read/Write bit should be 1 when reading from the device, thus a control byte of 0x89. Alternatively the Read/Write bit should be 0 when writing to the device, thus a control byte of 0x88.

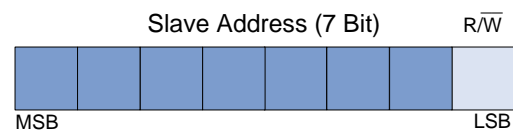

Figure 9.2 Control Byte Format.

## 9.4 Sub addressing

Each slave device on the serial bus requires a unique 7 bit device identifier. When the control byte is sent by the master the device will be able to determine if it is the intended recipient of a data transaction. The IQS158 address (0x44), unlike normal I<sup>2</sup>C devices, cannot function with other devices on a bus due to the SDA line that is shared with the TX0 line.



## 9.5 Memory Mapping

Address	Size(Bytes)		
00h-0Fh	16	Device Information	R/W
			R
10h-30h	32	Device Specific Data	R/W
			R
31h-34h	4	Proximity Status Bytes	R/W
			R
35h-38h	4	Touch Status Bytes	R/W
			R
39h-3Ch	4	Halt Bytes	R/W
			R
3Dh-41h	4	Active Bytes (indicate cycle)	R/W
			R
42h-82h	64	Counts	R/W
			R



83h-C3h

64

LTAs	R/W
	R
	R

C4h-FDh

64

Device Settings	R/W
	W
	W

### 9.5.1 Device Information

00H

Product Number									R/W
Bit	7	6	5	4	3	2	1	0	
	17 (decimal)								R

01H

Version Number									R/W
Bit	7	6	5	4	3	2	1	0	
	17 (decimal)								R

### 9.5.2 Device Specific Data

10H

Prox Status Bits									R/W
Bit	7	6	5	4	3	2	1	0	
	System use	System use	System use			ATI Busy	RF Noise		R

### 9.5.3 Proximity Status Bytes

The proximity status of all the channels on the device are shown here.



31H	Proximity 0 (CH0)								R/W	
	Bit	7	6	5	4	3	2	1	0	
		SHOW_RESET							CH0	R

SHOW_RESET	Bit set after reset condition (ex: BOD or WDT reset): ‘0’ = Default ‘1’ = Reset Occurred
------------	--

### 9.5.4 Touch Status Bytes

The touch status of all the channels on the device are shown here.

35H	Touch 0 (CH0-CH7)								R/W	
	Bit	7	6	5	4	3	2	1	0	
		CH7	CH6	CH5	CH4	CH3	CH2	CH1	CH0	R

### 9.5.5 Halt Bytes

The filter halt status of all the channels on the device are shown here.

39H	Halt 0 (CH0-CH7)								R/W	
	Bit	7	6	5	4	3	2	1	0	
		CH7	CH6	CH5	CH4	CH3	CH2	CH1	CH0	R

### 9.5.6 Channel Number (indicate cycle the channel number that the data in this cycles represents)

3DH	CHAN_NUM								R/W	
	Bit	7	6	5	4	3	2	1	0	
										R

### 9.5.7 Counts

The values that are available here are only the transfers from the current cycle indicated by the channel number (3DH).

42H	Counts								R/W	
	Bit	7	6	5	4	3	2	1	0	
		HIGH byte								R



43H	Counts								R/W	
	Bit	7	6	5	4	3	2	1	0	
	LOW byte								R	

### 9.5.8 Long-Term Averages

The values that are available here are only the transfers from the current cycle indicated by the channel number (3DH).

83H	Long-Term Average								R/W	
	Bit	7	6	5	4	3	2	1	0	
	HIGH byte								R	

84H	Long-Term Average								R/W	
	Bit	7	6	5	4	3	2	1	0	
	LOW byte								R	

### 9.5.9 Device Settings

It is attempted that the common used settings are situated closer to the top of the memory block. Settings that are regarded as more 'once-off' are placed further down.

C4H	Channel 0 Compensation Setting								R/W	
	Bit	7	6	5	4	3	2	1	0	
	Compensation 0 <5:0>								R/W	

Comp5:Comp0	Sets the compensation value for channel 0
	Can set the counts outside the ATI routine limit if "ATI OFF" is not set. This event will trigger re-ATI.

C5H	Channel 1 Compensation Setting								R/W	
	Bit	7	6	5	4	3	2	1	0	
	Compensation 1 <5:0>								R/W	



Comp5:Comp0	Sets the compensation value for channel 1
	Can set the counts outside the ATI routine limit if “ATI OFF” is not set. This event will trigger re-ATI.

**C6H**

Channel 2 Compensation Setting									R/W
Bit	7	6	5	4	3	2	1	0	
	Compensation 2 <5:0>								R/W

Comp5:Comp0	Sets the compensation value for channel 2
	Can set the counts outside the ATI routine limit if “ATI OFF” is not set. This event will trigger re-ATI.

**C7H**

Channel 3 Compensation Setting									R/W
Bit	7	6	5	4	3	2	1	0	
	Compensation 3 <5:0>								R/W

Comp5:Comp0	Sets the compensation value for channel 3
	Can set the counts outside the ATI routine limit if “ATI OFF” is not set. This event will trigger re-ATI.

**C8H**

Channel 4 Compensation Setting									R/W
Bit	7	6	5	4	3	2	1	0	
	Compensation 4 <5:0>								R/W



Comp5:Comp0	Sets the compensation value for channel 4
	Can set the counts outside the ATI routine limit if “ATI OFF” is not set. This event will trigger re-ATI.

C9H

Channel 5 Compensation Setting									R/W
Bit	7	6	5	4	3	2	1	0	
	Compensation 5 <5:0>								R/W

Comp5:Comp0	Sets the compensation value for channel 5
	Can set the counts outside the ATI routine limit if “ATI OFF” is not set. This event will trigger re-ATI.

CAH

Channel 6 Compensation Setting									R/W
Bit	7	6	5	4	3	2	1	0	
	Compensation 6 <5:0>								R/W

Comp5:Comp0	Sets the compensation value for channel 6
	Can set the counts outside the ATI routine limit if “ATI OFF” is not set. This event will trigger re-ATI.

CBH

Channel 7 Compensation Setting									R/W
Bit	7	6	5	4	3	2	1	0	
	Compensation 7 <5:0>								R/W



Comp5:Comp0	Sets the compensation value for channel 7
	Can set the counts outside the ATI routine limit if “ATI OFF” is not set. This event will trigger re-ATI.

**CCH**

CH0 Touch Threshold									R/W
Bit	7	6	5	4	3	2	1	0	
	TTH2	TTH1	TTH0	Multiplier 0 <4:0>					R/W

Multiplier Settings registers sets the Multiplier values for each channel, which determines the sensitivity, and compensation to reach ATI routine target.

Mul4:Mul3	Sensitivity Multiplier
Mul2:Mul0	Compensation Multiplier
	Can set the counts outside the ATI routine limit if “ATI OFF” is not set. This event will trigger re-ATI.

**CDH**

CH1 Touch Threshold									R/W
Bit	7	6	5	4	3	2	1	0	
	TTH2	TTH1	TTH0	Multiplier 0 <4:0>					R/W

**CEH**

CH2 Touch Threshold									R/W
Bit	7	6	5	4	3	2	1	0	
	TTH2	TTH1	TTH0	Multiplier 0 <4:0>					R/W

**CFH**

CH3 Touch Threshold									R/W
Bit	7	6	5	4	3	2	1	0	
	TTH2	TTH1	TTH0	Multiplier 0 <4:0>					R/W



D0H

CH4 Touch Threshold									R/W
Bit	7	6	5	4	3	2	1	0	
	TTH2	TTH1	TTH0	Multiplier 0 <4:0>					R/W

D1H

CH5 Touch Threshold									R/W
Bit	7	6	5	4	3	2	1	0	
	TTH2	TTH1	TTH0	Multiplier 0 <4:0>					R/W

D2H

CH6 Touch Threshold									R/W
Bit	7	6	5	4	3	2	1	0	
	TTH2	TTH1	TTH0	Multiplier 0 <4:0>					R/W

D3H

CH7 Touch Threshold									R/W
Bit	7	6	5	4	3	2	1	0	
	TTH2	TTH1	TTH0	Multiplier 0 <4:0>					R/W

Bits	Selection (TTH_Range = 0)	Selection (TTH_Range = 1)
000	24/64 * LTA	4/64 * LTA
001	4/64 * LTA	1/64 * LTA
010	8/64 * LTA	2/64 * LTA
011	16/64 * LTA	3/64 * LTA
100	32/64 * LTA	6/64 * LTA
101	40/64 * LTA	8/64 * LTA
110	48/64 * LTA	12/64 * LTA
111	56/64 * LTA	16/64 * LTA



D4H

		Proximity Sensitivity Settings CH 0 (PROX_TH_CH0)							R/W
Bit	7	6	5	4	3	2	1	0	
			PTH_5	PTH_4	PTH_3	PTH_2	PTH_1	PTH_0	R/W
<b>Default</b>			0	0	0	1	0	0	

PROX_TH	Sets a value between 1 and 63
---------	-------------------------------

D5H

		Touch Threshold Range Selection Bits CH0-CH7 (TTH_Range)							R/W
Bit	7	6	5	4	3	2	1	0	
	CH7 low Range	CH6 low Range	CH5 low Range	CH4 low Range	CH3 low Range	CH2 low Range	CH1 low Range	CH0 low Range	R/W
<b>Default</b>	0	0	0	0	0	0	0	0	

CH7 low Range:CH0 low Range	Select the low or normal range for Touch Thresholds: ‘0’: Normal Range ‘1’: Low Range
-----------------------------------	---



D6H

	ProxSense Module Settings 0 (PROX_SETTINGS0)								R/W
Bit	7	6	5	4	3	2	1	0	
		ATI Off	Partial ATI				Base 1	Base 0	R/W
<b>Default</b>	0	0	0	0	0	0	0	0	

ATI OFF	<p>If this bit is set, the ATI routine will not be able to run:</p> <p>'0': Disabled '1': Enabled</p>
Partial ATI	<p>Disables the Base bits to set the base value for the Prox Channel</p> <p>"0": Disabled "1": Enabled</p>
Base1:Base0 Partial ATI = 0	<p>Controls the base value for the ATI routine of the Prox channel, if Partial ATI = 0:</p> <p>'00': 200 '01':50 '10': 150 '11': 250</p>



D7H

ProxSense Module Settings 1 (PROX_SETTINGS1)									R/W
Bit	7	6	5	4	3	2	1	0	
	CTX Float	CRX Float	Re-ATI Current Channel	Noise Level	Noise Detect ON	Force Halt	Redo ATI	Reseed	R/W
<b>Default</b>	0	0	0	0	0	0	0	0	

CTX Float	Selects if CTX should be grounded between conversions. ‘0’: Grounded ‘1’: Floating
CRX Float	Selects if CRX should be grounded between conversions. ‘0’: Grounded ‘1’: Floating
Re-ATI Current Channel	‘0’: Disabled ‘1’: Enabled
ND Level	Selects the noise detect level ‘0’: 25mV ‘1’: 50mV
ND On	Enables the noise detection. ‘0’: Disabled ‘1’: Enabled
Force Halt	Forces the Long Term Average of all channels to stop being calculated ‘0’: LTA updates normally ‘1’: LTA is halted
Redo ATI	Forces the ATI routine to run when a ‘1’ is written into this bit position. ATI OFF in D3 takes priority.
Reseed	All channels are reseeded when a ‘1’ is written into this bit position. The LTA’s are set to 8 counts below the counts.



D8H

		ProxSense Module Settings 2 (PROX_SETTINGS2)							R/W
Bit	7	6	5	4	3	2	1	0	
	Ack Reset	WDT OFF	Halt Charge	Halt1	Halt0		Prox Single	Fast Order	R/W
<b>Default</b>	0	0	0	0	0	0	0	0	

Ack Reset	Clears the Show_Reset bit in 31H (Proximity 0) bit 7 '0' = default '1' = Clear Show reset
WDT Off	Sets the watchdog timer: '0' = Enabled '1' = Disabled
Halt Charge	Sets the IQS158 in a sleep mode (no conversions): '0' = Disabled '1' = Enabled Wake by pin change on SDA or SCL
Halt1:Halt0	Sets the Halt time for the LTA (time before recalibration): '00' = 20 Seconds '01' = 40 Seconds '10' = Never '11' = Permanent (Prox is 40 Seconds)
Prox Single	Selects which CRX's to use with CTX0 for the PROX channel '0' = Distributed (CRX0, CRX1 & CRX2) '1' = Single (CRX0 only)
Fast Order	Increase Touch Report Rate by changing charge transfer sequence: '0' = Charge Prox channel before every touch channel (See Figure 8.1) '1' = Charge all the touch channels before the prox channel (See Figure 8.2)



D9H

Channel Enable for CH0 – CH7 (CHAN_ACTIVE)									R/W
Bit	7	6	5	4	3	2	1	0	
	CH7	CH6	CH5	CH4	CH3	CH2	CH1	CH0	R/W

CH7:CH0	Software enable or disable of channels: ‘0’ = Channel Disabled ‘1’ = Channel Enabled
---------	--

DAH

DEFAULT_COMMS_POINTER									R/W
Bit	7	6	5	4	3	2	1	0	
Default	10H (beginning of Device Specific Data)								R/W

FCH

Direct Address R/W									R/W
Bit	7	6	5	4	3	2	1	0	
	Address location to perform Direct Read/Write								W

FDH

Direct Data R/W									R/W
Bit	7	6	5	4	3	2	1	0	
	Data to Read/Write								R/W

## 10 Auto Tuning Implementation (ATI)

ATI is a sophisticated technology implemented in the latest generation ProxSense<sup>™</sup> devices that optimises the performance of the sensor in a wide range of applications and environmental conditions (refer to application note AZD0027 - Auto Tuning Implementation).

ATI adjusts internal circuitry according to two parameters, the ATI multiplier and the ATI compensation. The ATI multiplier can be

viewed as a course adjustment and the ATI compensation as a fine adjustment.

The adjustment of the ATI parameters will result in variations in the counts and sensitivity. Sensitivity can be observed as the change in counts as the result of a fixed change in sensed capacitance. The ATI parameters have been chosen to provide significant overlap. It may therefore be possible to select various combinations of ATI multiplier and ATI compensation settings to obtain the same count values. The sensitivity



of the various options may however be different for the same counts.

## 10.1 Automatic ATI

The IQS158 implements an automatic ATI algorithm. This algorithm automatically adjusts the ATI parameters to optimise the sense electrodes connection to the device. On start-up the IQS158 configure all the channels, but is also able to re-ATI individual channels during operation.

The device will execute the ATI algorithm whenever the device starts-up and when the counts are not within a predetermined range.

While the Automatic ATI algorithm is in progress this condition will be indicated in the streaming data and proximity and touch events cannot be detected. The device will only briefly remain in this condition and it will be entered only when relatively large shifts in the counts has been detected.

The automatic ATI function aims to maintain a constant count value, regardless of the capacitance of the sense electrodes (within the maximum range of the device).

The effects of auto-ATI on the application are the following:

- ⌚ Automatic adjustment of the device configuration and processing parameters for a wide range of PCB and application designs to maintain an optimal configuration for proximity and touch detection.
- ⌚ Automatic tuning of the sense electrodes at start-up to optimise the sensitivity of the application.
- ⌚ Automatic re-tuning when the device detects changes in the sense electrodes capacitance to accommodate a large range of changes in the environment of

the application that influences the sensing electrodes.

- ⌚ Re-tuning only occurs during device operation when a relatively large sensitivity reduction is detected. This is to ensure smooth operation of the device during operation.
- ⌚ Re-tuning may temporarily influences the normal functioning of the device, but in most instances the effect will be hardly noticeable.
- ⌚ Shortly after the completion of the re-tuning process the sensitivity of Proximity detection may be reduced slightly for a few seconds as internal filters stabilises.

Automatic ATI can be implemented so effectively due to the following reasons:

- ⌚ Excellent system signal to noise ratio (SNR).
- ⌚ Effective digital signal processing to remove AC and other noise.
- ⌚ The very stable core of the devices.
- ⌚ The built in capability to accommodate a large range of sensing electrode capacitances.

## 10.2 Partial ATI

By default (Address: D6H bit 5 = 0) the ATI routine sets the required base value of the touch channels to 250 counts. The required base value for the proximity channel is specified through I<sup>2</sup>C commands in address D3H bits [1:0] and is default 200.

Alternatively (Address: D6H bit 5 = 1), the user can set the multiplier bits through address CCH through D3H bits [5:0] and this would determine the sensitivity, and compensation (scaled) to reach the ATI target.

With the base value set, the Partial ATI routine would use a convergence technique with a fixed amount of steps to reach its aimed value. ATI



## 11 Specifications

### 11.1 Absolute Maximum Specifications

The following absolute maximum parameters are specified for the device:

*Exceeding these maximum specifications may cause damage to the device.*

⌚ Operating temperature	-40°C to 85°C
⌚ Supply Voltage (VDDHI – GND)	5.5V
⌚ Maximum pin voltage	VDDHI + 0.5V
⌚ Maximum continuous current (for specific Pins)	
⌚ Minimum pin voltage	GND - 0.5V
⌚ Minimum power-on slope	100V/s
⌚ ESD protection	±3kV
⌚ Maximum pin temperature during soldering	
⌚ Maximum body temperature during soldering	

**Table 11.1 IQS158 General Operating Conditions**

DESCRIPTION	Conditions	PARAMETER	MIN	TYP	MAX	UNIT
Supply voltage		V <sub>DDHI</sub>	3		5.5	V
Internal regulator output	2.95 ≤ V <sub>DDHI</sub> ≤ 5.0	V <sub>REG</sub>	2.35	2.50	2.65	V
Operating current	2.95 ≤ V <sub>DDHI</sub> ≤ 5.0	I <sub>IQS158</sub>		230		μA

**Table 11.2 Start-up and shut-down slope Characteristics**

DESCRIPTION	Conditions	PARAMETER	MIN	MAX	UNIT
POR	V <sub>DDHI</sub> Slope ≥ 100V/s	POR	0.92	2.3	V
BOD		BOD	1	1.54	V

**Table 11.3 Initial Touch Times**

DESCRIPTION	PARAMETER	MIN	MAX	Unit
BP <sup>1</sup>	Report Rate	81	259	ms

**Table 11.4 Repetitive Touch Rates**

DESCRIPTION	Conditions	PARAMETER	Sample rate = 5ms	Sample rate = 9ms	UNIT
All power modes	Zoom active	Response Rate <sup>2</sup>	>8	>3	Touches/second

<sup>1</sup> Communication and charge frequency to comply with sample rate as reported earlier in this datasheet.

<sup>2</sup> Debounce of 2 (up and down)



The sample rate of the IQS158 is increased by:

- ⌚ Faster communication
- ⌚ Less data transfer
- ⌚ Using the fast charge order selection of the IQS143

## 12 Mechanical Dimensions

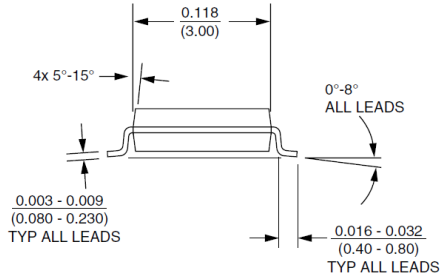

**Figure 12.1 MSOP-10 Back view.**

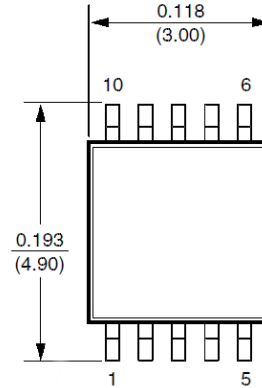

**Figure 12.3 MSOP-10 Top view.**

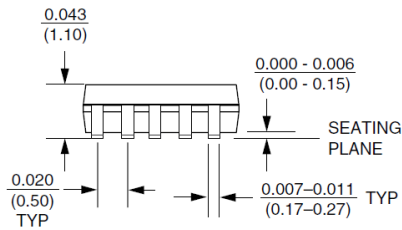

**Figure 12.2 MSOP-10 Side view.**

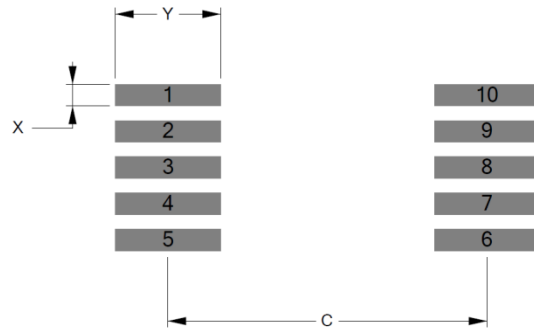

**Figure 12.4 MSOP-10 Footprint.**

**Table 12.1 MSOP-10 Footprint Dimensions from Figure 12.4.**

Dimension	[mm]
Pitch	0.50
C	4.40
Y	1.45
X	0.30



### 13 Device Marking

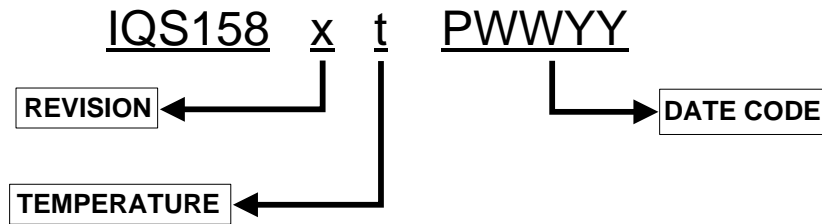

<b>REVISION</b>	<b>x</b>	=	IC Revision Number
<b>TEMPERATURE RANGE</b>	<b>t</b>	=	I    -40°C to 85°C (Industrial) C    0°C to 70°C (Commercial)
<b>DATE CODE</b>	<b>P</b>	=	Package House
	<b>WW</b>	=	Week
	<b>YY</b>	=	Year

### 14 Ordering Information

Orders will be subject to a MOQ (Minimum Order Quantity) of a full reel. Contact the official distributor for sample quantities. A list of the distributors can be found under the “Distributors” section of [www.azoteq.com](http://www.azoteq.com).

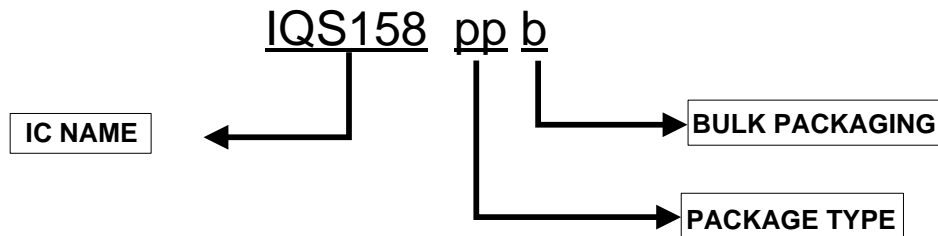

<b>IC NAME</b>	<b>IQS158</b>	=	IQS158
<b>PACKAGE TYPE</b>	<b>MS</b>	=	MSOP-10
<b>BULK PACKAGING</b>	<b>R</b>	=	Reel (4000pcs/reel) – MOQ = 4000pcs
	<b>T</b>	=	Tube (96pcs/tube, Special order)



---

## 15 Contact Information

### PRETORIA OFFICE

Physical Address  
160 Witch Hazel Avenue  
Hazel Court 1, 1<sup>st</sup> Floor  
Highveld Techno Park  
Centurion, Gauteng  
Republic of South Africa  
Tel: +27 12 665 2880  
Fax: +27 12 665 2883  
Postal Address  
PO Box 16767  
Lytelton  
0140  
Republic of South Africa

### PAARL OFFICE

Physical Address  
109 Main Street  
Paarl  
7646  
Western Cape  
Republic of South Africa  
Tel: +27 21 863 0033  
Fax: +27 21 863 1512  
Postal Address  
PO Box 3534  
Paarl  
7620  
Republic of South Africa

The following patents relate to the device or usage of the device: US 6,249,089 B1, US 6,621,225 B2, US 6,650,066 B2, US 6,952,084 B2, US 6,984,900 B1, US 7,084,526 B2, US 7,084,531 B2, US 7,119,459 B2, US 7,265,494 B2, US 7,291,940 B2, US 7,329,970 B2, US 7,336,037 B2, US 7,443,101 B2, US 7,466,040 B2, US 7,498,749 B2, US 7,528,508 B2, US 7,755,219 B2, US 7,772,781, US 7,781,980 B2, EP 1 120 018 B1, EP 1 206 168 B1, EP 1 308 913 B1, EP 1 530 178 B1, ZL 99 8 14357.X, AUS 761094

**IQ Switch<sup>®</sup>, ProxSense<sup>™</sup>, LightSense<sup>™</sup>, AirButton<sup>®</sup> and the IQ Logo are trademarks of Azoteq.**

The information appearing in this Datasheet is believed to be accurate at the time of publication. However, Azoteq assumes no responsibility arising from the use of the specifications described. The applications mentioned herein are used solely for the purpose of illustration and Azoteq makes no warranty or representation that such applications will be suitable without further modification, nor recommends the use of its products for application that may present a risk to human life due to malfunction or otherwise. Azoteq products are not authorized for use as critical components in life support devices or systems. No licenses to patents are granted, implicitly or otherwise, under any intellectual property rights. Azoteq reserves the right to alter its products without prior notification. For the most up-to-date information, please refer to [www.azoteq.com](http://www.azoteq.com).

**WWW.AZOTEQ.COM**

**ProxSenseSupport@azoteq.com**