



IQS152 Datasheet

IQ Switch[®] - ProxSense[®] Series

2Channel Capacitive Sensor with Compensation for Sensitivity Reducing Objects

The IQS152 ProxSense[®] IC is a fully integrated two channel capacitive contact and proximity sensor with market leading sensitivity and automatic tuning to the sense electrodes. The IQS152 provides a minimalist implementation requiring as few as 2 external components. The device is ready for use in a large range of applications while programming options allow customisation for specialized applications.

Main Features

- ⤵ 2 Channel input device
- ⤵ ATI: Automatic tuning to optimum sensitivity
- ⤵ Supply Voltage 3V to 5.5V
- ⤵ Internal voltage regulator and reference capacitor
- ⤵ OTP options:
 - ❖ Dycal[™]
 - ❖ Direct (logic level) and serial data output
 - ❖ 3 Low Power Modes (7 μ A min)
 - ❖ Proximity & Touch Thresholds
 - ❖ Active High or Active Low Output Option
- ⤵ Large proximity detection range
- ⤵ Automatic drift compensation
- ⤵ Development and Programming tools available (VisualProxSense and USBProg)
- ⤵ Small outline MSOP-10 package

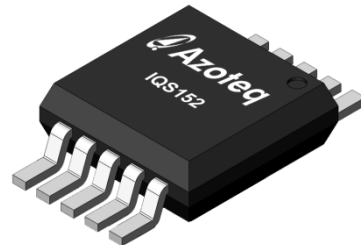

MSOP-10

Representations only,
not actual markings

Applications

- ⤵ Gesture recognition
- ⤵ White goods and appliances
- ⤵ Remote Controls
- ⤵ Office equipment, toys, sanitary ware
- ⤵ Flame proof, hazardous environment Human Interface Devices
- ⤵ Proximity detection that enables backlighting activation (Azoteq Patent)
- ⤵ Wake-up from standby applications
- ⤵ Replacement for electromechanical switches

Available options

T _A	MSOP-10
-40°C to 85°C	IQS152



Functional Overview

1 Introduction

The IQS152 is a two channel projected capacitive proximity and touch sensor featuring internal voltage regulator and reference capacitor (C_s).

The device has three dedicated pins for the connection of the sense electrodes (two receivers, CRx, and one transmitter, CTx). Output pins for proximity (PROX) and contact detection (TOUCH) on the PO and TO pins. The output pins can also be configured for serial data streaming option on TO0.

The devices automatically track slow varying environmental changes via various filters, detect noise and has an automatic Auto Tuning Implementation (ATI) to tune the device for optimal sensitivity.

1.1 Pin-outs

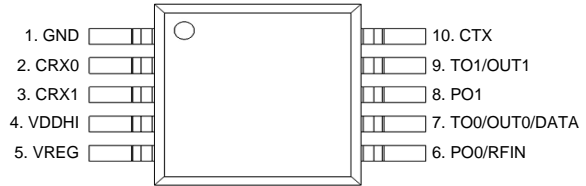

Figure 1.1 IQS152 Pin-outs MSOP-10.

Table 1.1 IQS152 Pin-outs

Pin	Stand-alone	Streaming	DYCAL™	Function
1	GND	GND	GND	Ground
2	CRX0	CRX0	CRX0	Sense Electrode
3	CRX1	CRX1	CRX1	Sense Electrode
4	VDDHI	VDDHI	VDDHI	Power
5	VREG	VREG	VREG	Regulated Output
6	PO0/RFIN	RFIN	RFIN	Prox output/ Noise detect
7	TO0	DATA	OUT0	Touch Output/Data Output
8	PO1			Proximity Output
9	TO1		OUT1	Touch Output
10	CTX	CTX	CTX	Transmit Electrode



1.2 Applicability

All specifications, except where specifically mentioned otherwise, provided by this datasheet are applicable to the following ranges:

- ⌚ Temperature -40C to +85C
- ⌚ Supply voltage (V_{DDHI}) 3V to 5.5V

2 Analogue Functionality

The analogue circuitry measures the capacitance of the sense electrodes attached to the Cx pins through a charge transfer process that is periodically initiated by the digital circuitry. The measuring process is referred to a conversion and consists of the discharging of C_s and Cx, the charging of Cx and then a series of charge transfers from Cx to C_s until a trip voltage is reached. The number of charge transfers required to reach the trip voltage is referred to as the count values (CS).

The capacitance measurement circuitry makes use of an internal C_s and voltage reference (V_{REG}).

The analogue circuitry further provides functionality for:

- ⌚ Power on reset (POR) detection.
- ⌚ Brown out detection (BOD).

3 Digital Functionality

The digital processing functionality is responsible for:

- ⌚ Device configuration from OTP settings after POR.
- ⌚ Management of BOD and WDT events.
- ⌚ Initiation of conversions at the selected rate.
- ⌚ Processing of CS and execution of algorithms.
- ⌚ Monitoring and automatic execution of the ATI algorithm.
- ⌚ Signal processing and digital filtering.
- ⌚ Detection of PROX and TOUCH events.
- ⌚ Managing outputs of the device.
- ⌚ Managing serial communications.
- ⌚ Manage programming of OTP options.
- ⌚ Selection of DYCAL™ operation



Detailed Description

4 Reference Design

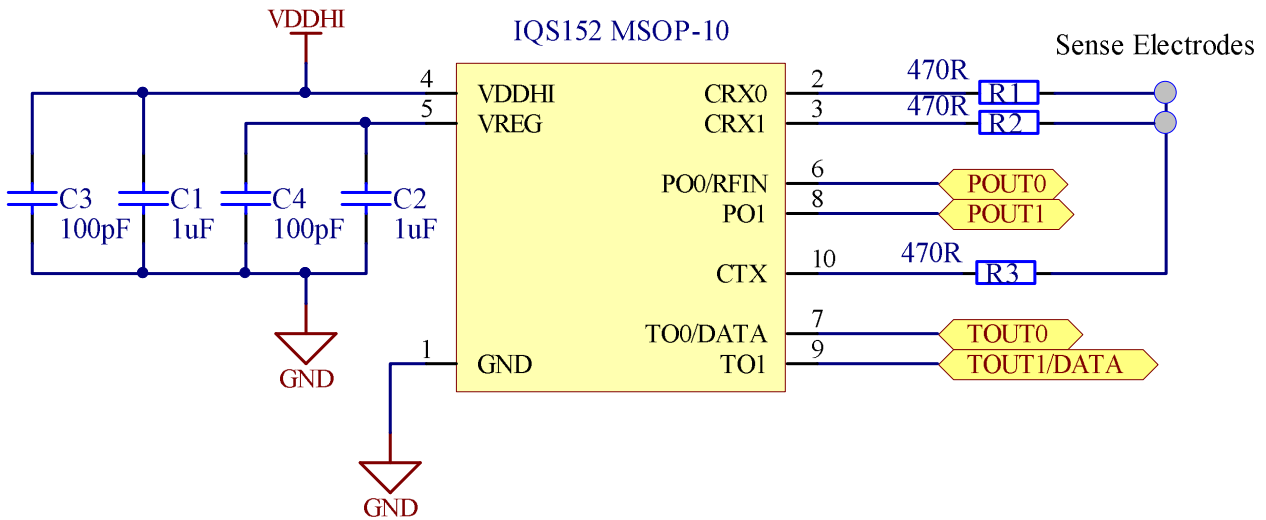

Figure 4.1 IQS152 Reference Design

- ⚡ Use C3 and C4 for added RF immunity.
- ⚡ Place C1-C4 as close as possible to the IC, connected to good GND.
- ⚡ TO0 & TO1 is default in active low
- ⚡ External pull-up (4k7) required on TO0 in data streaming mode

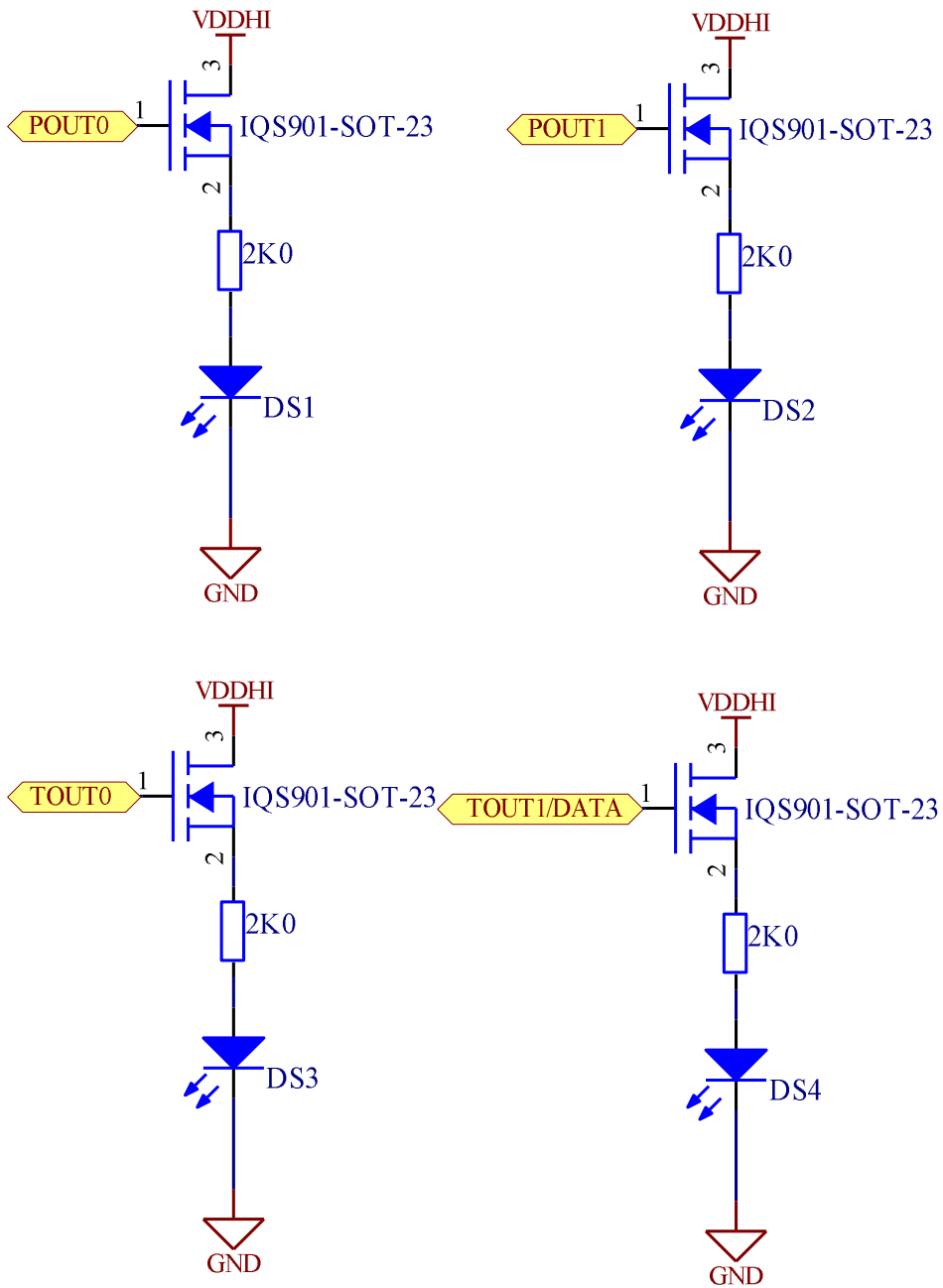

Figure 4.2 Output in active high (optional indicators).



5 High Sensitivity

Through patented design and advanced signal processing, the device is able to provide extremely high sensitivity to detect Proximity. This enables designs that can detect proximities at distances that cannot be equalled by most other products. When the device is used in environments where noise or ground effects exist that lower the sensitivity, a reduced proximity threshold is proposed to ensure reliable functioning of the sensor.



6 DYCAL™ Operation

Figure 6.1 Visual Representation of Dycal.

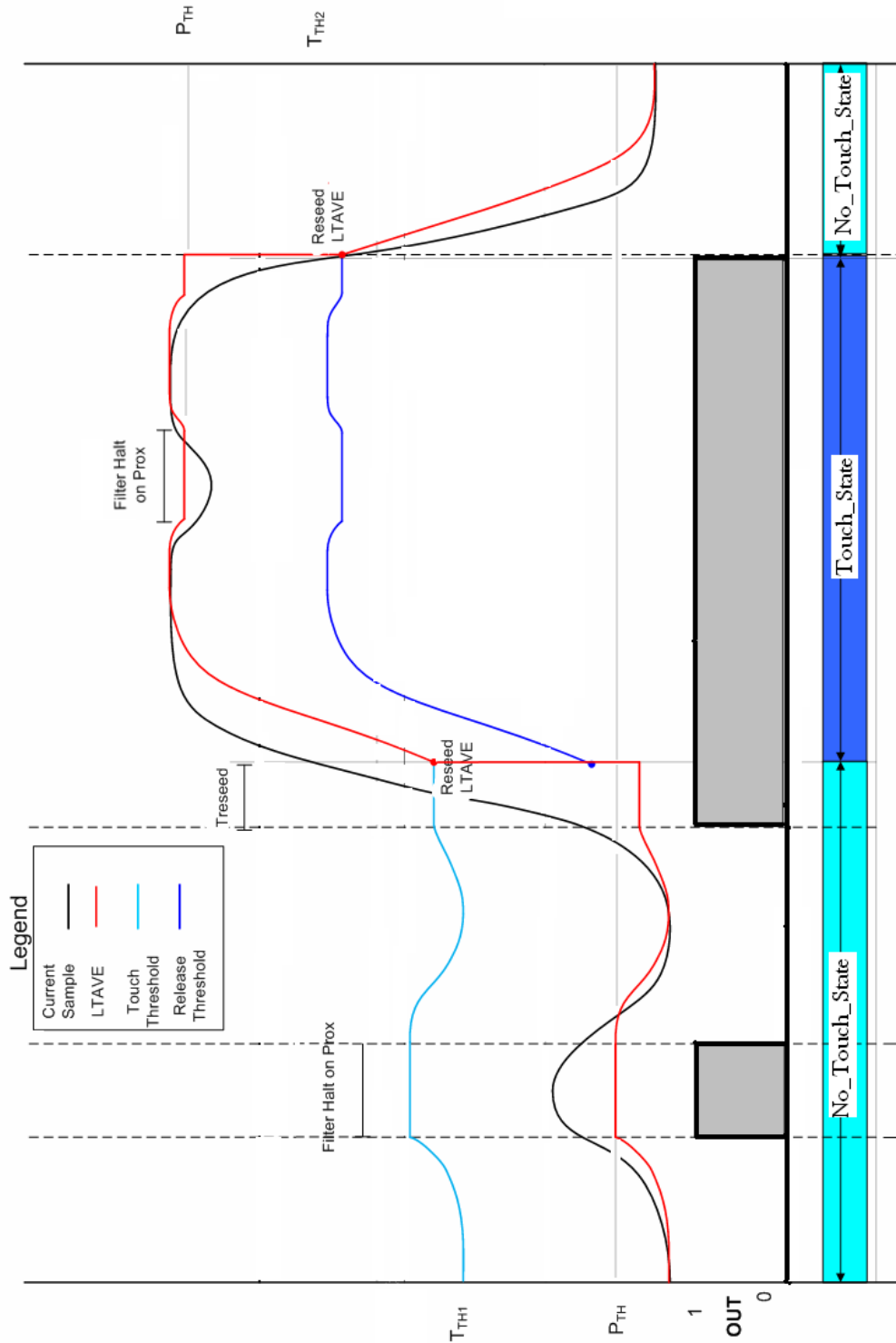



6.2 Dycal™ Operating Principle

When enabling the Dycal™ user interface in the OTP options (see Section 7 for OTP options) both channels are configured for Dycal™ operation. The touch outputs will then become outputs for the Dycal™ operation, in the same channel order. Proximity output pins function as normal. The IQS152 Dycal™ can be configured to output on Proximity or Touch (OTP option).

Figure 6.2 is a visual representation of the implemented functionality. The CS is displayed in black, the LT_{AVE} in red, the touch threshold in turquoise and the release threshold in blue. T_{TH1} represents the touch threshold which dynamically changes as the LT_{AVE} adapts to the CS when operating in the NO_TOUCH_STATE. T_{TH2} represents the release threshold when operating in the TOUCH_STATE.

P_{TH} (Proximity Threshold) setting is determined by the OTP selection. Refer to Section 8.1.

T_{TH1} (Touch Threshold) setting is determined by the OTP selection. Refer to Section 8.2. This threshold should be chosen sensitive enough to detect a touch (on ear or hand held detection) but not too sensitive to lose the condition with drift (softer hand held or press to ear).

T_{TH2} (Release Threshold) setting is a percentage of T_{TH1} . Refer to Section 8.4. This threshold is also adjustable to overcome stuck conditions.

From left to right: The IC detects a proximity condition and consequently halts the LT_{AVE} filter for a period (THALT) according to the OTP selections. (Refer to Section 8.4). When the change in the CS satisfies a Touch Condition after T_{RESEED} has timed out, the LT_{AVE} is reseeded and adjusts towards the CS. The sensor now changes and operates with reference to a Touch Condition in the TOUCH_STATE (this state is also realisable through a proximity event, if the Dycal™ output is selected on proximity, and not touch in the OTP options).

Operating in the TOUCH_STATE a proximity is detected when the CS exceeds the $Touch_LT_{AVE}$ with the proximity threshold value and consequently halts the LT_{AVE} . Releasing the sense pad causes the CS to decrease. When the CS value exceeds the dynamically tracking $Touch_LT_{AVE}$, the filter is halted once again due to the detection of the inverse proximity condition. When difference between the $Touch_LT_{AVE}$ and CS then exceeds the Release Threshold, the LT_{AVE} is reseeded and adapts towards the CS value. The output is deactivated and the sensor now operates with reference to the No-Touch LT_{AVE} in the NO_TOUCH_STATE or traditional state.

7 User Configurable Options

The IQS152 provides One Time Programmable (OTP) user options (each option can be modified only once). The device is fully functional in the default (unconfigured) state. OTP options are intended for specific applications.

The configuration of the device can be done on packaged devices or in-circuit. In-circuit configuration may be limited by values of external components chosen.

7.1 Configuring of Devices

Azoteq offers a Configuration Tool (CTxxx) and accompanying software (USBProg.exe) that can be used to program the OTP user options for prototyping purposes. More details regarding the configuration of the device with the USBProg program is explained by application note: “AZD007 – USBProg Overview” which can be found on the Azoteq website.

Alternate programming solutions of the IQS152 also exist. For further enquiries regarding this matter please contact Azoteq at ProxSenseSupport@azoteq.com or the local distributor.



Table 6-1: User Selectable Configuration Options: Bank 0

	P _{THR1} CH1 Dycal Sel	P _{THR0} CH1 Dycal Rel	T _{THR2} CH0	T _{THR1} CH0	T _{THR0} CH0	P _{THR1} CH0	P _{THR0} CH0
--	------------------------------------	------------------------------------	-----------------------	-----------------------	-----------------------	-----------------------	-----------------------

bit 7

bit 0

UI Select = 0

Bank 0: bit 6-5 **P_{THR1}: P_{THR0}:** Proximity Thresholds for CH1 Refer to Section 8.1 for more details

00 = 2

01 = 4

10 = 8

11 = 16

UI Select = 1

Bank 0: bit 6 **Dycal Sel:** Dycal Output Select Refer to Section 8.3 for more details

0 = On Touch

1 = On Proximity

Bank 0: bit 5 **Dycal Rel:** Dycal Release Refer to Section 8.4 for more details

0 = 50%

1 = 75%

Bank 0: bit 4 2 **CH0 T_{THR2}: CH0 T_{THR0}:** Touch Thresholds on CH0 Refer to Section 8.2 for more details

000 = 120

001 = 32

010 = 80

011 = 180

100 = 260

101 = 400

110 = 680

111 = 1000

Bank 0: bit 1-0 **P_{THR1}: P_{THR0}:** Proximity Thresholds for CH0 Refer to Section 8.1 for more details

00 = 2

01 = 4

10 = 8

11 = 16



Table 6-2: User Selectable Configuration Options: Bank 1

t_{HALT1}	t_{HALT0}	ATI	CH1 T_{THR2}	CH1 T_{THR1}	CH1 T_{THR0}	Base1	Base0
-------------	-------------	-----	----------------	----------------	----------------	-------	-------

bit 7 bit 0

Bank 1: bit 7-6 t_{HALT1} : t_{HALT0} : Halt time of Long Term Average Refer to Section 8.5 for more details

00 = 18 seconds

01 = 72 seconds

10 = 3 seconds

11 = Always (Prox on 18)

Bank 1: bit 5 **ATI:** ATI Select Section 10.2

0 = Full

1 = Partial

Bank 1: bit 4-2 **CH1 T_{THR2} :****CH1 T_{THR0} :** Touch Thresholds on CH1 Refer to Section 8.2 for more details

000 = 120

001 = 32

010 = 80

011 = 180

100 = 260

101 = 400

110 = 680

111 = 1000

Bank 1: bit1-0 **Base1:****Base0:** Proximity channel Base Value Refer to Section 8.6 for more details

00 = Base Value 200

01 = Base Value 50

10 = Base Value 100

11 = Base Value 250



Table 6-3: User Selectable Configuration Options: Bank 2

		STREAMING	Noise Detect	Power Mode1	Power Mode0	UI Select	LOGIC
--	--	-----------	--------------	-------------	-------------	-----------	-------

bit 7							bit 0
Bank 2: bit 5	STREAMING: 1-wire streaming mode					Refer to Section 8.7 for more details	
	0 = Disabled						
	1 = Enabled						
Bank 2: bit 4	ND: RF Noise Detect					Refer to Section 8.8 for more details	
	0 = Disabled						
	1 = Enabled						
Bank 2: bit3-2	Power Mode1:0: Power mode selection					Refer to Section 8.9 for more details	
	00 = 110Hz						
	01 = 27ms						
	10 = 128ms						
	11 = 512ms (128ms intervals)						
Bank 2: bit1	UI Select: Dycal enable					Refer to Section 8.10 for more details	
	0 = Normal						
	1 = Dycal						
Bank 2: bit0	LOGIC: Output logic select -					Refer to Section 8.11 for more details	
	0 = Active Low						
	1 = Active High						

8 Description of User Options

This section describes the individual user programmable options of the IQS152 in more detail.

The options are offered to fine tune for a specific application Azoteq can supply pre-configured devices for large quantities.

8.1 Adjustable Proximity Threshold

The IQS152 has 4 proximity threshold settings for each of the two input channels. The proximity threshold is selected by the designer to obtain the desired sensitivity and noise

immunity. The proximity event is triggered based on the selected proximity threshold; the CS and LTA (Long Term Average). The threshold is expressed in terms of counts; the same as CS. The threshold for CH1 is set as:

Configuration: Bank0 bit6-5

P_{THR1}:P_{THR0}: Proximity Thresholds CH1

Bit	Selection
00	2 (Most sensitive)
01	4
10	8
11	16 (Least sensitive)



The threshold for CH0 is separately set by:

Configuration: Bank0 bit1-0

P_{THR1}:P_{THR0}: Proximity Thresholds CH0

Bit	Selection
00	2 (Most sensitive)
01	4
10	8
11	16 (Least sensitive)

8.2 Adjustable Touch Thresholds

The IQS152 has 8 touch threshold settings for each of the two input channels. The touch threshold is selected by the designer to obtain the desired touch sensitivity. The threshold is expressed in terms of counts; the same as CS

The touch event is triggered based on T_{TH}, CS and LTA. A touch event is identified when for at least 4 consecutive samples of the following equation holds:

$$T_{TH} \leq LTA - CS$$

The touch thresholds for channel 0 and channel 1 are set separately as follow:

Configuration: Bank0 bit 4-2

TTHR0:TTHR2: Touch Thresholds CH0

Bit	Selection
000	120
001	32 (Most sensitive)
010	80
011	180
100	260
101	400
110	680
111	1000 (Least sensitive)

The Touch Threshold for CH1 is set as follow:

Configuration: Bank1 bit 4-2

TTHR0:TTHR2: Touch Thresholds

Bit	Selection
000	120
001	32 (Most sensitive)
010	80
011	180
100	260
101	400
110	680
111	1000 (Least sensitive)

8.3 Dycal™ Select

When the IQS152 is set up for Dycal operation (see Section 6), the user can select whether the outputs should become active upon proximity or touch detection. If “Dycal Sel” is set “On Touch”, the LTA will reseed “t_{HALT}” time after a proximity event was made, if no touch event follows before t_{HALT} time elapses.

Configuration: Bank0 bit6

Dycal Sel: Dycal Output Select

Bit	Selection
0	On Touch
1	On Prox

8.4 Dycal™ Release

The second touch threshold

Configuration: Bank0 bit5

Dycal Rel: Dycal output release

Bit	Selection
0	50%
1	75%

8.5 Filters used by the IQS152

The IQS152 devices employ various signal processing functions that includes the execution of various filters as described below.



8.5.1 Long Term Average (LTA)

Capacitive touch devices detect changes in capacitance that are not always related to the intended proximity or touch of a human. This is a result of changes in the environment of the sense plate and other factors. These changes need to be compensated for in various manners in order to reliably detect touch events and especially to detect proximity events. One mechanism the IQS152 employs is the use of a Long Term Averaging filter (IIR type filter) which tracks slow changes in the environment (expressed as changes in the count values). The result of this filter is a Long Term Average (LTA) value that forms a dynamic reference used for various functions such as identification of proximity and touch events.

The LTA is calculated from the counts (CS). The filter only executes while no proximity or touch event is detected to ensure compensation only for environmental changes. However there may be instances where sudden changes in the environment or changes in the environment while a proximity or touch event has been detected cause the CS to drift away from the LTA. To compensate for these situations a Halt Timer (t_{HALT}) has been defined.

The Halt Timer is started when a proximity or touch event occurs and when it expires the LTA filter is recalibrated. Recalibration causes $LTA > CS$, thus the disappearance of proximity or touch events.

The designer needs to select a Halt Timer value to best accommodate the required application.

Configuration: Bank1 bit7-6

$t_{HALT1}:t_{HALT0}$: Halt time of Long Term Average	
Bit	Selection
00	18 seconds
01	72 seconds
10	3second
11	ALWAYS (Prox on 18 seconds)

Notes:

- With the 'ALWAYS' (bit selection "11") option and the detection of a proximity

event the execution of the filter will be halted for only 18 seconds and with the detection of a touch event the execution of the filter will be halted as long as the touch condition applies.

Refer to Application note "AZD024 - Graphical Representation of the IIR Filter" for detail regarding the execution of the LTA filter.

8.6 Channel Base

The base value for the counts for both channels in the ATI algorithm can manually be adjusted.

Configuration: Bank1 bit1-0

Base1:Base0: Base value of CS	
Bit	Selection
00	200
01	50
10	100
11	250

The lower the base value, the more gain will be added with compensation, which will result in more sensitivity.

8.7 Data Streaming

The IQS152 has the capability to stream data to a MCU. This provides the designer with the capability to obtain the parameters within the device in order to aid design into applications. Data streaming may further be used by an MCU to control events or further process results obtained from the IQS152. Data streaming is performed as a 1-wire data protocol on one of the output pins (TO0). TO0 is a software open drain pin in data streaming mode, and requires an external pull-up resistor (4k7). Data Streaming can be enabled as indicated below:

Configuration: Bank2 bit5

Streaming: 1-wire data streaming mode	
Bit	Selection
0	Disabled
1	Enabled

When data streaming is enabled data is sent following each charge cycle.



Figure 8.1 illustrates the communication protocol for initialising and sending data with the 1 wire communication protocol.

1. Communications is initiated by a START bit. This bit is defined as a low condition for t_{START}
2. Following the START bit a synchronisation byte ($t_{INIT} = 0xAA$) is sent. This byte is used by the MCU for clock synchronisation.
3. Following t_{INIT} the data bytes will be sent.
4. Each byte sent will be preceded by a START bit and a STOP bit will follow every byte.
5. A STOP bit is indicated by taking pin 7 high. The STOP bit does not have a defined period.

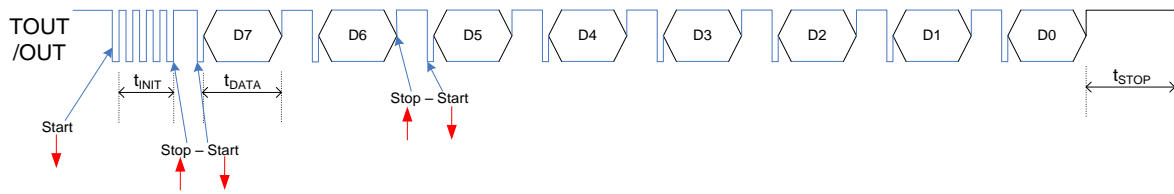

Figure 8.1 IQS152 1-wire data streaming protocol.

8.8 Noise Detect

The IQS152 has advanced immunity to RF noise sources such as GSM cellular telephones, DECT, Bluetooth and WIFI devices. Design guidelines should however be followed to ensure the best noise immunity.

Configuration: Bank2 bit4

ND: Noise Detect

Bit	Selection
0	Disabled
1	Enabled

Notes for layout:

- ⚡ A ground plane should be placed under the IC, except under the Cx lines. All the tracks on the PCB must be kept as short as possible.
- ⚡ The capacitor between V_{DDHI} and GND as well as between V_{REG} and GND, must be placed as close as possible to the IC.
- ⚡ A 100 pF capacitor can be placed in parallel with the 1uF capacitor between V_{DDHI} and GND. Another 100 pF capacitor can be placed in parallel with the 1uF capacitor between V_{REG} and GND.
- ⚡ When the device is too sensitive for a specific application a parasitic capacitor (max 5pF) can be added between the CRX line and CTX.
- ⚡ Proper sense electrode and button design principles must be followed.
- ⚡ Unintentional coupling of sense electrode to ground and other circuitry must be limited by increasing the distance to these sources.
- ⚡ In some instances a ground plane some distance from the device and sense electrode may provide significant

shielding from undesired interference.

When the capacitance between the sense electrode and ground becomes too large the sensitivity of the device may be influenced.

8.9 Power Modes

The IQS152 IC has four power modes specifically designed to reduce current consumption for battery applications.

The power modes are implemented around the occurrence of charge cycle every t_{SAMPLE} seconds. The fewer charge transfer cycles that need to occur per second the lower the power consumption (but decreased response time) will be.

During normal power operation charge cycles are initiated approximately every 27ms. This is referred to as Normal Power Mode (NP). The IQS152 by default be in Boost Power Mode (fastest response rate).

The timings for all the Power Modes are provided in Table 8.1. While in any power mode, the device will zoom to BP whenever the counts indicate a possible proximity or touch event (see Figure 8.2). The device will remain in BP for t_{ZOOM} seconds and then return to the selected power mode. The Zoom function allows reliable detection of events with counts being produced at the BP rate.



Table 8.1 Power Mode timings

Power Mode timing	t _{SAMPLE} (ms)
T _{BP} (default)	9
t _{NP}	27
t _{LP1}	128
t _{LP2}	512

Configuration: Bank2 bit3-2

P _{MODE0} :P _{MODE1} : Power Modes	
Bit	Selection
00	Boost Power Mode (BP)
01	Normal Power Mode (NP)
10	Low Power Mode 1 (LP1)
11	Low Power Mode 2 (LP2)

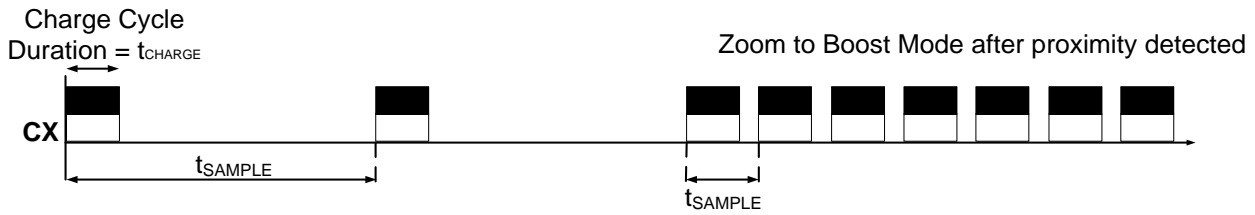

Figure 8.2 LP Modes: Charge cycles

8.10 UI Select

Configuration: Bank2 bit1

UI Select: Dycal enable

Bit	Selection
0	Normal operation
1	Dycal operation

8.11 Logic Output

In standalone mode, the IQS152 can be set to function as active high or low upon proximity and touch detections.

The TO and PO pins only provide a logic level indication (no current source/sink capabilities), thus for example, if LED's are to be switched, the output pins must connect to the gate of a FET (thus only capacitive loads).

The IQS152 is push-pull in both configurations, and does not require external pull-up resistors on its output pins.

Configuration: Bank2 bit0

Logic: Output Logic Select

Bit	Selection
0	Active Low
1	Active High

9 Charge Transfers

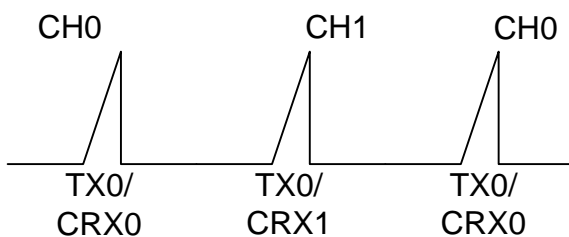

Figure 9.1 Charge Transfer for IQS152.

9.2 Response Rate

When the IC is operating in full running mode (Boost Power – 9ms), a sample of each channel is received at roughly every 18ms. To account for the debounce value (2 samples for touch, up and down) the maximum report rate is estimated as 12 touches per second.



10 Auto Tuning Implementation (ATI)

ATI is a sophisticated technology implemented in the latest generation ProxSense™ devices that optimises the performance of the sensor in a wide range of applications and environmental conditions (refer to application note AZD0027 - Auto Tuning Implementation).

ATI makes adjustments through internal reference capacitors (as required by most other solutions) to obtain optimum performance.

ATI adjusts internal circuitry according to two parameters, the ATI multiplier and the ATI compensation. The ATI multiplier can be viewed as a course adjustment and the ATI compensation as a fine adjustment.

The adjustment of the ATI parameters will result in variations in the counts and sensitivity. Sensitivity can be observed as the change in counts as the result of a fixed change in sensed capacitance. The ATI parameters have been chosen to provide significant overlap. It may therefore be possible to select various combinations of ATI multiplier and ATI compensation settings to obtain the same count values. The sensitivity of the various options may however be different for the same counts.

10.1 Automatic ATI

The IQS152 implements an automatic ATI algorithm. This algorithm automatically adjusts the ATI parameters to optimise the sense electrodes connection to the device.

The device will execute the ATI algorithm whenever the device starts-up and when the counts are not within a predetermined range.

While the Automatic ATI algorithm is in progress this condition will be indicated in the streaming data and proximity and touch events cannot be detected. The device will only briefly remain in this condition and it will be entered only when relatively large shifts in the counts has been detected.

The automatic ATI function aims to maintain a constant count value, regardless of the capacitance of the sense electrode (within the maximum range of the device).

The effects of auto-ATI on the application are the following:

- ⤿ Automatic adjustment of the device configuration and processing parameters for a wide range of PCB and application designs to maintain an optimal configuration for proximity and touch detection.
- ⤿ Automatic tuning of the sense electrodes at start-up to optimise the sensitivity of the application.
- ⤿ Automatic re-tuning when the device detects changes in the sense electrodes capacitance to accommodate a large range of changes in the environment of the application that influences the sense electrodes.
- ⤿ Re-tuning only occurs during device operation when a relatively large sensitivity reduction is detected. This is to ensure smooth operation of the device during operation.
- ⤿ Re-tuning may temporarily influences the normal functioning of the device, but in most instances the effect will be hardly noticeable.
- ⤿ Shortly after the completion of the re-tuning process the sensitivity of Proximity detection may be reduced slightly for a few seconds as internal filters stabilises.

Automatic ATI can be implemented so effectively due to:

- ⤿ Excellent system signal to noise ratio (SNR).
- ⤿ Effective digital signal processing to remove AC and other noise.
- ⤿ The very stable core of the devices.
- ⤿ The built in capability to accommodate a large range of sensing electrodes capacitances.

10.2 Partial ATI

If the ATI Select bit is set (to Partial), the touch threshold for CH1 is the same as for CH0 (see



Section 8.2, CH1 touch threshold is now also set in Bank 0). If the ATI bit is not set (default), CH1 has its own touch threshold. The same applies to the Proximity channel's base value, which is not set in the first two bits of Bank 0 anymore. Instead, the first 5 bits of Bank 0, changes to Multiplier bits (both Sensitivity and Compensation) as follow:

Configuration: Bank1 bit 2-0

Comp2:Comp0: Compensation Multiplier

Bit	Selection
000	0
001	1
010	2
011	3
100	4
101	5
110	6
111	7

Configuration: Bank0 bit1-0

Base1:Base0: Sensitivity Multiplier

Bit	Selection
00	0
01	1
10	2
11	3



11 Electrical Specifications

11.1 Absolute Maximum Specifications

The following absolute maximum parameters are specified for the device:

Exceeding these maximum specifications may cause damage to the device.

⚡ Operating temperature	-40°C to 85°C
⚡ Supply Voltage (VDDHI – GND)	5.5V
⚡ Maximum pin voltage	VDDHI + 0.5V
⚡ Maximum continuous current (for specific Pins)	
⚡ Minimum pin voltage	GND - 0.5V
⚡ Minimum power-on slope	100V/s
⚡ ESD protection	±3kV
⚡ Maximum pin temperature during soldering	
⚡ Maximum body temperature during soldering	

Table 11.1 IQS152 General Operating Conditions

DESCRIPTION	Conditions	PARAMETER	MIN	TYP	MAX	UNIT
Supply voltage ¹		V _{DDHI}	2.95	3.3V	5.50	V
Internal regulator output	2.95 ≤ V _{DDHI} ≤ 5.0	V _{REG}	2.35	2.50	2.65	V
Internal regulator output	2.0 ≤ V _{DDHI} ≤ 2.95	V _{REG}	1.80	V _{DDHI}	V _{DDHI}	V
Boost operating current	3.3V	I _{IQS152_BP}		230		μA
Normal power operating current	3.3V	I _{IQS152_NP}		48		μA
Low power operating current	3.3V	I _{IQS152_LP1}		15		μA
Low power operating current	3.3V	I _{IQS152_LP2}		6.5		μA

Table 11.2 Start-up and shut-down slope Characteristics

DESCRIPTION	Conditions	PARAMETER	MIN	MAX	UNIT
POR	V _{DDHI} Slope ≥ 100V/s	POR	0.92	2.3	V
BOD		BOD	1	1.54	V

¹ For loads smaller than 1pF (between Tx and Rx), an external regulator is required, with input ripple suggested below 50mV.



Table 11.3 POUT and TOUT Characteristics

Symbol	Description	I _{SOURCE} (mA)	Conditions	MIN	TYP	MAX	UNIT
V _{OH}	Output High voltage	<1	V _{DDHI} = 5V		5		V
		<1	V _{DDHI} = 3V		3		
Symbol	Description	I _{SINK} (mA)	Conditions	MIN	TYP	MAX	UNIT
V _{OL}	Output Low voltage	<1	V _{DDHI} = 5V		0		V
		<1	V _{DDHI} = 3V		0		

Table 11.4 Initial Touch Times

DESCRIPTION	PARAMETER	MIN	MAX	Unit
BP ¹	Report Rate	27	34	ms
NP	Report Rate	27	52	ms
LP2	Report Rate	27	537	ms

Table 11.5 Repetitive Touch Rates

DESCRIPTION	Conditions	PARAMETER	Sample rate = 5ms	Sample rate = 9ms	UNIT
All power modes	Zoom active	Response Rate ²	>15	>12	Touches/second

¹ Communication and charge frequency to comply with sample rate as reported earlier in this datasheet.

² Debounce of 2 (up and down)



12 Mechanical Dimensions

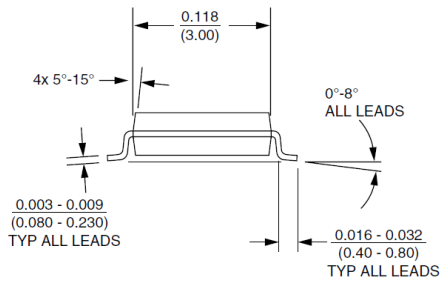

Figure 12.1 MSOP-10 Back view.

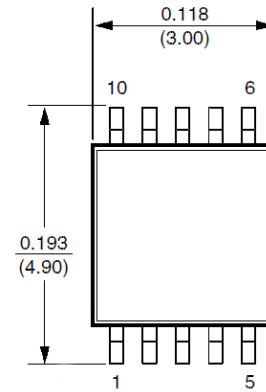

Figure 12.3 MSOP-10 Top view.

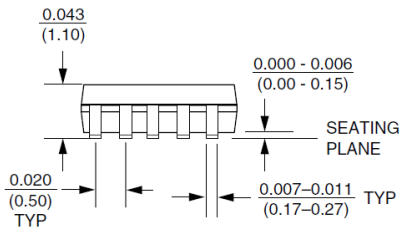

Figure 12.2 MSOP-10 Side view.

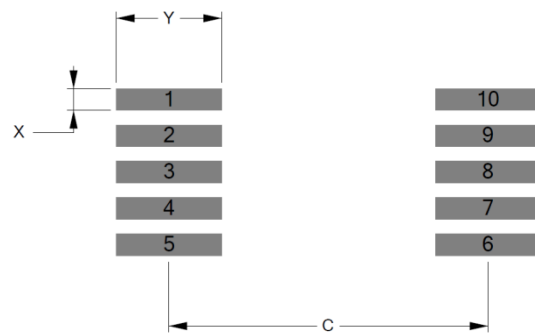

Figure 12.4 MSOP-10 Footprint.

Table 12.1 MSOP-10 Footprint Dimensions from Figure 12.4.

Dimension	[mm]
Pitch	0.50
C	4.40
Y	1.45
X	0.30



13 Device Marking

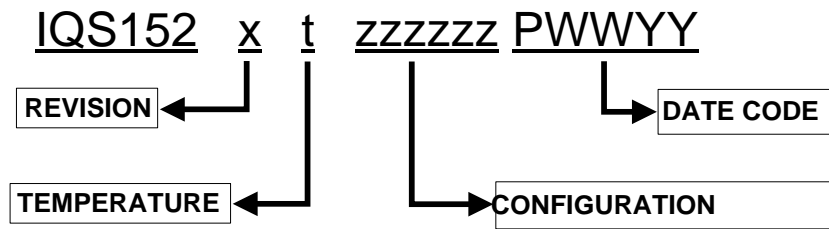

REVISION	x	=	IC Revision Number
TEMPERATURE RANGE	t	=	I -40°C to 85°C (Industrial)
		=	C 0°C to 70°C (Commercial)
IC CONFIGURATION¹	zzzzzz	=	Configuration (Hexadecimal)
DATE CODE	P	=	Package House
	WW	=	Week
	YY	=	Year

14 Ordering Information

Orders will be subject to a MOQ (Minimum Order Quantity) of a full reel. Contact the official distributor for sample quantities. A list of the distributors can be found under the “Distributors” section of www.azoteq.com.

For large orders, Azoteq can provide pre-configured devices.

The Part-number can be generated by using USBProg.exe or the Interactive Part Number generator on the website.

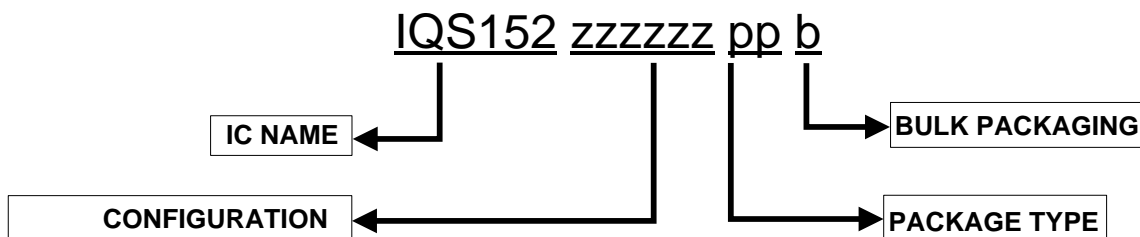

IC NAME	IQS152	=	IQS152
CONFIGURATION	zzzzzz	=	IC Configuration (hexadecimal)
PACKAGE TYPE	MS	=	MSOP-10
BULK PACKAGING	R	=	Reel (4000pcs/reel) – MOQ = 4000pcs
	T	=	Tube (96pcs/tube), Special Order

¹ Configuration marking on the bottom of the IC.



15 Revision History

The limitations for specific revision numbers are described below:

Revision	Device ID	Package Markings	Limitations
0	110F	IQS152 ENG 25110	<ul style="list-style-type: none">• Only active High logic available• PO1 on pin 8• TO1 on pin 9
1	1113	IQS152	<ul style="list-style-type: none">• PO1 on pin 9• TO1 on pin 8



16 Contact Information

PRETORIA OFFICE

Physical Address

160 Witch Hazel Avenue

Hazel Court 1, 1st Floor

Highveld Techno Park

Centurion, Gauteng

Republic of South Africa

Tel: +27 12 665 2880

Fax: +27 12 665 2883

Postal Address

PO Box 16767

Lyttelton

0140

Republic of South Africa

PAARL OFFICE

Physical Address

109 Main Street

Paarl

7646

Western Cape

Republic of South Africa

Tel: +27 21 863 0033

Fax: +27 21 863 1512

Postal Address

PO Box 3534

Paarl

7620

Republic of South Africa

The following patents relate to the device or usage of the device: US 6,249,089 B1, US 6,621,225 B2, US 6,650,066 B2, US 6,952,084 B2, US 6,984,900 B1, US 7,084,526 B2, US 7,084,531 B2, US 7,119,459 B2, US 7,265,494 B2, US 7,291,940 B2, US 7,329,970 B2, US 7,336,037 B2, US 7,443,101 B2, US 7,466,040 B2, US 7,498,749 B2, US 7,528,508 B2, US 7,755,219 B2, US 7,772,781, US 7,781,980 B2, EP 1 120 018 B1, EP 1 206 168 B1, EP 1 308 913 B1, EP 1 530 178 B1, ZL 99 8 14357.X, AUS 761094

IQ Switch®, **ProxSense™**, **LightSense™**, **AirButton®** and the **IQ Logo** are trademarks of Azoteq.

The information appearing in this Datasheet is believed to be accurate at the time of publication. However, Azoteq assumes no responsibility arising from the use of the specifications described. The applications mentioned herein are used solely for the purpose of illustration and Azoteq makes no warranty or representation that such applications will be suitable without further modification, nor recommends the use of its products for application that may present a risk to human life due to malfunction or otherwise. Azoteq products are not authorized for use as critical components in life support devices or systems. No licenses to patents are granted, implicitly or otherwise, under any intellectual property rights. Azoteq reserves the right to alter its products without prior notification. For the most up-to-date information, please refer to www.azoteq.com.

WWW.AZOTEQ.COM

ProxSenseSupport@azoteq.com