



IQS132 Datasheet

IQ Switch[®] - ProxSense[®] Series

Minimalist Capacitive Sensor with Compensation for Sensitivity Reducing Objects

The IQS132 ProxSense[®] IC is a fully integrated two channel capacitive contact and proximity sensor with market leading sensitivity and automatic tuning to the sense electrodes. The IQS132 provides a minimalist implementation requiring as few as 2 external components. The device is ready for use in a large range of applications while programming options allow customisation for specialized applications.

Main Features

- ⌚ 2 Channel input device
- ⌚ ATI: Automatic tuning to optimum sensitivity
- ⌚ Supply Voltage 3V to 5.5V with a LP mode of 4uA
- ⌚ Internal voltage regulator and reference capacitor
- ⌚ OTP options:
 - ❖ Direct (logic level) and serial data output
 - ❖ 8 Power Modes (4µA min)
 - ❖ Proximity & Touch Thresholds
 - ❖ Output Active High and Active Low (open drain)
- ⌚ Large proximity detection range
- ⌚ Automatic drift compensation
- ⌚ Development and Programming tools available (VisualProxSense and USBProg)
- ⌚ Small outline SO-8 package

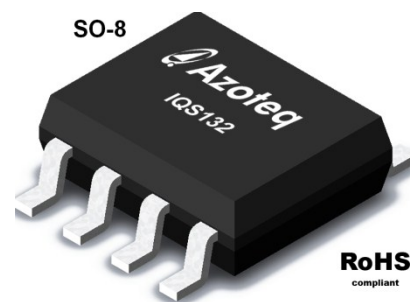

SO-8
Representations only,
not actual markings

Applications

- ⌚ Gesture recognition
- ⌚ White goods and appliances
- ⌚ Remote Controls
- ⌚ Office equipment, toys, sanitary ware
- ⌚ Flame proof, hazardous environment Human Interface Devices
- ⌚ Proximity detection that enables backlighting activation (Patented)
- ⌚ Wake-up from standby applications
- ⌚ Replacement for electromechanical switches
- ⌚ GUI trigger on proximity detection.

Available options

T _A	SO-8
-40°C to 85°C	IQS132
-40°C to 85°C	IQS132Z



Functional Overview

1 Introduction

The IQS132 is a two channel capacitive proximity and touch sensor featuring internal voltage regulator and reference capacitor (C_s).

The device has two dedicated pins for the connection of the sense electrodes (C_x). Output pins for proximity (PROX) and contact detection (TOUCH) on the POUT and TOUT pins. The output pins can also be configured for serial data streaming option on TOUT0.

The devices automatically track slow varying environmental changes via various filters, detect noise and has an automatic Auto Tuning Implementation (ATI) to tune the device for optimal sensitivity.

1.1 Pin-outs

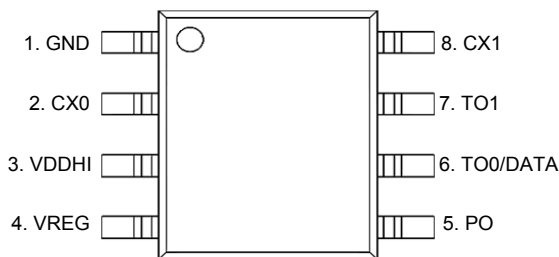

Figure 1.1 IQS132 Pin-outs SO-8.

Table 1.1 IQS132 Pin-outs

Pin	IQS132 SO8	Function
1	GND	Ground
2	CX0	Sense Electrode
3	VDDHI	Power
4	VREG	Regulated Output
5	PO/RF	Proximity Output / Input for noise detect antenna
6	TO0/DATA	Touch Output/Data Output
7	TO1	Touch Output
8	CX1	Sense Electrode

1.2 Applicability

All specifications, except where specifically mentioned otherwise, provided by this datasheet are applicable to the following ranges:

- Temperature -40C to +85C
- Supply voltage (V_{DDHI}) 3V to 5.5V

2 Analogue Functionality

The analogue circuitry measures the capacitance of the sense electrodes attached to the C_x pins through a charge transfer process that is periodically initiated by the digital circuitry. The measuring process is referred to as a conversion and consists of the discharging of C_s and C_x , the charging of C_x and then a series of charge transfers from C_x to C_s until a trip voltage is reached. The number of charge transfers required to reach the trip voltage is referred to as the count value (CS).

The capacitance measurement circuitry makes use of an internal C_s and voltage reference (V_{REF}).

The analogue circuitry further provides functionality for:

- Power on reset (POR) detection.



- ☞ Brown out detection (BOD).

3 Digital Functionality

The digital processing functionality is responsible for:

- ☞ Device configuration from OTP settings after POR.
- ☞ Management of BOD and WDT events.
- ☞ Initiation of conversions at the selected rate.
- ☞ Processing of CS and execution of

algorithms.

- ☞ Monitoring and automatic execution of the ATI algorithm.
- ☞ Signal processing and digital filtering.
- ☞ Detection of PROX and TOUCH events.
- ☞ Managing outputs of the device.
- ☞ Managing serial communications.
- ☞ Manage programming of OTP options.

Detailed Description

4 Reference Design

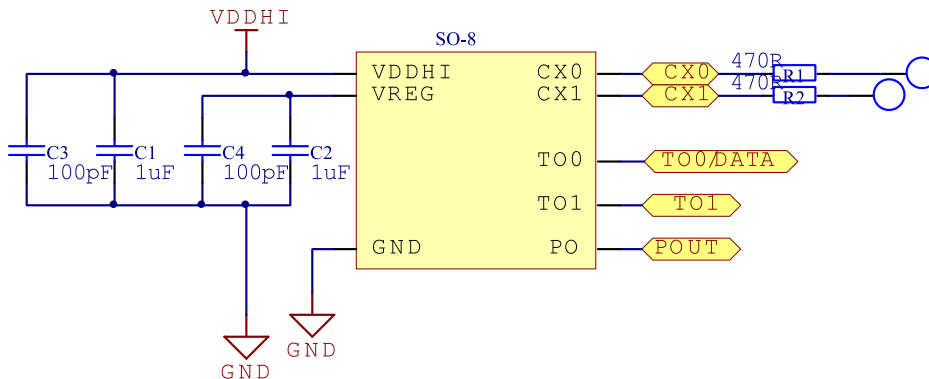

- ☞ Use C3 and C4 for added RF immunity.
- ☞ External pull-up on TOUT1 required when used in Data streaming mode.
- ☞ Place C1-C4 as close as possible to the IC, connected to good GND.
- ☞ TO0 & TO1 is default in active low (open drain)

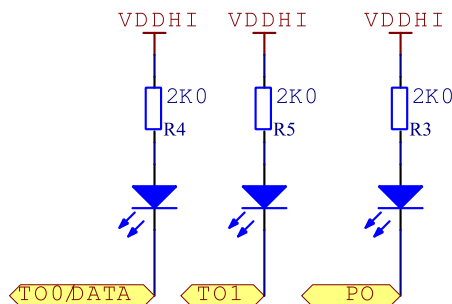

- ☞ LEDs used in active low mode
- ☞ Use R3-R5 for current limiting on I/Os

Figure 4.1 Reference Design Output in active low (optional indicators).



5 High Sensitivity

Through patented design and advanced signal processing, the device is able to provide extremely high sensitivity to detect Proximity. This enables designs that can detect proximities at distances that cannot be equalled by most other products. When the device is used in environments where noise or ground effects exist that lower the sensitivity, a reduced proximity threshold is proposed to ensure reliable functioning of the sensor.

6 User Options

The IQS132 provides One Time Programmable (OTP) user options (each option can be modified only once). The device is fully functional in the default (unconfigured) state. OTP options are intended for specific applications.

The configuration of the device can be done on packaged devices or in-circuit. In-circuit configuration may be limited by values of external components chosen.

6.1 Configuring of Devices

Azoteq offers a Configuration Tool (CTxxx) and accompanying software (USBProg.exe) that can be used to program the OTP user options for prototyping purposes. More details regarding the configuration of the device with the USBProg program is explained by application note: "AZD007 – USBProg Overview" which can be found on the Azoteq website.

Alternative programming solutions of the IQS132 also exists. For further enquiries regarding this matter please contact Azoteq at ProxSenseSupport@azoteq.com or the local distributor.



Table 6-1: User Selectable Configuration Options: Bank 0

P_{MODE2}	P_{MODE1}	P_{MODE0}	T_{THR2}	T_{THR1}	T_{THR0}	P_{THR1}	P_{THR0}
-------------	-------------	-------------	------------	------------	------------	------------	------------

bit 7

bit 0

Bank 0: bit 7-5 **P_{MODE2} : P_{MODE0} :**Power Modes

Section 7.3

- 000 = Boost Power Mode
- 001 = Normal Power Mode
- 010 = Low Power Mode 1
- 011 = Low Power Mode 2
- 100 = Low Power Mode 3
- 101 = Low Power Mode 4
- 110 = Low Power Mode 5
- 111 = Low Power Mode 6

Bank 0: bit 4-2 **T_{THR2} : T_{THR0} :** Touch Thresholds on CH1

Section 7.2

- 000 = 4/64
- 001 = 1/64
- 010 = 2/64
- 011 = 8/64
- 100 = 12/64
- 101 = 16/64
- 110 = 24/64
- 111 = 32/64

Bank 0: bit 1-0 **P_{THR1} : P_{THR0} :**Proximity Thresholds

Section 7.1

- 00 = 2 (4 for IQS132Z)
- 01 = 4 (2 for IQS132Z)
- 10 = 8
- 11 = 16



Table 6-2: User Selectable Configuration Options: Bank 1

t_{HALT1}	t_{HALT0}	ATI	T_{THR2}	T_{THR1}	T_{THR0}	BASE1	BASE0
--------------------	--------------------	-----	-------------------	-------------------	-------------------	-------	-------

bit 7

bit 0

Bank 1: bit 7-6	$t_{\text{HALT0}}:t_{\text{HALT1}}$: Halt time of Long Term Average							Section 7.5
	00 = 20 seconds							
	01 = 40 seconds							
	10 = Always							
	11 = Always (Prox on 40)							
Bank 1: bit 5	ATI: ATI Select							Section 10.2
	0 = Full							
	1 = Partial							
Bank 1: bit 4-2	$T_{\text{TH2}}:T_{\text{TH0}}$: Touch Thresholds on CH2							Section 7.2 & Section 10.2
	000 = 4/64							
	001 = 1/64							
	010 = 2/64							
	011 = 8/64							
	100 = 12/64							
	101 = 16/64							
	110 = 24/64							
	111 = 32/64							
Bank 1: bit 1-0	BASE1:BASE0: Proximity CH Base Value							Section 7.4
	00 = 200							
	01 = 50							
	10 = 100							
	11 = 250							



Table 6-3: User Selectable Configuration Options: Bank 2

		STREAMING	ND LEVEL	ND		CX1 Block	LOGIC
--	--	-----------	----------	----	--	-----------	-------

bit 7							bit 0
	Bank 2: bit 5	STREAMING: 1-wire streaming mode			Section 9.1		
		0 = Disabled					
		1 = Enabled					
	Bank 2: bit 4	ND LEVEL: Sets ND level			Section 7.8		
		0 = 50mV					
		1 = 25mV					
	Bank 2: bit 3	ND: Noise Detect			Section 7.8		
		0 = Disabled					
		1 = Enabled					
	Bank 2: bit1	CX1 Block: Guard channel enable			Section 7.7		
		0 = Disabled					
		1 = Enabled					
	Bank 2: bit0	LOGIC: Output logic select -			Section 7.6		
		0 = Active Low (Software open drain)					
		1 = Active High					



7 Description of User Options

This section describes the individual user programmable options of the IQS132 in more detail.

A number of standard device configurations are available (refer to Chapter 6). Azoteq can supply pre-configured devices for large quantities.

7.1 Adjustable Proximity Threshold

The IQS132 has 4 proximity threshold settings. The proximity threshold is selected by the designer to obtain the desired sensitivity and noise immunity. The proximity event is triggered based on the selected proximity threshold; the CS and LTA (Long Term Average). The threshold is expressed in terms of counts; the same as CS.

The IQS132Z start with a proximity threshold of the $P_{TH} + 4$ for 15 seconds (as well as $P_{TH} + 4$ when in zoom mode if one of the LP selections are used) from a cold start. After 15 seconds, the proximity threshold will adjust to the value selected by the OTP option.

Configuration: Bank0 bit1-0

PTHR0:PTHR1: Proximity Thresholds

Bit	Selection
00	2 (Most sensitive, 4 for IQS132Z)
01	4 (2 for IQS132Z)
10	8
11	16 (Least sensitive)

A proximity event is identified when for at least 4 consecutive samples the following equation holds:

$$P_{TH} \leq LTA - CS$$

Where LTA is the Long Term Average

7.2 Adjustable Touch Thresholds

The IQS132 has 8 touch threshold settings. The touch threshold is selected by the designer to obtain the desired touch

sensitivity. The touch threshold is expressed as a fraction of the LTA as follows:

$$T_{TH} = \text{Selected Touch Threshold} \times LTA$$

Where LTA is the Long Term Average

The touch event is triggered based on T_{TH} , CS and LTA. A touch event is identified when for at least 2 consecutive samples the following equation holds:

$$T_{TH} \leq LTA - CS$$

With lower average CS (therefore lower LTA) values the touch threshold will be lower and vice versa.

Configuration: Bank0 bit4-2

TTHR0:TTHR2: Touch Thresholds

Bit	Selection
000	4/64
001	1/64 (Most sensitive)
010	2/64
011	8/64
100	12/64
101	16/64
110	24/64
111	32/64 (Least sensitive)

The touch threshold for CH2 is only set separately from CH1 when Partial ATI is selected.

7.3 LP modes

The IQS132 IC has eight power modes specifically designed to reduce current consumption for battery applications.

The power modes are basically implemented around the occurrence of charge cycle every t_{SAMPLE} seconds (refer to Table 7.1). The fewer charge transfer cycles that need to occur per second the lower the power consumption (but decreased response time) will be.

During normal operation charge cycles are initiated approximately every 50ms. This is referred to as Normal Power Mode (NP). The



IQS132 by default charges in Boost Power Mode (BP).

The timings for all the Power Modes are provided in the table below. While in any power mode the device will zoom to BP whenever a count value (CS) indicates a possible proximity or touch event. The device will remain in BP for t_{ZOOM} seconds and then return to the selected power mode. The Zoom function allows reliable detection of events (with the shortest response time) with counts being produced at the BP rate.

Table 7.1 Power Mode timings

Power Mode timing	t_{SAMPLE} (ms)
t_{BP} (default)	5
t_{NP}	50
t_{LP1}	256
t_{LP2}	512
t_{LP3}	768
t_{LP4}	1024
t_{LP5}	1536
t_{LP6}	2048

Configuration: Bank0 bit7-5

PMODE0:PMODE1: Power Modes	
Bit	Selection
000	Boost Power Mode (BP)
001	Normal Power Mode (NP)
010	Low Power Mode 1 (LP1)
011	Low Power Mode 2 (LP2)
100	Low Power Mode 3 (LP3)
101	Low Power Mode 4 (LP4)
110	Low Power Mode 5 (LP5)
111	Low Power Mode 6 (LP6)

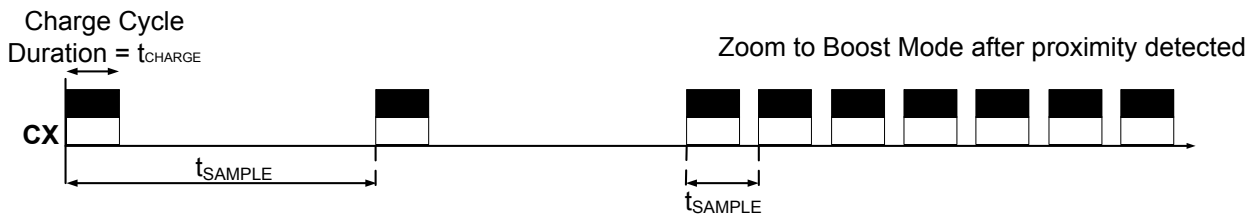

Figure 7.1 LP Modes: Charge cycles

7.4 ATI Base Value

The sensitivity gain of the Proximity channel can be set by adjusting the Base Value of the ATI algorithm. Decreasing the base from 200 to 150 or even 50 will increase the sensitivity and vice versa. By decreasing the base value, the analog gain from the sensor is increased.

Configuration: Bank1 bit1-0

BASE1:BASE0: Proximity Base Value

Bit	Selection
00	200
01	50
10	100
11	250

7.5 THALT

The IQS132 devices employ various signal processing functions that includes the execution of various filters as described below.

7.5.1 Long Term Average (LTA)

Capacitive touch devices detect changes in capacitance that are not always related to the intended proximity or touch of a human. This is a result of changes in the environment of the sense plate and other factors. These changes need to be compensated for in various manners in order to reliably detect touch events and especially to detect proximity events. One mechanism the IQS132 employs is the use of a Long Term Averaging filter (IIR type filter) which tracks slow changes in the environment (expressed as changes in the counts). The result of this filter is a Long Term Average (LTA) value that forms a dynamic reference used for various functions such as identification of proximity and touch events.

The LTA is calculated from the counts (CS). The filter only executes while no proximity or touch event is detected to ensure compensation only for environmental changes. However there may be instances where sudden changes in the environment or changes in the environment while a proximity or touch event has been detected cause the CS to drift away from the LTA. To compensate for these situations a Halt Timer (t_{HALT}) has been defined.

The Halt Timer is started when a proximity or touch event occurs (for the 132Z, both channels' filters halt on a proximity event) and when it expires the LTA filter is recalibrated. Recalibration causes $LTA < CS$, thus the disappearance of proximity or touch events.

The designer needs to select a Halt Timer value to best accommodate the required application.

Configuration: Bank1 bit7-6

t_{HALT1}:t_{HALT0}: Halt time of Long Term Average

Bit	Selection
00	20 seconds
01	40 seconds
10	Never
11	ALWAYS (Prox on 40 seconds)

Notes:

- ⚡ With the Never (bit selection "10") option, the filter will not halt when any proximity or touch condition occurs.
- ⚡ With the 'ALWAYS' (bit selection "11") option and the detection of a proximity event the execution of the filter will be halted for only 40 seconds and with the detection of a touch event the execution of the filter will be halted as long as the touch condition applies.

Refer to Application note "AZD024 - Graphical Representation of the IIR Filter" for



detail regarding the execution of the LTA filter.

7.6 Logic Output

The IQS132 can be set to sink or source current in stand-alone mode, by setting the logic output active high or active low.

Configuration: Bank2 bit0

Logic: Output Logic Select	
Bit	Selection
0	Active Low
1	Active High

7.7 CX1 Block

The IQS132 can set channel 1 as a guard channel. Enabling this feature will result in the IQS132 blocking the touch outputs while a touch event is detected on CX1. If CX0 already has a touch active, it will be cleared.

Configuration: Bank2 bit1

CX1 Block:	
Bit	Selection
0	Disabled
1	Enabled

7.8 Noise Detection

The IQS132 has advanced immunity to RF noise sources such as GSM cellular telephones, DECT, Bluetooth and WIFI devices. Design guidelines should however be followed to ensure the best noise immunity.

Configuration: Bank2 bit3

ND: Noise Detect	
Bit	Selection
0	Disabled
1	Enabled

Notes for layout:

- ☞ Place the Sensor IC as close as possible to the sense electrodes.
- ☞ A ground plane should be placed under the IC, except under the Cx lines.
- ☞ All the tracks on the PCB must be kept as short as possible.
- ☞ The capacitor between V_{DDHI} and GND as well as between V_{REF} and GND, must be placed as close as possible to the IC.

- ☞ A 100 pF capacitor can be placed in parallel with the 1uF capacitor between V_{DDHI} and GND. Another 100 pF capacitor can be placed in parallel with the 1uF capacitor between V_{REF} and GND.
- ☞ When the device is too sensitive for a specific application a parasitic capacitor (max 5pF) can be added between the Cx line and ground.
- ☞ Proper sense electrode and button design principles must be followed.
- ☞ Unintentional coupling of sense electrode to ground and other circuitry must be limited by increasing the distance to these sources.
- ☞ In some instances a ground plane some distance from the device and sense electrode may provide significant shielding from undesired interference.

When the capacitance between the sense electrode and ground becomes too large the sensitivity of the device may be influenced. For more guidelines on proper layout, please see the application note: "AZD008 - Design Guidelines for Touch Pads" on the Azoteq webpage www.azoteq.com.

8 Charge Transfers

The IQS132 samples in 3 timeslots, with one internal Cs capacitor. The charge sequence is shown in Figure 8.1, where CH0 is the Prox channel, and charges before each of the 2 input channels. CH0 is realised by connecting both touch electrodes with internal switches. Therefore: CH0 is a distributed electrode formed by the 2 touch electrodes.

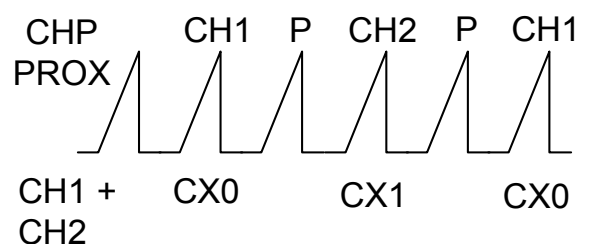

Figure 8.1 Charge Transfer for IQS132.

9 Data Streaming

The IQS132 has the capability to stream data to a MCU. This provides the designer with the capability to obtain the parameters within the device in order to aid design and debugging into applications. Data streaming may further be used by an MCU to control events or further process results obtained from the IQS132. Data streaming is performed as a 1-wire data protocol on one of the output pins (TOU0). The function of this pin is therefore lost when the device is put in streaming mode. Data Streaming can be enabled as indicated below:

9.1 Entering Data Streaming Mode

Configuration: Bank2 bit5

STREAMING: 1-wire data streaming mode

Bit	Selection
0	Disabled
1	Enabled

9.2 Data Streaming Protocol

When data streaming is enabled data is sent following each charge cycle.

Figure 9.1 illustrates the communication protocol for initialising and sending data with the 1 wire communication protocol.

1. Communications is initiated by a START bit. This bit is defined as a low condition for t_{START}
2. Following the START bit a synchronisation byte ($t_{INIT} = 0xAA$) is sent. This byte is used by the MCU for clock synchronisation.
3. Following t_{INIT} the data bytes will be sent. With short data streaming mode enabled, 3 bytes of data will be sent, else 8 bytes will be sent after each charge cycle.
4. Each byte sent will be preceded by a START bit and a STOP bit will follow every byte.
5. A STOP bit is indicated by taking pin 7 high. The STOP bit does not have a defined period.

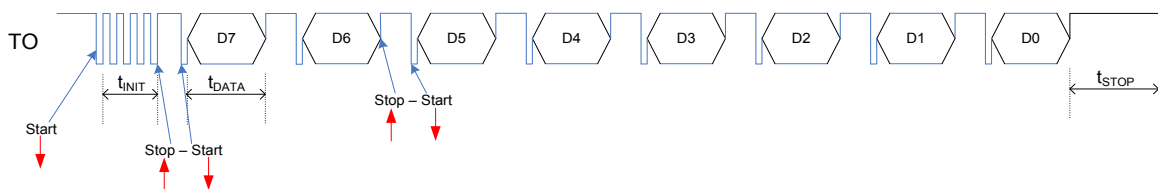

Figure 9.1 Serial data streaming: 1-wire streaming (Debug Mode)



Table 9.1 Byte Definitions for Data Streaming Mode

Byte	Bit	Value
0	7:0	CS High byte
1	15:8	CS Low byte
2	23:16	LTA High byte
3	31:24	LTA Low byte
4	39	ATI busy
	38	RF Noise Detect
	37	Zoom active
	36	LP active
	35	Not used (always 0)
	34	Proximity event
	33	CH Indication(1)
5	32	CH Indication(0)
	47	Not Used
	46	Not Used
	45	Compensation (5)
	44	Compensation (4)
	43	Compensation (3)
	42	Compensation (2)
41	Compensation (1)	

6	40	Compensation (0)
	55	Not Used
	54	Not Used
	53	Not Used
	52	Multiplier (4)
	51	Multiplier (3)
	50	Multiplier (2)
7	49	Multiplier (1)
	48	Multiplier (0)
	63	Not Used
	62	Not Used
	61	Not Used
	60	Not Used
	59	Not Used
58	Touch CH 2	
57	Touch CH 1	
56	Not Used	

In the 4th byte, the channel indication is represented as:

t_{HALT1} : t_{HALT0} :	Halt time of Long Term Average
00	CH P (distributed proximity channel)
01	CH 0 (First touch channel)
10	CH 1 (Second Touch channel)

10 Auto Tuning Implementation (ATI)

ATI is a sophisticated technology implemented in the latest generation ProxSense® devices that optimises the performance of the sensor in a wide range of applications and environmental conditions (refer to application note AZD0027 - Auto Tuning Implementation).

ATI makes adjustments through internal reference capacitors to obtain optimum performance.

ATI adjusts internal circuitry according to two parameters, the ATI multiplier and the ATI compensation. The ATI multiplier can be

viewed as a course adjustment and the ATI compensation as a fine adjustment.

The adjustment of the ATI parameters will result in variations in the counts and sensitivity. Sensitivity can be observed as the change in counts as the result of a fixed change in sensed capacitance. The ATI parameters have been chosen to provide significant overlap. It may therefore be possible to select various combinations of ATI multiplier and ATI compensation settings to obtain the same count values. The sensitivity of the various options may however be different for the same counts.



10.1 Automatic ATI

The IQS132 implements an automatic ATI algorithm. This algorithm automatically adjusts the ATI parameters to optimise the sensing electrodes connection to the device.

The device will execute the ATI algorithm whenever the device starts-up and when the counts are not within a predetermined range.

While the Automatic ATI algorithm is in progress this condition will be indicated in the streaming data and proximity and touch events cannot be detected. The device will only briefly remain in this condition and it will be entered only when relatively large shifts in the counts has been detected.

The automatic ATI function aims to maintain a constant count value, regardless of the capacitance of the sense electrode (within the maximum range of the device).

The effects of auto-ATI on the application are the following:

- ⌚ Automatic adjustment of the device configuration and processing parameters for a wide range of PCB and application designs to maintain an optimal configuration for proximity and touch detection.
- ⌚ Automatic tuning of the sense electrodes at start-up to optimise the sensitivity of the application.
- ⌚ Automatic re-tuning when the device detects changes in the sensing electrodes capacitance to accommodate a large range of changes in the environment of the application that influences the sensing electrodes.
- ⌚ Re-tuning only occurs during device operation when a relatively large sensitivity reduction is detected. This is to ensure smooth operation of the device during operation.
- ⌚ Re-tuning may temporarily influences the normal functioning of the device, but in most instances the effect will be hardly noticeable.
- ⌚ Shortly after the completion of the re-tuning process the sensitivity of Proximity detection may be reduced slightly for a

few seconds as internal filters stabilises.

Automatic ATI can be implemented so effectively due to:

- ⌚ Excellent system signal to noise ratio (SNR).
- ⌚ Effective digital signal processing to remove AC and other noise.
- ⌚ The very stable core of the devices.
- ⌚ The built in capability to accommodate a large range of sensing electrode capacitances.

10.2 Partial ATI

If the ATI Select bit is set (to Partial), the touch threshold for CH1 is the same as for CH0 (see Section 7.4, CH1 touch threshold is now also set in Bank 0). If the ATI bit is not set (default), CH1 has its own touch threshold (set in Bank 1). The same applies to the Proximity channel's base value, which is not set in the first two bits of Bank 0 anymore. Instead, the first 5 bits of Bank 0, changes to Multiplier bits (both Sensitivity and Compensation) as follow:

Configuration: Bank1 bit 2-0

Comp2:Comp0: Compensation Multiplier

Bit	Selection
000	0
001	1
010	2
011	3
100	4
101	5
110	6
111	7

Configuration: Bank0 bit1-0

Base1:Base0: Sensitivity Multiplier

Bit	Selection
00	0
01	1
10	2
11	3



11 Electrical Specifications

Absolute Maximum Specifications

The following absolute maximum parameters are specified for the device:

Exceeding these maximum specifications may cause damage to the device.

⌚ Operating temperature	-40°C to 85°C
⌚ Supply Voltage (VDDHI – GND)	5.5V
⌚ Maximum pin voltage	VDDHI + 0.5V
⌚ Maximum continuous current (for specific Pins)	
⌚ Minimum pin voltage	GND - 0.5V
⌚ Minimum power-on slope	100V/s
⌚ ESD protection	±3kV
⌚ Maximum pin temperature during soldering	
⌚ Maximum body temperature during soldering	

Table 11.1 IQS132 General Operating Conditions

DESCRIPTION	Conditions	PARAMETER	MIN	TYP	MAX	UNIT
Supply voltage		V _{DDHI}	2.95		5.50	V
Internal regulator output	2.95 ≤ V _{DDHI} ≤ 5.5	V _{REG}	2.35	2.50	2.65	V
Boost operating current	3.3V, BP	I _{IQS132_BP}		210		μA
Normal power operating current	3.3V, NP	I _{IQS132_NP}		17.5		μA
Low power operating current	3.3V, LP1	I _{IQS132_LP1}		6.2		μA
Low power operating current	3.3V, LP2	I _{IQS132_LP2}		4.8		μA
Low power operating current	3.3V, LP3	I _{IQS132_LP3}		4.3		μA
Low power operating current	3.3V, LP4	I _{IQS132_LP4}		4		μA
Low power operating current	3.3V, LP5	I _{IQS132_LP5}		3.8		μA
Low power operating current	3.3V, LP6	I _{IQS132_LP6}		<3.5		μA

Table 11.2 IQS132Z General Operating Conditions

DESCRIPTION	Conditions	PARAMETER	MIN	TYP	MAX	UNIT
Supply voltage		V _{DDHI}	2.95		5.50	V
Internal regulator output	2.95 ≤ V _{DDHI} ≤ 5.0	V _{REG}	2.35	2.50	2.65	V



DESCRIPTION	Conditions	PARAMETER	MIN	TYP	MAX	UNIT
Internal regulator output	$2.0 \leq V_{DDHI} \leq 2.95$	V_{REG}	1.80	V_{DDHI}	V_{DDHI}	V
Boost operating current	3.3V	$I_{IQS132Z_BP}$		210		μA
Normal power operating current	3.3V	$I_{IQS132Z_NP}$		17.5		μA
Low power operating current	3.3V	$I_{IQS132Z_LP1}$		6.2		μA
Low power operating current	3.3V	$I_{IQS132Z_LP2}$		4.8		μA
Low power operating current	3.3V	$I_{IQS132Z_LP3}$		4.3		μA
Low power operating current	3.3V	$I_{IQS132Z_LP4}$		4		μA
Low power operating current	3.3V	$I_{IQS132Z_LP5}$		3.8		μA
Low power operating current	3.3V	$I_{IQS132Z_LP6}$		<3.5		μA

Table 11.3 Start-up and shut-down slope Characteristics

DESCRIPTION	Conditions	PARAMETER	MIN	MAX	UNIT
POR	V_{DDHI} Slope $\geq 100V/s$	POR	0.92	2.3	V
BOD		BOD	1	1.54	V



Table 11.4 POUT and TOUT Characteristics

Symbol	Description	I _{SOURCE} (mA)	Conditions	MIN	TYP	MAX	UNIT
V _{OH}	Output High voltage	16.5mA	V _{DDHI} = 5V		4.72		V
		9.8mA	V _{DDHI} = 3V		2.8		
Symbol	Description	I _{SINK} (mA)	Conditions	MIN	TYP	MAX	UNIT
V _{OL}	Output Low voltage	16mA	V _{DDHI} = 5V		0.48		V
		9mA	V _{DDHI} = 3V		0.36		

Table 11.5 Initial Touch Times

DESCRIPTION	PARAMETER	MIN	MAX	Unit
BP ¹	Report Rate	36	61	ms
NP	Report Rate	45	93	ms
LP6	Report Rate	45	2090	ms

Table 11.6 Repetitive Touch Rates

DESCRIPTION	Conditions	PARAMETER	Sample rate = 5ms	Sample rate = 9ms	UNIT
All power modes	Zoom active	Response Rate ²	>15	>6.5	Touches/second

¹ Communication and charge frequency to comply with sample rate as reported earlier in this datasheet.

² Debounce of 2 (up and down)



12 Mechanical Dimensions

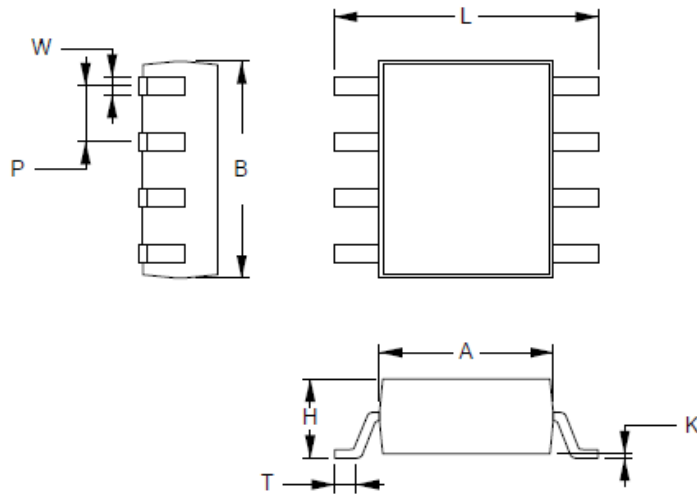

Figure 12.1 SO-8 Package view.

Table 12.1 SO-8 Package Dimensions from Figure 12.1.

Dimension	[mm]
A_{\min}	3.75
A_{\max}	4.15
B_{\min}	4.73
B_{\max}	5.13
H_{\max}	1.8
K_{\min}	0.1
L_{\min}	5.7
L_{\max}	6.3
T_{\min}	0.3
T_{\max}	0.7
Pitch	1.27
W_{\min}	0.31
W_{\max}	0.51

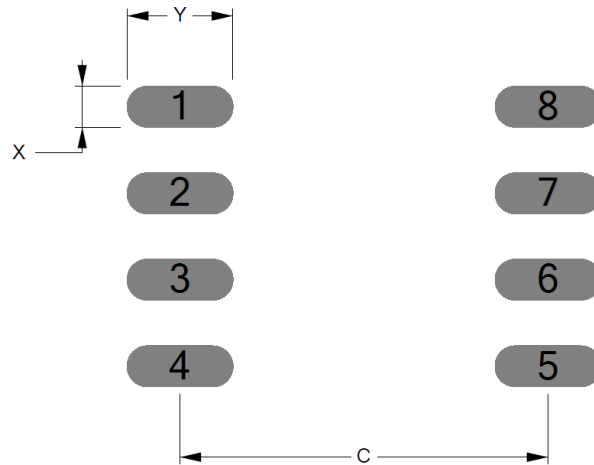

Figure 12.2 SO-8 Footprint Top view.

Table 12.2 SO-8 Footprint Dimensions from Figure 12.2.

Dimension	[mm]
Pitch	1.27
C	5.40
Y	1.55
X	0.60



13 Device Marking

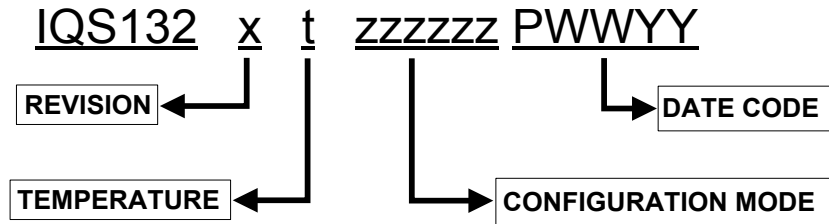

REVISION	x	=	IC Revision Number
TEMPERATURE RANGE	t	=	I -40°C to 85°C (Industrial) C 0°C to 70°C (Commercial)
IC CONFIGURATION¹	zzzzzz	=	Configuration (Hexadecimal)
DATE CODE	P	=	Package House
	WW	=	Week
	YY	=	Year

14 Ordering Information

Orders will be subject to a MOQ (Minimum Order Quantity) of a full reel. Contact the official distributor for sample quantities. A list of the distributors can be found under the “Distributors” section of www.azoteq.com.

For large orders, Azoteq can provide pre-configured devices.

The Part-number can be generated by using USBProg.exe or the Interactive Part Number generator on the website.

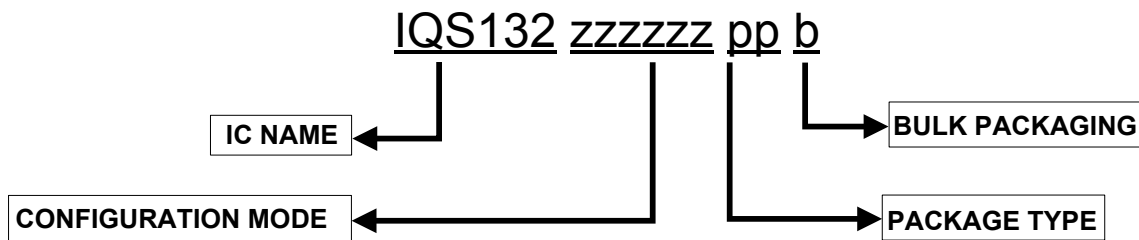

IC NAME	IQS132	=	IQS132
CONFIGURATION	zzzzzz	=	IC Configuration (hexadecimal)
PACKAGE TYPE	SO	=	SO-8
BULK PACKAGING	R	=	Reel (2500pcs/reel) – MOQ = 2500pcs
	T	=	Tube(96pcs/tube, Special Order)

¹ Configuration marking on the bottom of the IC.



15 Revision History

The limitations for specific revision numbers are described below:

Revision	Device ID	Package Markings	Limitations
0	1901	IQS132 ENG	<ul style="list-style-type: none">CX floating between conversions
1	1902 110D	IQS132 25110 or later	<ul style="list-style-type: none">High sensitivity at start up. Suggested $P_{TH} = 8$ (default = 2 may trigger PO on start-up or LP exit in selected applications)
2		IQS 132Z	<ul style="list-style-type: none">Low power limitation, down to sub 8uA only.



16 Contact Information

PRETORIA OFFICE

Physical Address

160 Witch Hazel Avenue

Hazel Court 1, 1st Floor

Highveld Techno Park

Centurion, Gauteng

Republic of South Africa

Tel: +27 12 665 2880

Fax: +27 12 665 2883

Postal Address

PO Box 16767

Lyttelton

0140

Republic of South Africa

PAARL OFFICE

Physical Address

109 Main Street

Paarl

7646

Western Cape

Republic of South Africa

Tel: +27 21 863 0033

Fax: +27 21 863 1512

Postal Address

PO Box 3534

Paarl

7620

Republic of South Africa

The following patents relate to the device or usage of the device: US 6,249,089 B1, US 6,621,225 B2, US 6,650,066 B2, US 6,952,084 B2, US 6,984,900 B1, US 7,084,526 B2, US 7,084,531 B2, US 7,119,459 B2, US 7,265,494 B2, US 7,291,940 B2, US 7,329,970 B2, US 7,336,037 B2, US 7,443,101 B2, US 7,466,040 B2, US 7,498,749 B2, US 7,528,508 B2, US 7,755,219 B2, US 7,772,781, US 7,781,980 B2, EP 1 120 018 B1, EP 1 206 168 B1, EP 1 308 913 B1, EP 1 530 178 B1, ZL 99 8 14357.X, AUS 761094

IQ Switch[®], ProxSense[®], LightSense[™], AirButton[®] and the IQ Logo are trademarks of Azoteq.

The information appearing in this Datasheet is believed to be accurate at the time of publication. However, Azoteq assumes no responsibility arising from the use of the specifications described. The applications mentioned herein are used solely for the purpose of illustration and Azoteq makes no warranty or representation that such applications will be suitable without further modification, nor recommends the use of its products for application that may present a risk to human life due to malfunction or otherwise. Azoteq products are not authorized for use as critical components in life support devices or systems. No licenses to patents are granted, implicitly or otherwise, under any intellectual property rights. Azoteq reserves the right to alter its products without prior notification. For the most up-to-date information, please refer to www.azoteq.com.

WWW.AZOTEQ.COM

ProxSenseSupport@azoteq.com