



IQS132/33/43EV02 Evaluation Kit User Manual

IQ Switch® - ProxSense™ Series

Table of Contents

IQS132/33/43EV02 EVALUATION KIT USER MANUAL	1
TABLE OF CONTENTS	1
1 INTRODUCTION.....	1
2 EV-KIT MAINBOARD.....	1
3 MODULE BOARDS	2
4 REFERENCE DESIGNS	4
5 PCB DESIGN	5

1 Introduction

This user manual describes the operation of the IQS132/33/43EV02 Evaluation Kit. The EV-Kit is manufactured in four parts, consisting of a mainboard, and three separate plug-in module boards. To adjust IC OTP settings, the main board can be interfaced to any personal computer with the Azoteq Configuration Tool (CTxxx), and making the adjustments by means of the USBProg software. The purpose of the IQS132/33/43EV02 EV-Kit is to help application and development engineers in evaluating the IQS132, IQS133 and IQS143 proximity and touch sensors.

the buttons for IQS132 and IQS133

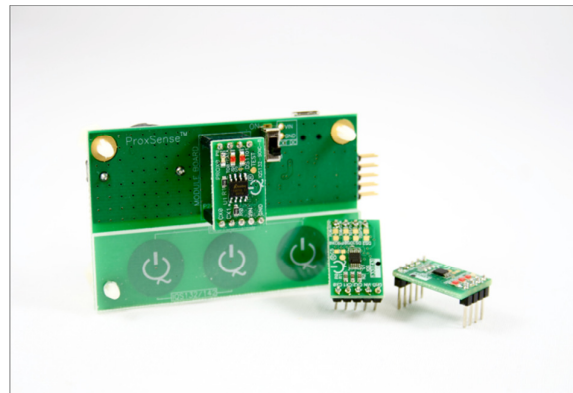

Figure 2.1 IQS132/33/43EV02 Mainboard and controller modules

2 EV-Kit Mainboard

Figure 2.1 illustrates the evaluation kit mainboard and the three supplied controller modules. The mainboard supplies power and other functions to the controller module boards and is easily operated. Simply plug in the desired module board into the mainboard and turn on the mainboard by means of the on/off slide switch. Features included in the EV-Kit mainboard:

- Modular design: Connect one of the supplied IC modules into the mainboard, or wire into a prototype for rapid prototyping
- Reference designs for IQS132, IQS133 and IQS143 with user proximity & touch detection ability
- LEDs to indicate proximity AND contact to

- Can be used in Data Streaming Mode: For details see the IQS132, IQS133 and IQS143 datasheets (EV-KIT requires Azoteq Configuration Tool CT, or Azoteq Data Streamer DS)
- Can be used in Direct mode (IQS132 and IQS133 only): Battery or USB powered
- OTP bits can be programmed on the kit (requires CTxxx)

Figure 2.2 illustrates the bottom view of the EV-Kit mainboard. The EV-Kit is powered by two 3V coin cell batteries in series, which is regulated to 3.3V and supplied to the module board. The EV-Kit mainboard can also draw power from a USB source by means of the



mini-USB connector provided on the mainboard.

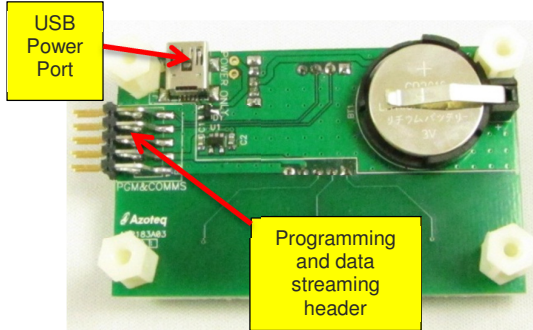

Figure 2.2 Bottom view of EV-Kit mainboard

The mainboard includes a programming and data streaming header as also illustrated in the figure.

The EV-Kit is interfaced to a personal computer for data streaming and programming OTP options, by means of the Azoteq Configuration Tool (CTxxx). For IC programming and visual data streaming please utilize the VisualProxSense and USBProg software, provided on the Azoteq website. (www.azoteq.com).

3 Module Boards

3.1 IQS132 Module board

Figure 3.1 illustrates the IQS132 Module board. Its features include:

- 1 x Proximity indication LED
- 2 x Touch indication LEDs (One for each channel)
- Small and compact PCB layout, which is easily wired to prototype applications

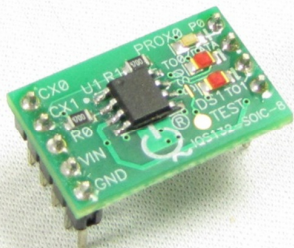

Figure 3.1 IQS132 Module board

Descriptions of the components are given in Table 3.1.

Table 3.1 IQS132 Module board component description

Component	Purpose	Typical value
C1, C2	Power supply decoupling capacitors	1μF, 100pF
C3, C4	Internal regulator decoupling capacitors	1μF, 100pF
R2, R3, R4	LED current limiting resistors	2kΩ
R0, R1	Sense antenna (Cx) series resistors (Added ESD Protection)	470Ω
R5	1-Wire Comms pullup resistor	3.3kΩ

3.2 IQS133 Module Board

Figure 3.2 illustrates the IQS133 Module board. Its features include:

- 1 x Proximity indication LED
- 3 x Touch indication LEDs (One for each channel)
- Small and compact PCB layout, which is easily wired to prototype applications

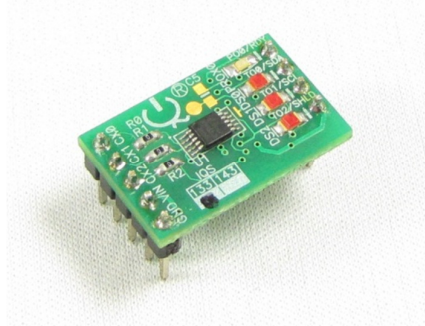

Figure 3.2 IQS133 module board

Descriptions of the IQS133 module board components are given in Table 3.2.

Table 3.2 IQS133 Module board component description

Component	Purpose	Typical value
C1, C2	Power supply decoupling capacitors	1μF, 100pF
C3, C4	Internal regulator decoupling capacitors	1μF, 100pF
R3, R4, R5, R6	LED current limiting resistors	2kΩ
R0, R1, R2	Sense antenna (Cx) series resistors (Added ESD Protection)	470Ω
R8	1-Wire Comms pullup resistor	3.3kΩ

3.3 IQS143 Module Board

Figure 3.3 illustrates the IQS143 Module board. Its features include:

- I²C Communication interface
- Small and compact PCB layout, which can be easily wired to prototype applications

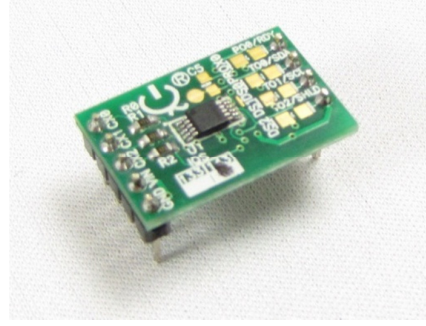

Figure 3.3 Top view of the IQS143 module board

Descriptions of the IQS143 module board components are given in Table 3.3.

Table 3.3 IQS143 Module board component description

Component	Purpose	Typical value
C1, C2	Power supply decoupling capacitors	1μF, 100pF
C3, C4	Internal regulator decoupling capacitors	1μF, 100pF
R7	RDY pullup resistor	10kΩ
R8	SDA pullup resistor	10kΩ
R9	SCL pullup resistor	10kΩ
R10	Shield pullup resistor	10kΩ
R0, R1, R2	Sense antenna (Cx) series resistors (Added ESD Protection)	470Ω

For operation and data visualization, it is necessary to interface the IQS143 module to a personal computer by means of the Azoteq CT200 Configuration Tool. The IQS143 GUI is used to stream and visualize data in real-time.



4 Reference Designs

4.1 IQS132 Reference Design

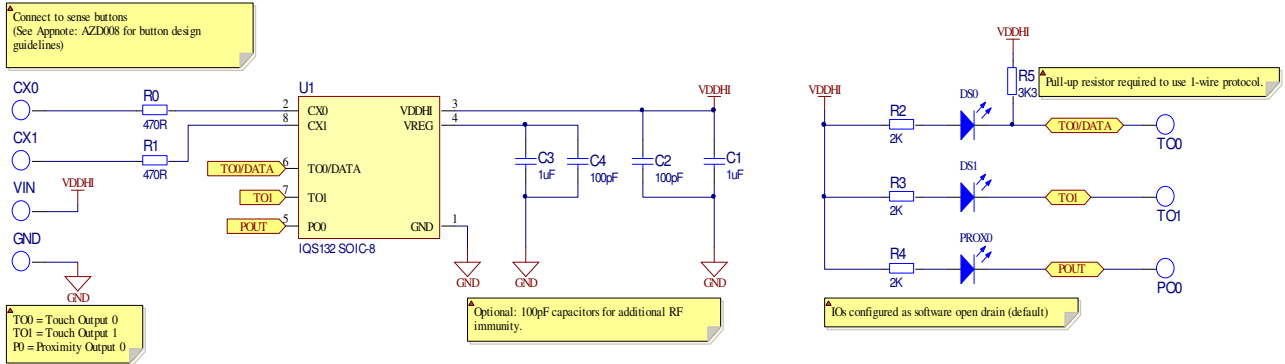

Figure 4.1 IQS132 Reference design

4.2 IQS133 Reference Design

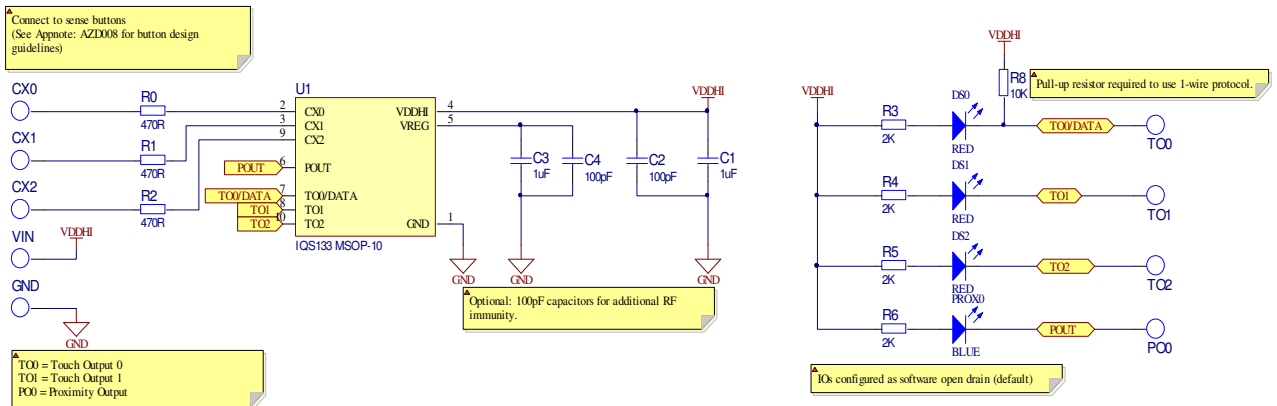

Figure 4.2 IQS133 Reference design

4.3 IQS143 Reference Design

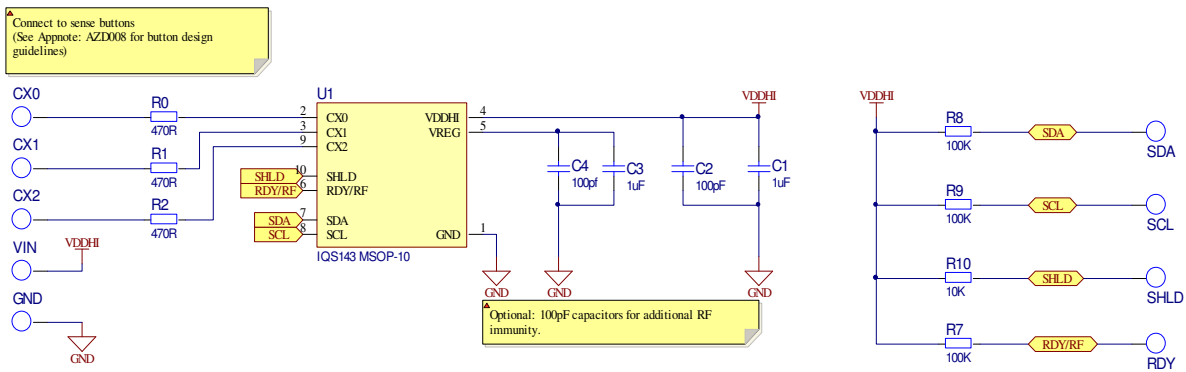

Figure 4.3 IQS143 Reference design



5. PCB Design

5.1 Module PCB Design

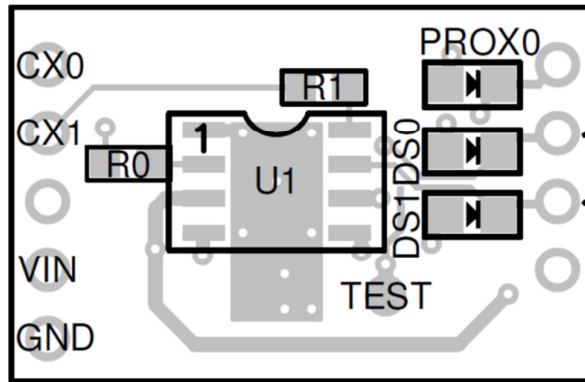

Figure 5.1.1 Top layer component placement

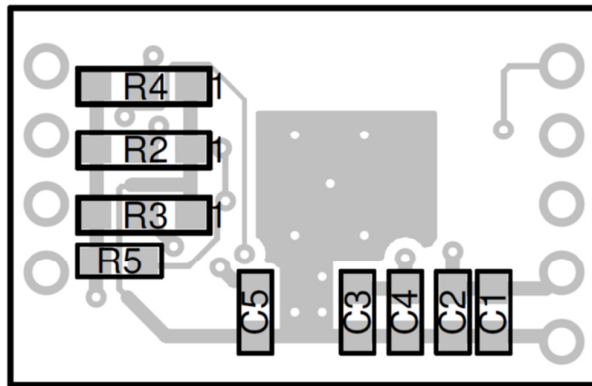

Figure 5.1.2 Bottom layer component placement

4.2 Board Plugin PCB Design for IQS132/33/43 Modules

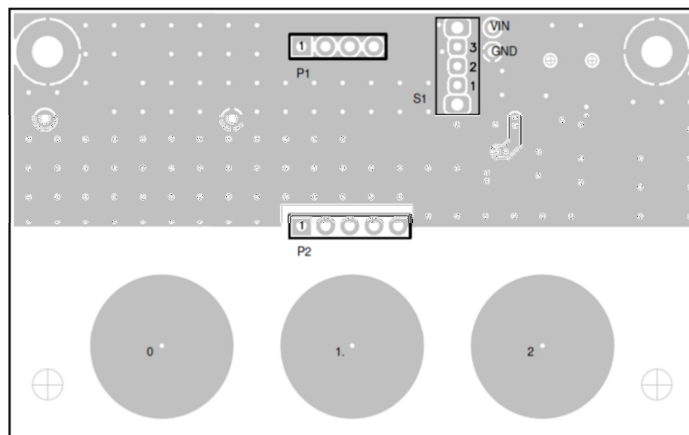

Figure 5.2.1 Top layer component placement

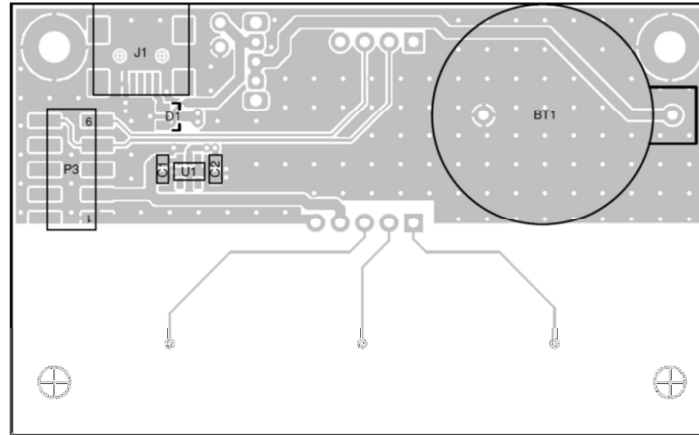

Figure 5.2.2 Bottom layer component placement

The following patents relate to the device or usage of the device: US 6,249,089 B1, US 6,621,225 B2, US 6,650,066 B2, US 6,952,084 B2, US 6,984,900 B1, US 7,084,526 B2, US 7,084,531 B2, US 7,119,459 B2, US 7,265,494 B2, US 7,291,940 B2, US 7,329,970 B2, US 7,336,037 B2, US 7,443,101 B2, US 7,466,040 B2, US 7,498,749 B2, US 7,528,508 B2, US 7,755,219 B2, US7,772,781, US 7,781,980 B2, EP 1 120 018 B1, EP 1 206 168 B1, EP 1 308 913 B1, EP 1 530 178 B1, ZL 99 8 14357.X, AUS 761094

IQ Switch®, ProxSense™, AirButton® and the IQ Logo are trademarks of Azoteq.

The information appearing in this application note is believed to be accurate at the time of publication. However, Azoteq assumes no responsibility arising from the use of the specifications described. The applications mentioned herein are used solely for the purpose of illustration and Azoteq makes no warranty or representation that such applications will be suitable without further modification, nor recommends the use of its products for application that may present a risk to human life due to malfunction or otherwise. Azoteq products are not authorized for use as critical components in life support devices or systems. No licenses to patents are granted, implicitly or otherwise, under any intellectual property rights. Azoteq reserves the right to alter its products without prior notification. For the most up-to-date information, please contact ProxSenseSupport@azoteq.com or refer to the website.

WWW.AZOTEQ.COM

ProxSenseSupport@azoteq.com