



---

## Application Note: AZD052

### Conducted Immunity of ProxSense Designs

---

#### Table of Contents

Introduction	1
Overview of IEC61000-4-6	2
Improving Conducted Noise Immunity	5
Testing Alternatives	8
Differential Mode Conducted Noise	9
Document History	11

## 1 Introduction:

ProxSense designs are often part of larger systems where cable lengths exceed more than a few centimetres. These cables may be mains supply conductors, for interfacing or for a host of other interconnections. With longer cables, a real risk exists that radiated interference with frequencies below 80MHz may couple into the system via the cables. However, to test for immunity to radiated interference at these lower RF frequencies through the use of illuminating antennas is not practical, due to the excessively large antenna sizes required. For example, at 30MHz, wavelength is 10m, so a half-wave dipole antenna would be 5m long!

To overcome the limit, the simplifying assumption may be made that radiated interference has coupled successfully into the cables of the system, and is flowing as interference currents between the coupling source and a low-potential point, typically a ground plane. To test for immunity against such conducted interference currents, one only requires a suitable signal generator and amplifier, along with the proper circuitry to couple the interference currents into the cables of the system under test.

The most common generic standard that describes testing for such conducted interferences in the 150kHz to 80MHz band is IEC 61000-4-6. In a certain sense this standard is just an extension of the radiated immunity standard IEC 61000-4-3 mentioned in application note AZD015. The conducted immunity standard allows for testing up to 230MHz, should the device under test and its cables have dimensions less than a quarter wavelength. The lower frequency of 150kHz may also be raised if the device is small enough. It is normally up to a specific product committee to decide what frequency band pertains. It should be noted that the interference signal here is of a continuous nature, with amplitude modulation, unlike that of the tests for immunity against surges or electrical fast transient bursts.

The above all refers to common mode noise, or currents that flow similarly in all conductors from a noise source to electrical earth. That is, for example, in a system with  $V_{CC}$  and Ground conductors, the noise currents are present in both conductors, and flow in the same direction towards an electrical earth entry point or area. Such common mode noise currents are especially detrimental to capacitive sensing systems given the coupling of electrodes with electrical earth, be it intentional, as with self-capacitance measurements, or unintentional, as with mutual capacitance measurements. Especially the lower frequencies of the band prescribed by IEC 61000-4-6 often coincide with typical charge transfer frequencies used and may cause either false annunciations of touch or proximity events or an inability to sense real events. Good PCB layout and the proper use of relevant common mode impedance can go a long way to improve common mode conducted immunity of ProxSense designs.



In the real world, however, ProxSense designs will not only be exposed to common mode conducted noise, as covered by IEC 61000-4-6. With the increasing prevalence of switch mode power supplies (SMPS) that switch in the high kHz to a few MHz range, the likelihood of a ProxSense design encountering differential mode conducted noise due to such a SMPS is increasing. Therefore, it is advisable to design for, and test against more than just IEC61000-4-6. Further, from EMC literature, it seems as if future editions of IEC61000-4-6 may address such differential mode noise as well, in which case present ProxSense designs will be future proofed if they exhibit immunity to differential mode noise.

This application note is intended to provide an overview of IEC61000-4-6, give some techniques and tips on improving the common mode conducted noise immunity of ProxSense designs, present some testing alternatives and lastly briefly discuss differential mode immunity.

## 2 Overview of IEC 61000-4-6:

The reader is advised to purchase a copy of the standard, as the present section merely serves as an introductory overview.

IEC61000-4-6 describes how one should go about to test for immunity against common mode conducted interference that has been induced into cables by radio-frequency fields from intentional **150kHz to 80MHz** transmitters. Systems that do not have a minimum of one cable to facilitate coupling of such interference are excluded from the standard.

Injection of the common mode interference may be done via three alternatives, according IEC 61000-4-6. The first is via the use of so-called **CDN's**, or couple-decouple networks. One may also use an Electromagnetic Clamp, which is what the name implies, and which is clamped around a specific cable. Or one may use what is known as Bulk Current Injection (BCI), which uses specific current clamps. One distinct difference between the standard and real world threats is the fact that interference only gets injected into one cable at a time if testing according to the standard. Of course, in the real world, radiated interference couples simultaneously to all the cabling of a given capacitive sensing application. Another gap in the standard is that the injected interference current is common mode only. This may be addressed in future editions of IEC 61000-4-6, as noted, since differential mode RF currents due to a SMPS or illuminating fields is quite possible.

Similarly to the requirement for radiated immunity testing, IEC 61000-4-6 requires that the applied noise signal be **amplitude modulated at 80%** depth, according to a **1kHz sine wave**. This is done to simulate modulation often present in signals emitted by broadcast transmitters.

In terms of the conducted interference level, things are not entirely unambiguous. The standard specifies levels of **1V**, **3V** and **10V**, all RMS values, for an open circuit. From these, the voltage over a 150Ω load that is connected to the ground reference plane can be found, and used for calibration. However, during test set-up and calibration to give one of these specific levels, it is done without above mentioned modulation. So the exact level while testing for immunity against conducted interference is not known, also since the impedance of the cables into a device is seldom 150Ω. For more information, please refer to IEC 61000-4-6. But in general, your ProxSense design should have **3V<sub>rms</sub> immunity**, which is the commercial product level.

According EMC literature, coupling of noise via a CDN seems to give the most repeatable and accurate results, therefore we will only discuss its usage. A couple-decouple network has three main functions. The first is to contain the injected noise only to the Device Under Test (DUT). In other words, it may be less than



desirable if you are trying to test your ProxSense design, but all you manage to do is reset your boss's PC, because you are also injecting noise into the local mains network. The second function is to stabilize the impedance of the noise source to  $150\Omega$ , i.e. to make sure that the noise source always have the same ability to provide noise currents. The third function is to prevent DC currents flowing between noise source and DUT and it's cabling. Figure 1 presents the general concept of CDN injection into a DUT with two AC power lines.

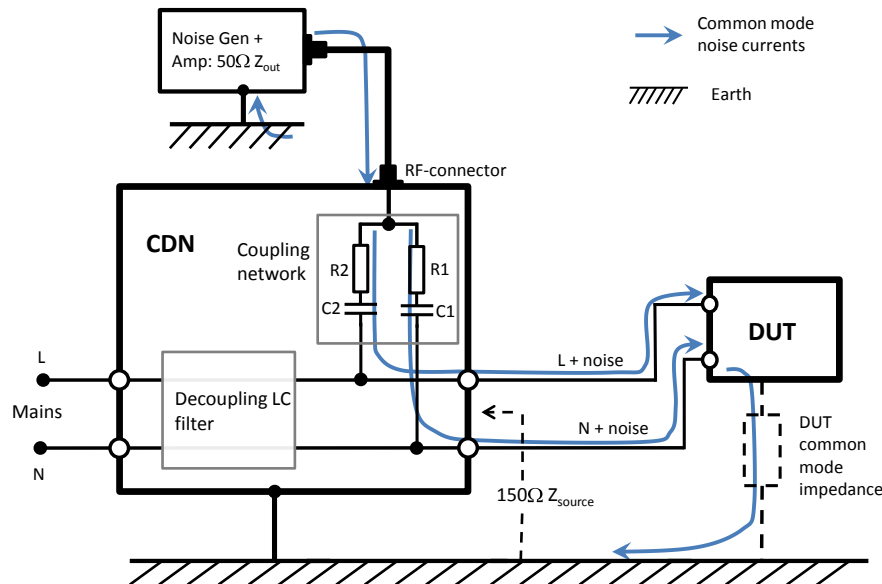

**Figure 1:** Injecting common mode noise into a DUT with two AC power lines, using a CDN.

As is evident from Fig. 1, the source impedance driving the noise currents are kept at  $150\Omega$ , as far as possible, according to IEC61000-4-6. Further, the common mode impedance of your ProxSense design provides the path back to the noise generator, and as such, its value and location may determine common mode noise immunity to a large extent. More about that later.

IEC61000-4-6 requires injection into all cables that are long enough to potentially pick-up RF radiation in the 150kHz – 80 MHz (or 230MHz, as noted earlier) band. Therefore, in general, any cable longer than 0.94m (1/4 wavelength @ 80MHz) should be tested. Each cable type require a specific CDN, please refer to IEC61000-4-6. For a large number of applications, the mains feeding cable is the longest, and therefore it is a natural point to start testing. However, in applications driven by isolated SMPS, a DC-voltage cable may also be quite long, for example for a laptop computer. Interpretation of IEC61000-4-6 may require that this cable also be tested, implying noise injection right at the DC-supply point of your ProxSense design. This presents a potentially far harder requirement to pass, dependent on the common mode impedance of the SMPS you use. Figure 2 illustrates the two cases.

From Fig.2, it becomes clear why DC-injection presents a potentially much harder requirement to pass. When injecting on the AC side, the SMPS may reflect or shunt a fair amount of the common mode noise energy, respectively through a high blocking impedance in both lines, or via a low impedance path to earth.

In terms of the test setup according to IEC61000-4-6, most ProxSense applications will be tested as table-top equipment. This means your product or device will be placed 100mm above a ground reference plane, which is connected to electrical earth, on top of a wooden table. The CDN must be within 0.1m to 0.3m of the DUT, and the ground plane should extend by at least 0.2m on all sides of the DUT.



**Injecting on AC side**

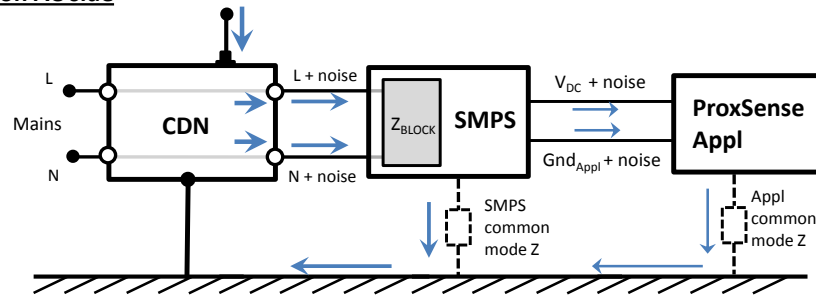

**Injecting on DC side**

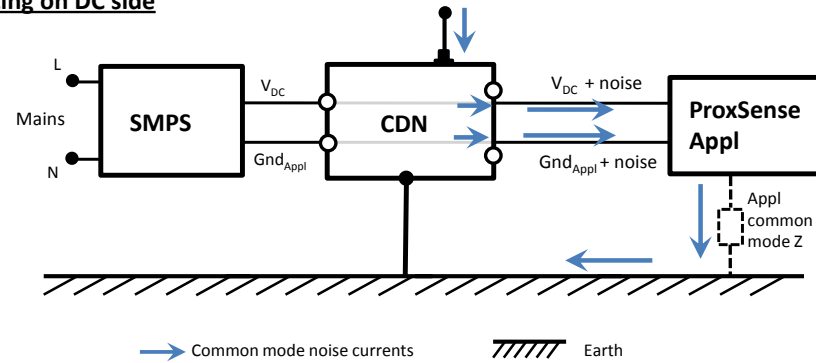

→ Common mode noise currents      Earth

**Figure 2:** Injecting noise on the AC or DC side of a ProxSense application

Once your product is powered via the CDN and is functional, the calibration data recorded to obtain the required test voltage over a 150Ω load is “played back”, with the frequency swept from 150kHz to 80MHz (or 230MHz, dependent on DUT size), a minimum dwell time of 0.5s and a maximum frequency change of 1% per step. That is, for each frequency, the signal generator is set to the value recorded during calibration that results in an amplifier output equivalent to the open circuit voltage specified by IEC 61000-4-6 (e.g. 3V<sub>rms</sub>). This setting is kept for at least 0.5s, after which the frequency is adjusted by no more than 1%, and the signal generator is set to the next corresponding amplitude point recorded.

Typically, a class A pass in terms of IEC 61000-4-6 requires no detriment in the functionality of the DUT. So for a ProxSense application, this implies no false touch or proximity event declarations, and the detection of all touch and proximity events. A class B pass allows some degradation, but requires the DUT to recover on its own, once the noise source is removed. So a design that blocks false touch or proximity event declarations due to noise being detected, but allow such events once the noise is gone, will achieve class B.

In terms of the amount of RF-power required to realize the mentioned commercial and industrial levels of 3V and 10V respectively, it seems that one needs at least 2 - 3W and 15 - 20W amplifiers. However, when over testing by 6dB, as is advisable to compensate for the difference in results from various test labs, the RF-power requirement becomes up to 12W and 60W respectively.

To conclude this overview of IEC61000-4-6, it must be said that it is a fairly complex standard, easily misapplied. For formal compliance testing, it is advised that a reputable, accredited EMC lab is used, and that the test method and results be scrutinized.

!! IEC61000-4-6 only applies to commercial products, not to Medical, Maritime, Avionics, Machinery and Automotive products where malfunction/failure could result in loss of life or large scale financial loss. Stringent international / local standards cover such applications.



!! Conducted immunity tests may involve hazardous voltages, also nominally in the DUT. Basic electrical safety principles should be applied. If unsure, consult a certified professional.

### 3 Improving Conducted Noise Immunity:

When considering common mode conducted noise, as per IEC 61000-4-6, it is evident that the immunity of ProxSense applications can be increased by minimizing the flow of noise currents via capacitive sensing electrodes. This may be achieved through a number of methods or techniques:

#### 3.1 Block the noise:

In general, conducted common mode noise will reach your ProxSense design via the power supply cable. It stands to reason that the inclusion of sufficient impedance in each wire of the cable will minimize the amount of noise currents that couple to earth via the capacitive sensing electrodes. Figure 3 illustrates the concept. Note that the impedance need to be frequency dependent, with a negligible DC / 50Hz value. Common mode chokes are mostly employed to realize such impedance. This technique may be applied to AC or DC supply lines. Take care when choosing a common choke as common mode impedance is normally strongly frequency dependent, with almost all chokes having a maximum impedance point, after which the parasitic winding capacitance starts to dominate, with a resulting decrease in impedance. Figure 4 presents the impedance of a typical surface mount common mode choke available commercially, and said point.

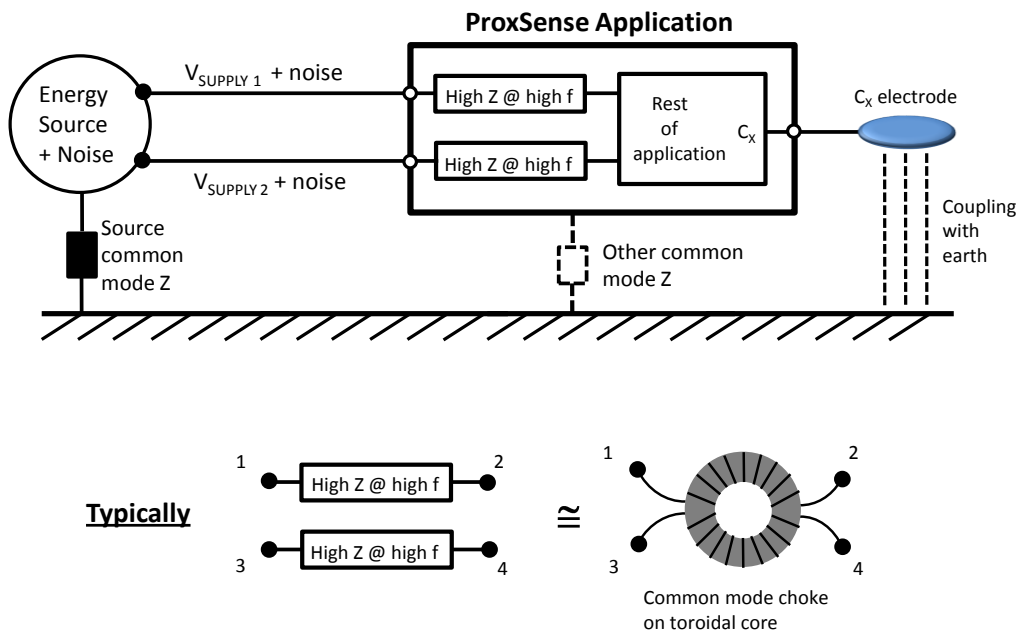
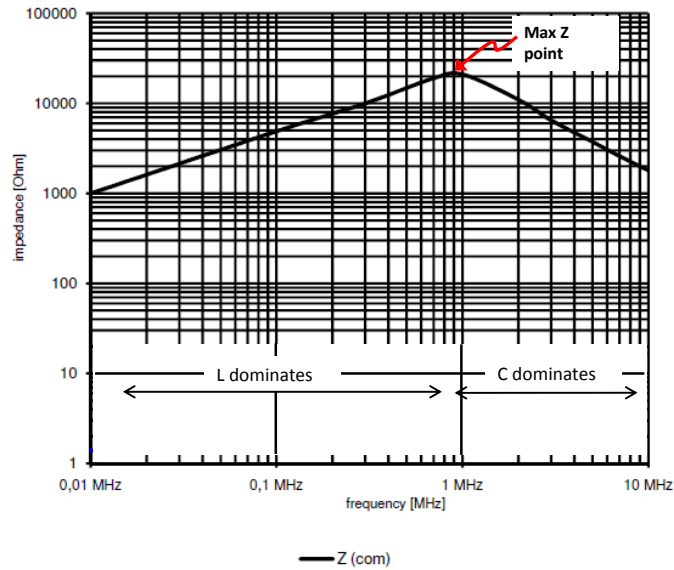

Figure 3: Blocking common mode noise currents with high impedance in each line



**Figure 4:** Common mode impedance of a typical SM common mode choke available commercially

### 3.2 Shunt the noise:

An alternative is to shunt noise currents to earth through a capacitance. Practically, this implies increasing the amount of copper area that can couple with the earth plane. (Connecting a discrete capacitor between your product and earth is not practical for most products, and also have safety implications in terms of earth leakage currents.) Note that as we are considering common mode noise, the increased copper area need not only be for the local ground. Any voltage rail may be used, be it Live, Neutral,  $V_{DC}$  or local ground. Figure 5 illustrates the concept of increasing the coupling to earth through additional copper.

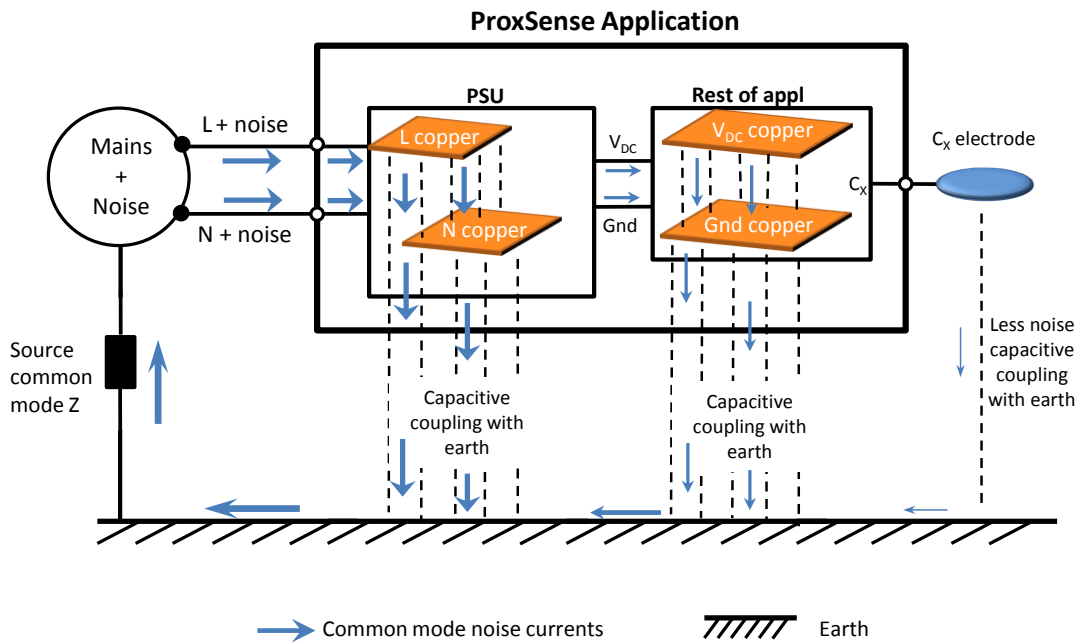

**Figure 5:** Shunting noise currents with additional copper to increase capacitive coupling with earth



The location of additional copper is also important. If common mode noise currents first encounter the copper of Cx electrodes, it would probably flow to earth via the electrodes, causing false touch and proximity event declarations. Experimentation have also shown that a ground ring around Cx electrodes works well to shunt noise currents away from the electrodes. Moreover, with the very high sensitivity realized by Azoteq capacitive sensing technology, it is possible to place ground directly beneath self-capacitance Cx electrodes (within 1 to 2mm), and still obtain very good touch detection, and proximity detection of around 10mm. Grounded copper beneath Cx electrodes significantly increases common mode noise immunity. Figures 6 and 7 present these concepts.

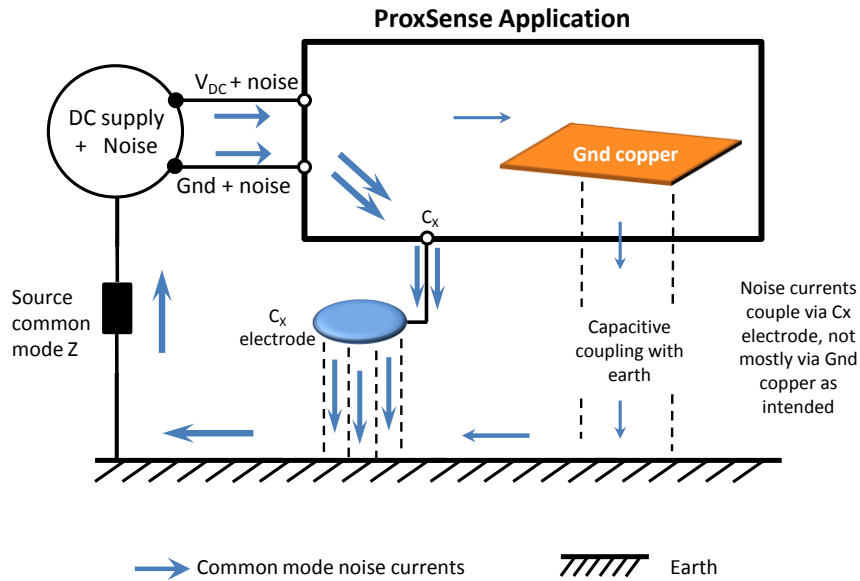

**Figure 6:** Physical location of additional copper is important

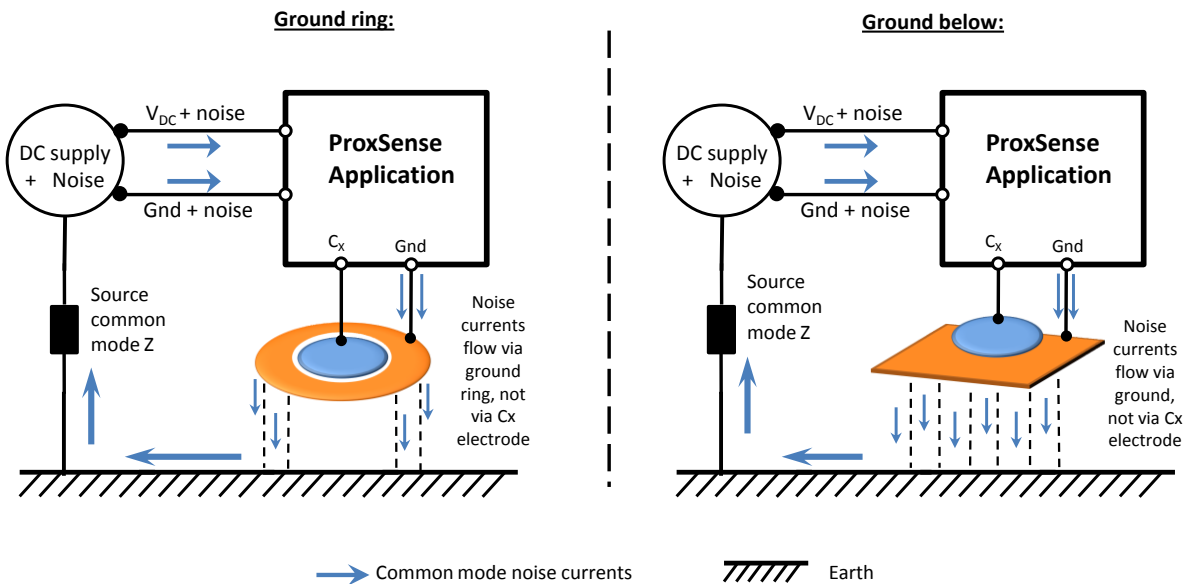

**Figure 7:** Use of a ground ring around and/or grounded copper below Cx electrodes to increase immunity





### 3.3 Selectively filter the noise:

Similarly to the transient currents of EFT events (see App note AZD051), common mode noise currents may cause differential voltage drops along the paths that they follow. Such differential voltage drops may result in failure mechanisms which may at first glance not seem related to common mode disturbances. Due to the high frequencies pertaining to conducted noise (150kHz – 80MHz/230MHz), it may be possible to use simple RC or LC low-pass filters to prevent failures due to such differential voltage drops. (refer to AZD015 for a discussion of simple filter use). Note that blind application of supply filters may not result in any increase in common mode conducted noise immunity, as noise currents flow in both supply lines in the same direction.

### 3.3 Burn the noise:

Another option is to use high resistance values ( on the order of 1k $\Omega$ ) in one or both the supply lines towards the IQSxxx device. This will result in noise energy being dissipated, rather than just being reflected back to source, which may result in re-incidence of the noise. Due to the extremely low operating currents of most IQS devices, typically well below 400 $\mu$ A, a 1k $\Omega$  resistor in the supply lines will cause a maximum drop of 0.4V. If such a voltage drop can be accommodated, for instance if the ProxSense application is standalone, and have no electronic communication to other devices, then burning the noise may be a viable option.

### 3.4 Recognise the noise:

Azoteq implements proprietary Anti Conducted Noise Mechanism (ACNM) technology, which allows the correct detection of touch and proximity events in the presence of conducted noise, and prevents false touch and proximity annunciations under such conditions. Further, if conducted noise is of an excessive nature, ACNM will block any changes in the logic state of output pins, preventing false annunciations, similar to Azoteq's RF-detection technology, aimed at UHF band noise (i.e. cell phone). Enquire for further details.

## 4 Testing alternatives:

Although the equipment required for proper pre-compliance IEC 61000-4-6 testing is not excessive by EMC standards (signal generator + 50W RF amp + CDN + spectrum analyser or similar), it may well be beyond the budget of most smaller companies. Therefore, below is a list of some alternative testing that may done to try and gauge the common mode conducted noise immunity of your design, without the high cost of a visit to an accredited EMC lab. Of course, for proper pre-compliance, and compliance measurements, you will still have to visit such a lab. The below alternatives would hopefully help to minimize the number of trips. Always try to validate your test against a product which has already been tested at an accredited facility. This may still lead to results from the alternative test which are grossly under or above what it required, but some testing is arguably better than no testing.

- Signal generator with basic capacitive clamp: Connect the output of the signal generator to two plates of the clamp, and place the supply leads that you want to couple to between the plates. Take care not to realize excessive capacitance, as this may damage your signal generator. (Calculate the capacitive reactance at the highest frequency of the test, it should not be too small...) The one plate of the clamp should be tied with a minimum inductance interconnect to your DUT ground, to allow noise currents to flow back to the signal generator. Also take care to isolate the plates of the clamp.
- Signal generator directly into local ground: It is possible to obtain useful, qualitative, but repeatable results by injecting noise directly into the local ProxSense ground with a signal generator, using a





50Ω -100Ω resistor to limit current. The ProxSense DUT is placed 0.1m above a ground reference plane connected to the signal generator ground. In a certain sense, this test simulates one part of IEC 61000-4-6, as it results in capacitive noise currents coupling with the ground reference plane via the copper of the local ProxSense ground.

- Direct injection: If the local ground of a ProxSense device is connected to the ground of an RF-source, and a suitable DC-blocking capacitor is connected in series with the RF-source output, the unconnected terminal of said capacitor may be used as a pin probe to inject RF-currents directly into various conductors of the ProxSense circuit. Even the limited output of a signal generator may result in very high RF-current levels. **Please note that direct injection is a risky test**, both for your DUT, and for your RF-source, and other equipment nearby. If an amplifier is used in conjunction with the signal generator, a current limiting resistor must be used. When injecting into mains cables, ensure that the series capacitor mentioned above is a high voltage Class Y rated device. Mains injection will also result in current surges through the series capacitor as contact is made, which may damage your RF-source. **Do not pursue this alternative method if you are unsure, and follow relevant safety procedures when working with high voltages.** On the other hand, it allows severe testing of designs without too much effort or cost.

**!! In all the above, care must be taken not to exceed local legal limits for RF-radiation. Severe consequences, some fatal, can result if limits are exceeded. If unsure, consult an EMC specialist.**

## 5 Differential Mode Conducted Noise:

As noted, real life conducted noise is not limited to common mode only, but may often be differential mode in nature. Figure 8 illustrates the difference between the two modes. Typical sources of differential mode noise are SMPS, arcing contacts (which may also result in common mode noise – EFT), LCD screen drivers etc. In a certain sense, because differential conducted noise is based on a voltage difference between two conductors present in a circuit, for example  $V_{DD}$  and Gnd, it is easier to filter. We advise the following to improve the immunity of ProxSense applications to differential mode conducted noise:

- Use single or two stage RC or LC filters on supply lines, especially from SMPS – see AZD015 for further details on basic filters.
- Be wary of very low cost SMPS. A number of higher quality SMPS employ controllers that use some dithering on the main switching frequency to limit emissions.
- Follow Radiated Immunity PCB guidelines, as described in AZD015, to minimize detrimental effects. Especially proper decoupling of Vdd and Gnd through realization of sufficient copper on opposing layers, where possible, may improve differential mode immunity.
- Take care when routing supply or capacitive sensing lines close to SMPS sections, or underneath LCD screens.

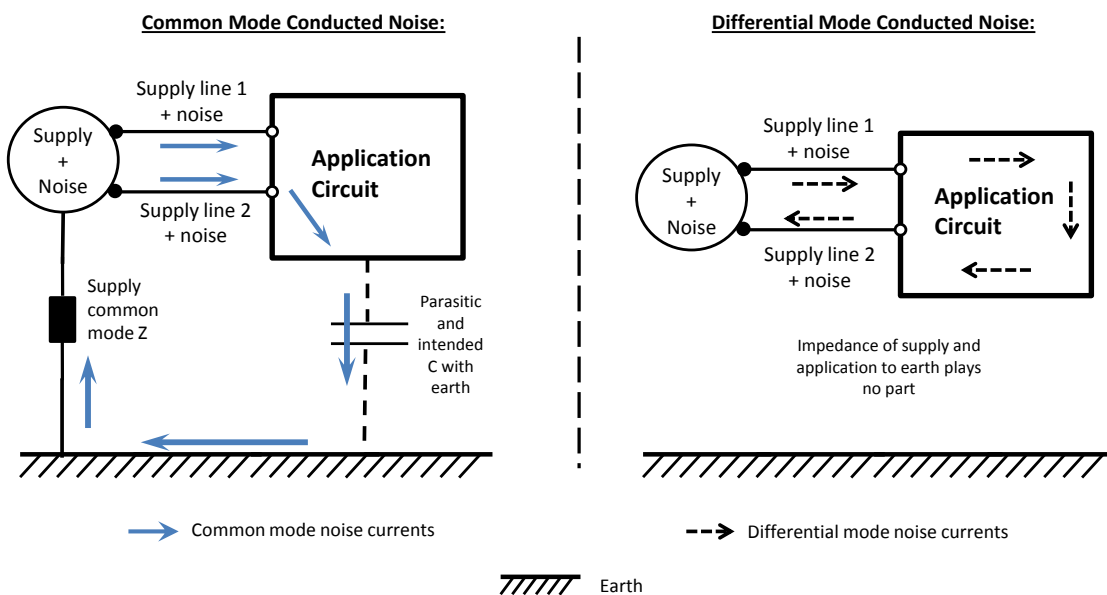

**Figure 8:** Common mode and differential mode conducted noise currents

## 6 Document History

v1.0, April 2012	J.D. van Wyk, Sr. Application & Development Engineer	Creation

The following patents relate to the device or usage of the device: US 6,249,089 B1, US 6,621,225 B2, US 6,650,066 B2, US 6,952,084 B2, US 6,984,900 B1, US 7,084,526 B2, US 7,084,531 B2, US 7,119,459 B2, US 7,265,494 B2, US 7,291,940 B2, US 7,329,970 B2, US 7,336,037 B2, US 7,443,101 B2, US 7,466,040 B2, US 7,498,749 B2, US 7,528,508 B2, US 7,755,219 B2, US 7,772,781, US 7,781,980 B2, US 7,915,765 B2, EP 1 120 018 B1, EP 1 206 168 B1, EP 1 308 913 B1, EP 1 530 178 B1, ZL 99 8 14357.X, AUS 761094

IQ Switch®, ProxSense®, LightSense™, AirButton® and the  logo are trademarks of Azoteq.

The information in this Datasheet is believed to be accurate at the time of publication. Azoteq assumes no liability arising from the use of the information or the product. The applications mentioned herein are used solely for the purpose of illustration and Azoteq makes no warranty or representation that such applications will be suitable without further modification, nor recommends the use of its products for application that may present a risk to human life due to malfunction or otherwise. Azoteq products are not authorized for use as critical components in life support devices or systems. No licenses to patents are granted, implicitly or otherwise, under any intellectual property rights. Azoteq reserves the right to alter its products without prior notification. For the most up-to-date information, please refer to [www.azoteq.com](http://www.azoteq.com).

[WWW.AZOTEQ.COM](http://WWW.AZOTEQ.COM)

[ProxSenseSupport@azoteq.com](mailto:ProxSenseSupport@azoteq.com)