



---

# Application note: AZD036

## Mutual Capacitance Button Layout Guideline

---

### Contents

<b>APPLICATION NOTE: AZD036</b> .....	<b>1</b>
<b>1 MUTUAL CAPACITANCE</b> .....	<b>2</b>
1.1 INTRODUCTION.....	2
<b>2 EXAMPLE BUTTON LAYOUTS</b> .....	<b>2</b>
FIGURE 2.1 EXAMPLE BUTTON 1.....	2
FIGURE 2.2 EXAMPLE BUTTON 2.....	2
FIGURE 2.3 EXAMPLE BUTTON 3.....	3
FIGURE 2.4 EXAMPLE BUTTON 5.....	3
FIGURE 2.5 EXAMPLE BUTTON 4.....	3
FIGURE 2.6 EXAMPLE BUTTON 6.....	3
<b>3 BUTTON APPLICATION</b> .....	<b>4</b>
3.1 NOISE IMMUNITY.....	4
FIGURE 3.1 EXAMPLE ROUTING OF EXAMPLE BUTTON 6.....	4
<b>4 LAYOUT GUIDELINES</b> .....	<b>5</b>
FIGURE 4.1 SHIELDING USING GROUND.....	5
FIGURE 4.2 RIGHT ANGLE CROSSING.....	5
FIGURE 4.3 GROUND PLANE DISTANCE FOR PROXIMITY APPLICATIONS.....	5
<b>5 DETAILED DISCUSSION</b> .....	<b>6</b>
5.1 INTRODUCTION.....	6
5.2 DEFINITIONS.....	6
5.2.1 <i>Mutual Capacitance</i> .....	6
5.2.2 <i>Sensitivity</i> .....	6
5.2.3 <i>Noise</i> .....	6
5.2.4 <i>Proximity Distance</i> .....	6
5.2.5 <i>Parasitic Capacitance</i> .....	6
5.3 SENSITIVITY.....	6
5.4 PARASITIC CAPACITANCE.....	7
5.5 GROUND LOADING.....	7
5.6 PROXIMITY DISTANCE.....	7
5.7 WATER EFFECTS.....	7
5.8 LAYOUT CONSIDERATIONS.....	7
5.8.1 <i>Electrode Thickness and Placement</i> .....	7
5.8.2 <i>Noise</i> .....	8
5.8.3 <i>Floating Conductors</i> .....	8
5.8.4 <i>LEDs</i> .....	8
<b>6 CONTACT INFORMATION</b> .....	<b>9</b>



# 1 Mutual Capacitance

## 1.1 Introduction

Projected capacitance technology measures the change in capacitive coupling between two electrodes. The coupling between the electrodes is called “Mutual capacitance” /  $C_M$  and the electrodes are called the transmitter (CTx or just Tx) and receiver (CRx or just Rx). See application note AZD008 for more details on the differences between self-capacitance and projected capacitance technologies. In addition, how to relate the measured capacitance to charge transfers.

Projected capacitance can yield a higher resolution response to touch and proximity events because the electrode size, shape and spacing can be controlled by the designer and the buttons are less dependent on the ground

(earth) reference in battery applications. Projected capacitance also requires fewer pins when applied to multi-channel IC solutions because buttons are multiplexed between pins.

## 2 Example Button Layouts

Six possible layouts are shown in this section. The application of each will be discussed in Section 3. The first example is recommended as starting point for new designers' applications. Drawing files for all the designs are available from [info@azoteq.com](mailto:info@azoteq.com).

Note that all dimensions are in millimetres and that “Tx” represents the transmit electrode while “Rx” represents the receive electrode.

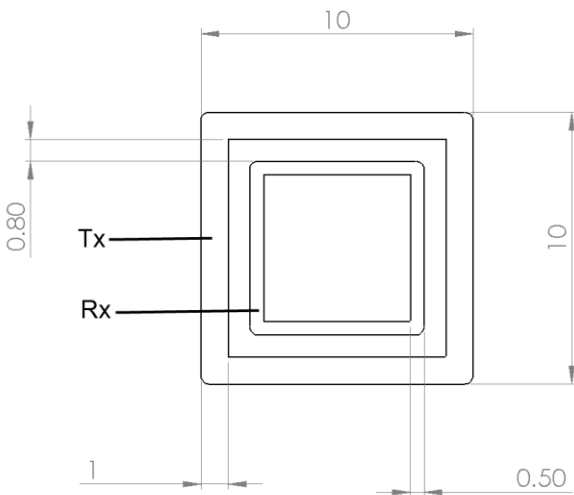

Figure 2.1 Example Button 1

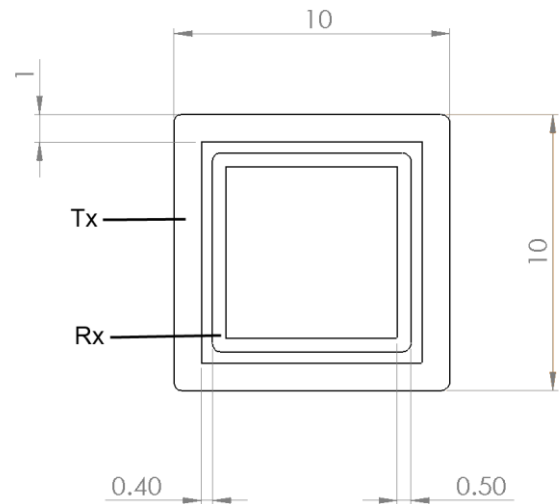
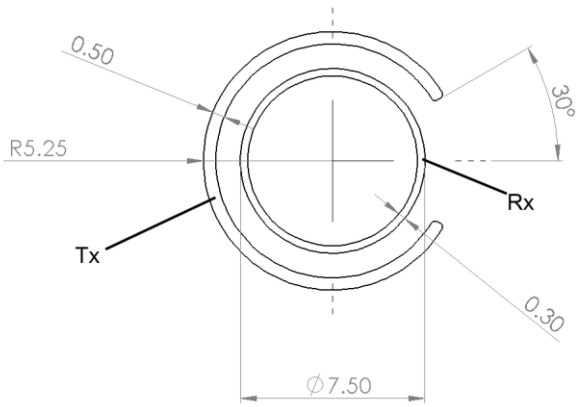
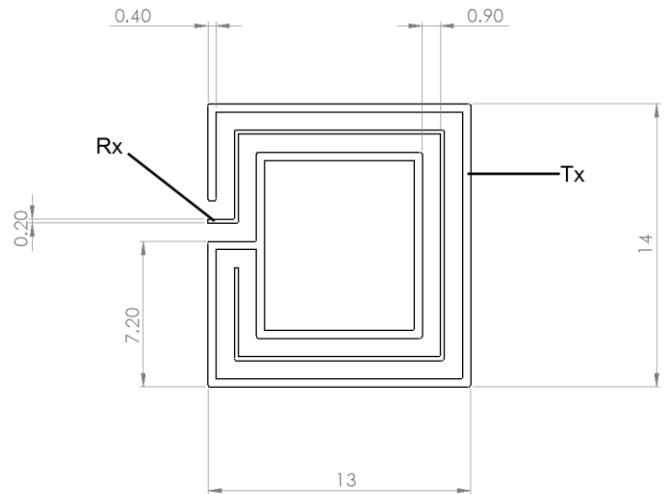

Figure 2.2 Example Button 2.



**Figure 2.3 Example Button 3.**



**Figure 2.5 Example Button 4.**

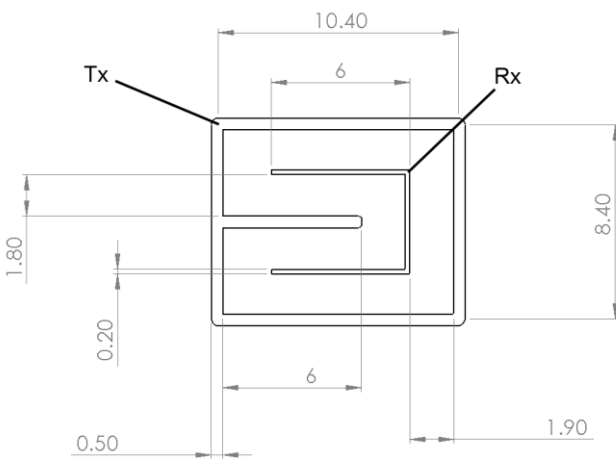

**Figure 2.4 Example Button 5.**

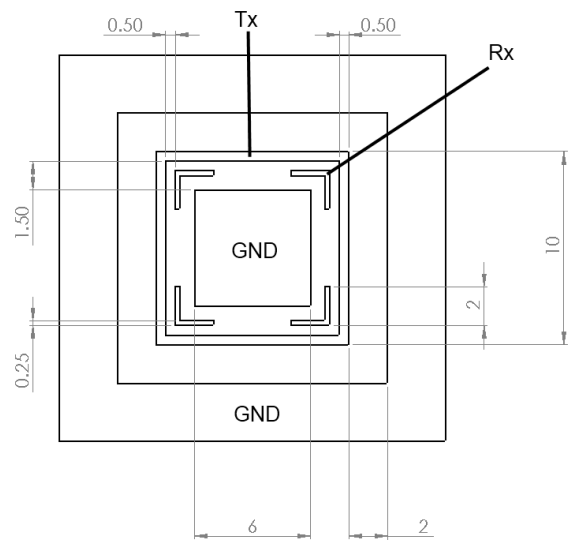

**Figure 2.6 Example Button 6.**



### 3 Button Application

This section displays which button layout can be used for different applications. More ticks indicate a more suitable solution.

	Proximity	Touch	2mm Overlay	5mm Overlay	LEDs	Water Detect	Water Immunity
Layout 1	√√√	√√	√√√	√√√	√√√	√√	√
Layout 2	√√	√√√	√√√	√√	√√√	√√	√√
Layout 3	√	√√	√√	√	√√√	√	√√
Layout 4	√√	√√	√√	√	√√√	√	√√√
Layout 5	√	√√	√√	√√	√√√	√	√√√
Layout 6	√	√√√	√√√	√√	√√√	√	√√√

#### 3.1 Noise Immunity

Example button 6 is recommended for the most robust solution for noise immunity.

An example for PCB layout and routing is shown below. Rx lines are routed on the bottom layer and shielded with GND on the top

layer. For added noise immunity a GND pour layer is recommended on the bottom layer as well. Depending on the application requirement, it could be solid or hatched pour with stitching vias up to 3mm apart. It is recommended to have a maximum fill of 30% in the GND pour directly below the button.

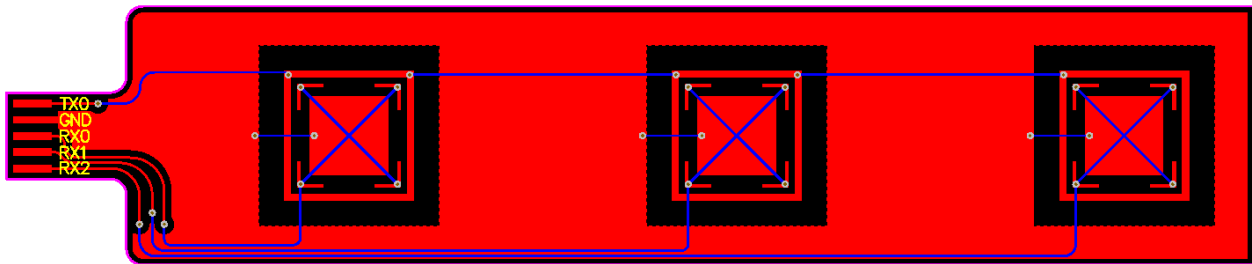
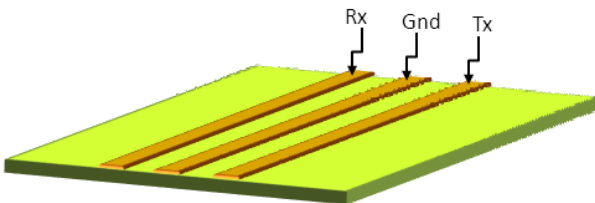

Figure 3.1 Example routing of example button 6.

## 4 Layout Guidelines

A few simple considerations for the layout of projected buttons on printed circuit boards will be discussed below. Throughout this section “**Tx**” denotes the transmitting electrodes while “**Rx**” denotes the receiving electrodes. For a more in-depth discussion of the guidelines below, see Section 5.

- Generally the Rx track should be routed as far away as possible from the Tx track.
- Where design limitations require the Rx and Tx tracks to run close to each other in parallel a ground track should be routed between them for shielding purposes as shown in Figure 4.1.



**Figure 4.1** Shielding using ground.

- If a **Rx** and **Tx** track has to cross on a multilayer PCB the crossing should always be done at a 90° angle (Right Angles). This is demonstrated in Figure 4.2. Care should be taken for thinner PCBs such as FPC, to reduce the area of Tx and Rx crossing over each other to the absolute minimum.

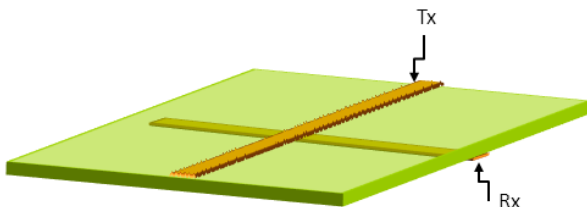

**Figure 4.2** Right Angle Crossing.

The **Rx** and **Tx** tracks should be routed far away from any communications, LED, or any other digital tracks. If this is not possible a ground track should be routed between the button track and the digital track.

To ensure optimal button sensitivity for proximity applications it is suggested that ground layers should be placed as far as possible away from the projected button, suggested distance is 10mm. For touch applications a gap of 1 mm would be sufficient. For proximity application less ground in the button area will ensure better detection distance. Figure 4.3 illustrates this principle.

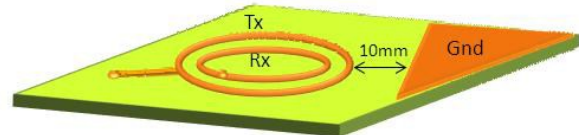

**Figure 4.3** Ground Plane Distance for proximity applications.

- Ground tracks in the vicinity of the touch button should be kept as thin and as short as possible.
- For applications where substantial ground planes will be present near the **Rx** and **Tx** tracks it is suggested that a button layout is chosen where the coupling between **Rx** and **Tx** is maximized. Layout 5 (Figure 2.4) from the button examples would fit this description.
- No **floating** tracks or conductive materials should be placed close to the touch buttons or the **Tx** and **Rx** tracks.



## 5 Detailed Discussion

### 5.1 Introduction

This section gives general guidelines for the design of robust touch buttons using the projected capacitive sensing technique. The button designs will be evaluated in terms of several parameters which include:

- Sensitivity
- Noise Immunity (Non RF Noise)
- Proximity Distance
- Water Effects

The difference in button design for the use with battery application will not be discussed.

This information does not take into account the sensitivity variations possible using automated sensitivity tuning algorithms.

### 5.2 Definitions

The terms used throughout this section will be briefly discussed in this section.

#### 5.2.1 Mutual Capacitance

Mutual capacitance is the measured quantity of projected capacitive sensing. This equates to the capacitance between transmit and receive electrode as well as any other unwanted coupling (parasitic capacitance and noise).

#### 5.2.2 Sensitivity

In terms of this document sensitivity is defined as the deviation in capacitance caused by a user's hand for proximity or touch purposes. This only includes the "wanted" deviation caused by the user and not the unwanted deviation induced due to noise.

#### 5.2.3 Noise

In contrast to sensitivity noise is defined as the unwanted deviation in mutual capacitance due to various external and internal factors.

#### 5.2.4 Proximity Distance

The distance from the overlay where a user's hand will be detected before touching the electrode overlay will be defined as the proximity distance. This figure is generally correlated to the noise for the minimization of false proximity detections.

### 5.2.5 Parasitic Capacitance

This is any mutual capacitance between the transmitter and receiver electrodes that the user is unable to influence or that the user is able to unintentionally influence. An example would be the capacitance caused due to transmit and receive tracks being close to each other outside the button area.

### 5.3 Sensitivity

The sensitivity of a projected touch button is correlated to the amount of nominal capacitance of the button area between the transmitter and receiver electrodes. Nominal, in this sense, is the button capacitance without any external influence. It is important to remember that only the capacitance of the button area should be influenced by the user.

**Generally speaking, closely coupled transmit and receive electrodes (high mutual capacitance) will result in a less sensitive button than would a button with loose coupling.**

This in turn limits the type and thickness of the overlay that can be used with a certain button design. A thick overlay using a material with a low relative dielectric constant will thus need a low mutual capacitance for correct button operation. This makes intuitive sense since the user will have less influence on the mutual capacitance and if this capacitance is relatively large almost no deviation will be detectable.

It is important to note the available options for lowering the mutual capacitance:

$$C = \epsilon_r \epsilon_0 \frac{A}{d}$$

- The type of dielectric material can be changed. This is true for the inter-electrode material (i.e. FR4 for printed circuit board designs) as well as for the overlay. Note that an overlay with a good dielectric constant will increase the capacitance but will also increase the deviation caused by a touch as this will also increase the capacitive coupling between the user's hand and the button electrodes.
- The distance between the transmit electrode and receive electrode can be



increased to lower the mutual capacitance.

- The area or length of the transmit and receive electrodes in relation to each other can also be varied.

## 5.4 Parasitic Capacitance

The mutual capacitance increases wherever the transmit and receive tracks are in close proximity to each other. This is also true for the PCB tracks connecting the transmit and receive electrodes to the sensing IC.

This capacitance should not be influenced by the user and thus must be kept to a minimum. A fixed amount of capacitance has thus been added to your system that cannot be influenced by the user. Parasitic capacitance lowers your button sensitivity.

It is thus good practice to shield the transmit and receive tracks from each other using a ground track. Furthermore any crossing of the Transmit and Receive tracks should be done at a 90° angle.

## 5.5 Ground Loading

The designer should also keep coupling from the electrodes to ground to a minimum. This is especially true of the receive electrode. The most substantial effect will be noticeable in proximity applications where the proximity distance lowers with any close ground planes or tracks. For button (touch) applications this is less of a problem as long as the designer also notes that close ground tracks will lower the mutual capacitance whilst not necessarily increasing button sensitivity.

## 5.6 Proximity Distance

In order to facilitate a large proximity distance, loose coupling between the transmit and receive electrodes are necessary. Generally speaking, the larger the distance between the transmit and receive electrode, the larger the detectable proximity distance.

Influences that will lower the detectable proximity distance are as follows:

- Ground planes or tracks near the electrodes will decrease the proximity distance.
- A large parasitic capacitance will minimize

the deviation caused by the user and thus also decrease the proximity distance.

## 5.7 Water Effects

In applications where water might be present on the touchpad overlay, care should be taken to use the correct button layout.

Buttons having a relatively high mutual capacitance tend to have high water immunity. Water directly on the button overlay will thus not cause false touch detection. Note that due to the sensitivity of the sensing IC, false proximity detections might still be possible.

Buttons having a very low mutual capacitance offers another solution for water effects. Due to the measuring sensitivity water will easily be detectable as a substantial increase in mutual capacitance. This is in contrast to a human touch which has the effect of lowering the mutual capacitance. Water on these buttons will thus not cause a false touch detection but will easily be detectable offering the designer an opportunity to guard against incorrect application operation.

Note that overlays having a high relative dielectric constant will increase the effects of water on the mutual capacitance.

It is also important to notice that due to the conductive properties of water touching any water drops on the overlay will effectively expand the area of the finger to that of the size of the water drop. If a large amount of water is present directly over two adjacent buttons touching the water will cause both buttons to detect touch conditions. It is recommended that the application guard against two buttons being pressed simultaneously in order to mitigate this situation.

## 5.8 Layout Considerations

This section discusses a few considerations for PCB layout while using projected capacitance for touch buttons.

### 5.8.1 Electrode Thickness and Placement

In order to increase the noise immunity of the button electrodes it is recommended that the receive electrode be made as thin as possible. This will decrease the ground loading of the



receive electrode as well as minimizing any external noise coupling.

It is also generally recommended that the transmit electrode completely surrounds the receive electrode. This will ensure that the receive electrode will be relatively shielded from external influences. Transmit electrodes should also generally be thicker than receive electrodes to improve this shielding effect. In applications where a large proximity is desirable it might not be possible to incorporate these suggestions as this will decrease the proximity sensing sensitivity.

### 5.8.2 Noise

It is advantageous to route any digital communication lines as far from the sensing electrodes and tracks as possible. Where this is not possible it is necessary to run a ground track between the communication lines and the sensing lines for shielding purposes.

### 5.8.3 Floating Conductors

The designer should refrain from placing any floating conductors near the sensing electrodes or sensing tracks. This includes floating tracks. Any floating conductor close to the sensing lines will act as a transmit electrode causing noise and unreliable operation.

### 5.8.4 LEDs

Light emitting diodes tend to have very little effect on projected button operation. It is suggested that all the tracks connected to the LEDs should not be floating for reasons discussed earlier. It is recommended to add a 10nF capacitor from the floating point of the LED driving circuit to GND. For more details see AZD008.





## 6 Contact Information

	<b>USA</b>	<b>Asia</b>	<b>South Africa</b>
<b>Physical Address</b>	6507 Jester Blvd Bldg 5, suite 510G Austin TX 78750 USA	Rm1725, Glittery City Shennan Rd Futian District Shenzhen, 518033 China	109 Main Street Paarl 7646 South Africa
<b>Postal Address</b>	6507 Jester Blvd Bldg 5, suite 510G Austin TX 78750 USA	Rm1725, Glittery City Shennan Rd Futian District Shenzhen, 518033 China	PO Box 3534 Paarl 7620 South Africa
<b>Tel</b>	+1 512 538 1995	+86 755 8303 5294 ext 808	+27 21 863 0033
<b>Fax</b>	+1 512 672 8442		+27 21 863 1512
<b>Email</b>	kobusm@azoteq.com	linayu@azoteq.com.cn	info@azoteq.com

Please visit [www.azoteq.com](http://www.azoteq.com) for a list of distributors and worldwide representation.

The following patents relate to the device or usage of the device: US 6,249,089 B1, US 6,952,084 B2, US 6,984,900 B1, US 7,084,526 B2, US 7,084,531 B2, EP 1 120 018 B2, EP 1 206 168 B1, EP 1 308 913 B1, EP 1 530 178 A1, ZL 99 8 14357.X, AUS 761094, HK 104 14100A, US13/644,558, US13/873,418

IQ Switch®, SwipeSwitch™, ProxSense®, LightSense™, AirButton® and the  logo are trademarks of Azoteq.

The information in this Datasheet is believed to be accurate at the time of publication. Azoteq uses reasonable effort to maintain the information up-to-date and accurate, but does not warrant the accuracy, completeness or reliability of the information contained herein. All content and information are provided on a "as is" basis only, without any representations or warranties, express or implied, of any kind, including representations about the suitability of these products or information for any purpose. Azoteq disclaims all warranties and conditions with regard to these products and information, including but not limited to all implied warranties and conditions of merchantability, fitness for a particular purpose, title and non-infringement of any third party intellectual property rights. Azoteq assumes no liability for any damages or injury arising from any use of the information or the product or caused by, without limitation, failure of performance, error, omission, interruption, defect, delay in operation or transmission, even if Azoteq has been advised of the possibility of such damages. The applications mentioned herein are used solely for the purpose of illustration and Azoteq makes no warranty or representation that such applications will be suitable without further modification, nor recommends the use of its products for application that may present a risk to human life due to malfunction or otherwise. Azoteq products are not authorized for use as critical components in life support devices or systems. No licenses to patents are granted, implicitly, express or implied, by estoppel or otherwise, under any intellectual property rights. In the event that any of the abovementioned limitations or exclusions does not apply, it is agreed that Azoteq's total liability for all losses, damages and causes of action (in contract, tort (including without limitation, negligence) or otherwise) will not exceed the amount already paid by the customer for the products. Azoteq reserves the right to alter its products, to make corrections, deletions, modifications, enhancements, improvements and other changes to the content and information, its products, programs and services at any time or to move or discontinue any contents, products, programs or services without prior notification. For the most up-to-date information and binding Terms and Conditions please refer to [www.azoteq.com](http://www.azoteq.com).

[WWW.AZOTEQ.COM](http://WWW.AZOTEQ.COM)

[info@azoteq.com](mailto:info@azoteq.com)